

TECHNICAL MANUAL

OPERATORS, ORGANIZATIONAL,  
DIRECT SUPPORT AND  
GENERAL SUPPORT MAINTENANCE

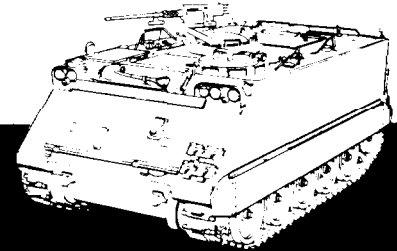

**BATTLEFIELD DAMAGE  
ASSESSMENT AND REPAIR**

FOR  
M113 FAMILY  
CARRIER, PERSONNEL  
SELF-PROPELLED  
FULL-TRACKED

ITEM NSN  
INSIDE FRONT COVER

CHAPTER 1	INTRODUCTION
CHAPTER 2	ASSESSING BATTLEFIELD DAMAGE
CHAPTER 3	ENGINE
CHAPTER 4	FUEL SUPPLY SYSTEM
CHAPTER 5	COOLING SYSTEM
CHAPTER 6	ELECTRICAL SYSTEM
CHAPTER 7	POWERTRAIN / STEERING
CHAPTER 8	TRACK AND SUSPENSION
CHAPTER 9	HYDRAULIC SYSTEM
CHAPTER 10	ARMOR
CHAPTER 11	COMMUNICATION SYSTEMS
APPENDIX A	ALTERNATE SOURCES OF SUPPLY
APPENDIX B	SPECIAL AND FABRICATED TOOLS
APPENDIX C	POL SUBSTITUTES

**BDAR FIXES SHALL BE USED ONLY IN COMBAT  
AT THE DISCRETION OF THE COMMANDER  
AND SHALL BE REPAIRED BY STANDARD MAINTENANCE PROCEDURES  
AS SOON AS PRACTICABLE AFTER THE MISSION IS COMPLETED.**

**BDAR TECHNIQUES IN THIS MANUAL PERTAIN to the following full tracked, self propelled M113 family of vehicles:**

<b>M113A1</b>	Carrier, Personnel Armored	<b>NSN 2350-00-968-6321</b>
<b>M113A2</b>	Carrier, Personnel Armored	<b>NSN 2350-00-068-4077</b>
<b>M577A1</b>	Carrier, Command Post, Light	<b>NSN 2350-00-056-6808</b>
<b>M577A2</b>	Carrier, Command Post, Light	<b>NSN 2350-00-068-4089</b>
<b>M106A1</b>	Carrier, Mortar, 107MM	<b>NSN 2350-00-076-9002</b>
<b>M106A2</b>	Carrier, Mortar, 107MM	<b>NSN 2350-01-069-6931</b>
<b>M125A1</b>	Carrier, Mortar, 81MM	<b>NSN 2350-01-071-0732</b>
<b>M125A2</b>	Carrier, Mortar, 81MM	<b>NSN 2350-01-068-4087</b>
<b>M741</b>	Chassis, AAA, 20MM	<b>NSN 2350-00-115-4418</b>
<b>M741A1</b>	Chassis, AAA, 20MM	<b>NSN 2350-01-099-8929</b>
<b>M548</b>	Carrier, Cargo, 6 Ton	<b>NSN 2350-00-078-4545</b>
<b>M548A1</b>	Carrier, Cargo, 6 Ton	<b>NSN 2350-01-096-9356</b>
<b>M730</b>	Carrier, Guided Missile	<b>NSN 1450-00-930-8749</b>
<b>M730A1</b>	Carrier, Guided Missile	<b>NSN 1450-00-121-2122</b>
<b>M667</b>	Carrier, Guided Missile Equipment	<b>NSN 1450-00-879-3380</b>
<b>M901</b>	Combat Vehicle, Anti Tank, ITV	<b>NSN 2350-01-045-1123</b>
<b>XM806E1</b>	Recovery Vehicle, Light Armored	<b>NSN 2350-00-808-6104</b>

CHANGE

NO. 1

HEADQUARTERS  
DEPARTMENT OF THE ARMY  
Washington D. C., 30 November 1990

**TECHNICAL MANUAL**  
**OPERATORS, ORGANIZATIONAL**  
**DIRECT SUPPORT AND**  
**GENERAL SUPPORT MAINTENANCE**  
BATTLEFIELD DAMAGE  
ASSESSMENT AND REPAIR  
for  
M113 FAMILY  
CARRIER, PERSONNEL  
SELF-PROPELLED  
FULL-TRACKED

TM 9-2350-275-BD, 9 February 1984 is changed as follows:

1. Remove old pages and insert new pages as indicated below.
2. New or changed material is indicated by a vertical bar in the margin of the page.

Remove Pages	Insert Pages
None	D-1 and D-2 (D-2 blank)
None	E-1 and E-2

File this change sheet in front of the publication for reference purposes.

By Order of the Secretary of the Army

CARL E. VUONO  
*General, United States Army*  
*Chief of Staff*

THOMAS F. SIKORA  
*Brigadier General, United States Army*  
The Adjutant General

Distribution:

To be distributed IAW DA Form 12-37-E, (Block No. 1687) Operator, Unit and Direct Support and General Support maintenance requirements for TM 9-2350-275-BD.

**Approved for Public release; distribution is unlimited.**

WARNING

THIS TECHNICAL MANUAL CONTAINS NON-STANDARD MAINTENANCE PROCEDURES. ALL NORMAL SAFETY PROCEDURES SHOULD BE OBSERVED WHEN THE TACTICAL SITUATION PERMITS. EXTRA CARE WILL BE TAKEN WHEN THE TACTICAL SITUATION REQUIRES PERFORMING MAINTENANCE WITH AMMUNITION UP-LOADED AND WHEN FUELS AND LUBRICANTS ARE SPILLED IN HULL AND TURRET.

**WARNING**  
**RADIOACTIVE MATERIAL**

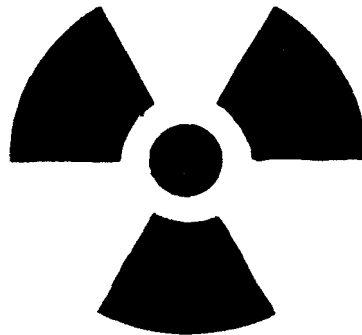

---

WARNING

The antireflective coating on all infrared optics contains thorium fluoride which is slightly radioactive. The only potential hazard involves ingestion (swallowing or inhaling) of this material. Dispose of broken lens, etc. in accordance with AR 385-11.



WARNING

You can be blinded if you look into a laser beam when you are not wearing laser safety goggles. Never arm the laser rangefinder (LRF) at personnel.

If laser beam reflects from a flat, mirror-like surface, it can blind you unless you are wearing laser safety goggles.

**WARNING**

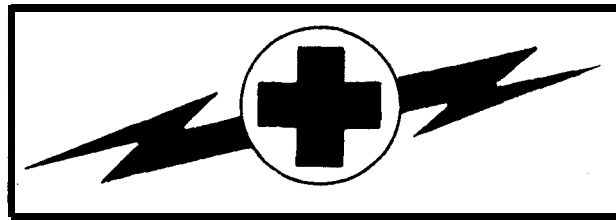

HIGH VOLTAGE

High voltage is used in the operation of this equipment.

**DEATH ON CONTACT**

may result if personnel fail to observe safety precautions. Learn the areas containing high voltage in each piece of equipment. Be careful not to contact high voltage connections when installing or operating this equipment. Before working inside the equipment, turn power off and ground points of high potential before touching them.

For artificial respiration, refer to FM 21-11.

**OPERATOR'S, ORGANIZATIONAL  
DIRECT SUPPORT AND GENERAL SUPPORT  
MAINTENANCE**

**BATTLEFIELD DAMAGE  
ASSESSMENT AND REPAIR  
for  
M 113 FAMILY OF VEHICLES**

**REPORTING OF ERRORS**

You can help to improve this manual by calling attention to errors and by recommending improvements. Your letter, DA Form 2028 (Recommended Changes to Publications and Blank Forms) and/or DA Form 2028-2 (Recommended Changes to Equipment Technical Manuals), may be used. Copies of DA Form 2028-2 are attached in the back of the manual for your use. Please mail your recommended changes directly to Commander, US Army Tank-Automotive Command, ATTN: DRSTA-MB, Warren, MI 48090. A reply will be furnished directly to you.

**CHAPTER 1. INTRODUCTION**

Page

Section I. General .....	1-1
Section II. Battlefield Damage Assessment and Repair-Standards and Practices .....	1-6
Section III. Battlefield Damage Assessment and Repair - Responsibilities and Tasks .....	1-8

**CHAPTER 2. ASSESSING BATTLEFIELD DAMAGE**

Section I. General .....	2-1
Section II. Assessment Procedure .....	2-3
Section III. Combat Damage Report Forms .....	2-15

**CHAPTER 3. ENGINE**

Section I. General .....	3-1
Section II. Engine Failure .....	3-3
Section III. Engine Air Intake System .....	3-4
Section IV. Engine Exhaust System .....	3-6
Section V. Engine Lubrication System .....	3-7
Section VI. Engine Fuel System .....	3-11
Section VII. Engine Structure/Internal Components .....	3-14

CHAPTER 4. FUEL SUPPLY SYSTEM

Section I.	General .....	4-1
Section II.	Fuel Storage Systems .....	4-4

CHAPTER 5. COOLING SYSTEM

Section I.	General .....	5-1
Section II.	Cooling System BDAR .....	5-3

CHAPTER 6. ELECTRICAL SYSTEM

Section I.	General . . . . .	6-1
Section II.	Electrical BDAR .....	6-4

CHAPTER 7. POWERTRAIN/STEERING

Section I.	General .....	7-1
Section II.	Transmission .....	7-4
Section III.	Transfer Assemblies .....	7-5
Section IV.	Steering System .....	7-7

CHAPTER 8. TRACK AND SUSPENSION

Section I.	General .....	8-1
Section II.	Track .....	8-4
Section III.	Drive Sprocket and Roadwheels.....	8-7
Section IV.	Suspension Components.....	8-9

CHAPTER 9. HYDRAULIC SYSTEM

Section I.	General .....	9-1
Section II.	Hydraulic Configurations .....	9-2

CHAPTER 10. ARMOR

Section I.	General .....	10-1
Section II.	Improvised Armor .....	10-2

**CHAPTER 11. COMMUNICATIONS SYSTEMS**

Section I.	General .....	11-1
Section II.	General Operating Procedures .....	11-3
Section III.	Fault Assessment Tables and Procedures.....	11-6
Section IV.	Expedient Repair Procedures .....	11-15
Section V.	Common Vehicle Cording Diagrams .....	11-59

**APPENDIX A. ALTERNATE SOURCES OF SUPPLY**

Section I.	General .....	A-1
Section II.	Foreign Ownership of US Weapons System .....	A-2
Section III.	Expendable Supplies .....	A-6

**APPENDIX B. SPECIAL AND FABRICATED TOOLS**

Section I.	General .....	B-1
Section II.	Tools .....	B-2
Section III.	Test Equipment.....	B-7
Section IV.	Welding Expedients .....	B-9
Section V.	Containers .....	B-11

**APPENDIX C. POL SUBSTITUTES**

Section I.	General . . . . .	C-1
Section II.	Tables .....	C-4



## CHAPTER 1 INTRODUCTION

BDAR FIXES SHALL BE USED ONLY IN COMBAT  
AT THE DISCRETION OF THE COMMANDER  
AND SHALL BE REPAIRED BY STANDARD MAINTENANCE PROCEDURES  
AS SOON AS PRACTICABLE AFTER THE MISSION IS COMPLETED.

### SECTION I. General

#### 1-1. Purpose.

**a.** This technical manual (TM) is for use by operators, organizational, and direct support/general support maintenance personnel. It provides procedures and guidelines for battlefield repairs on the M113 Family of Vehicles (FOV) under the forward support maintenance concept during combat.

**b.** The purpose of Battlefield Damage Assessment and Repair (BDAR) is to rapidly return disabled combat vehicles to the operational commander by expediently fixing, by-passing, or jury-rigging components to restore the minimum essential systems required for the support of the specific combat mission or to enable the vehicle to self-recover. These repairs may be temporary and may not restore full performance capability.

#### 1-2. Scope.

**a.** This TM describes BDAR procedures applicable specifically to the M113 FOV. Expedient repairs of a general nature applicable to systems or sub-systems common to more than one combat vehicle are covered in TM 9-2350-276-BD.

**b.** Many expedient repair techniques helpful in preparing a vehicle for recovery are included in FM 20-22, Vehicle Recovery Operations. Details of such procedures are not duplicated in this TM, although certain quick fix battlefield operations which would, in some cases, prepare the vehicle for recovery or self-recovery will be described. Users of this manual should refer to FM 20-22 for further recovery-associated expedient repairs.

**c.** All possible types of combat damage and failure modes can not be predicted nor are all effective field expedient repairs known. This TM provides guidelines for assessing and repairing battlefield failures of the M113 FOV and is not intended to be a complete catalog of all possible emergency repairs. The repairs described here will serve as guidelines and will stimulate the experienced operator or mechanic to devise expedients as needed to rapidly repair equipment in a combat crisis.

**TM 9-2350-275-BD**  
**INTRODUCTION**

**1-3. Application.**

a. The procedures in this manual are designed for battlefield environments and should be used in situations where standard maintenance procedures are impractical. These procedures are not meant to replace standard maintenance practices, but rather to supplement them strictly in a battlefield environment. Standard maintenance procedures will provide the most effective means of returning a damaged vehicle to ready status provided that adequate time, replacement parts, and necessary tools are available. BDAR procedures are only authorized for use in an emergency situation in a battlefield environment, and only at the direction of the commander.

b. BDAR techniques are not limited to simple restoration of minimum functional combat capability. If full functional capability can be restored expeditiously with a limited expenditure of time and assets, this should be done.

c. Some of the special techniques in this manual, if applied, may result in shortened life or damage to components of the M113 FOV. The commander must decide whether the risk of having one less tank available for combat outweighs the risk of applying the potentially destructive expedient repair technique. Each technique gives appropriate warnings and cautions, and lists systems limitations caused by this action.

**1-4. Definitions.**

a. The term **“battlefield damage”** includes all incidents which occur on the battlefield and which prevent the vehicle from accomplishing its mission, such as combat damage, random failures, operator errors, accidents, and wear-out failures.

b. The term **“repair”** or **“fix”** in this manual includes any expedient action that returns a damaged part or assembly to a full or an acceptably degraded operating condition, including:

- (1) Short cuts in parts removal or installation.
- (2) Installation of components from other vehicles that can be modified to fit or interchange with components on the vehicle.
- (3) Repair using M113 FOV parts that serve a non-critical function elsewhere on the same tank for the purpose of restoring a critical function.
- (4) Bypassing of non-critical components in order to restore basic functional capability.
- (5) Expeditious cannibalization procedures.

- (6) Fabrication of parts from kits or readily available materials.
- (7) Jury-rigging.
- (8) Use of substitute fuels, fluids or lubricants.

c. **“Damage Assessment”** is a procedure to rapidly determine what is damaged, whether it is repairable, what assets are required to make the repair, who can do the repair (i.e. crew, maintenance team (MT), or maintenance support team (MST), and where the repair should be made. The assessment procedure includes the following steps:

- (1) Determine if the repair can be deferred, or if it must be done.
- (2) Isolate the damaged areas and components.
- (3) Determine which components must be fixed.
- (4) Prescribe fixes.
- (5) Determine if parts or components, materials, and tools are available.
- (6) Estimate the manpower and skill required.
- (7) Estimate the total time (clock-hours) required to make the repair.
- (8) Establish the priority of the fixes.
- (9) Decide where the fix shall be performed.
- (10) Decide if recovery is necessary and to what location.

d. A **Maintenance Team** (MT) consists of organizational mechanics, who may be trained in assessing battle damage and field repair procedures. MT are called to out-of-action vehicles to supplement (or confirm) the crew's original damage assessment. MT assessment determines if field repairs will be conducted or if recovery is required. Depending on available time, the MT will assist the crew in restoring the vehicle to mission capability.

e. A **Maintenance Support Team** (MST) consists of direct support/general support mechanics and technical specialists, who are trained in assessing battle damage in addition to their speciality. The MST is called by the MT when vehicle damage exceeds MT assessment capability or organizational repair capability.

**TM 9-2350-275-BD**  
**INTRODUCTION**

**f. The MT/MST assessor** is a senior member of the forward MT/MST. He is a systems mechanic/technician trained in BDAR techniques. He must know:

- (1) The unit's mission and the commander's requirements.
- (2) The maintenance capability of the unit, including the available skills, tools, repair parts, and materials.
- (3) How to detect contamination and effect decontamination of equipment.
- (4) The unit's maintenance workload.
- (5) The maintenance capability of all accessible rally and maintenance collection points.

**g. The term fully mission capable (FMC)** means that the vehicle can perform all its combat missions without endangering the life of the crew. To be FMC the vehicle must be complete and fully operable with no faults listed in the "Equipment is not ready/available if" column of the operator's Preventive Maintenance Checks and Services (PMCS).

**h. The term combat capable** means that the vehicle meets the minimum functional combat capability requirements. (See paragraph 1-10.)

**i. The term combat emergency capable** means that the vehicle meets the needs for specific tactical maneuver or firing missions; however, all systems are not functional. Also, additional damage due to the nature of an expedient repair may occur to the vehicle if it is used. The commander must decide if these limitations are acceptable for that specific emergency situation.

**j. The term self-recovery capable** means that the vehicle meets the needs for recovery under self-power. It could include hazardous equipment conditions such as partial brakes or limited steering.

**k. The term cannibalization** as used in this TM means any use of repair parts or components obtained from another combat vehicle either damaged or of lower priority to the immediate mission. In this TM, the term is used to include controlled exchange.

#### **1-5. BDAR Recommendations and QDR/EIR.**

**a. Personnel** originating new BDAR procedures should forward them directly to Commander, US Army Tank-Automotive Command, ATTN: DRSTA-MB-BDAR, Warren, MI 48090. Personnel are encouraged to develop and report new BDAR ideas, techniques and procedures.

b. Equipment Improvement Recommendations (EIR) may be submitted by anyone who knows of an unsatisfactory condition with equipment design or use. You do not have to show a new design or list a better way to do a procedure, just tell why the design is unfavorable or why a procedure is hard. EIR may be submitted on SF 368, Quality Deficiency Report. Mail these directly to Commander, US Army Tank-Automotive Command, DRSTA-MC, Warren, MI 48090. A reply will be sent directly to you.

## **SECTION II. Battlefield Damage Assessment and Repair - Standards and Practices**

### **1-6. BDAR Characteristics.**

BDAR capability requires simplicity, speed, and effectiveness. Some BDAR procedures include repair techniques that violate standard peacetime maintenance practices. In a combat emergency situation, greater risks are necessary and acceptable.

### **1-7. Training.**

The unit commander should ensure that an adequate number of members of his organization, including supervisors, are trained in BDAR procedures applicable to his equipment. Each vehicle crewman should be trained to perform initial battle damage assessment for his crew position.

### **1-8. Waiver of Precautions.**

Under combat conditions, BDAR may be performed on M113 FOV which are fueled and/or armed. Other similar precautions may be waived at the discretion of the commander, See paragraph 1-13e.

### **1-9. Environment.**

BDAR may be required in a chemically toxic environment or under other adverse conditions with severe limitations in personnel, facilities, equipment, and materials. Performance of repair tasks may be necessary while wearing protective gear. Expedient decontamination procedures are described in FM 3-220.

### **1-10. Serviceability and Operability (Operating Characteristics).**

The Minimum Functional Combat Capability (MFCC) criteria for the M113 FOV are as follows:

#### **NOTE**

**These criteria may be waived for recovery or if the tactical situation demands otherwise.**

#### **a. Mobility.**

- (1) Must have operational track on both sides of the tank.
- (2) Ability to transport ten combat loaded infantrymen.

- (3) No fuel leaks or other fire/safety hazards.
  - (4) Twenty percent of armor protection remaining.
  - (5) No coolant leaks.
  - (6) Drive train must be functional and must be capable of at least one forward gear.
  - (7) Power train performance degradation cannot exceed that level which would cause the vehicle to be incapable of traveling 4 miles per hour on a level, unimproved road.
  - (8) All driving laterals operable.
- b. Communications. Must have intercom between vehicle commander and driver.

**1-11. Permanent Repair.**

Upon completion of the mission, or at the next practicable opportunity, the vehicle will be recovered or evacuated to the appropriate maintenance facility for permanent standard repair as required.

### **SECTION III. Battlefield Damage Assessment and Repair - Responsibilities and Tasks**

#### **1-12. General.**

**a.** Battlefield damage assessment and repair procedures are applicable at all levels from crew through general support maintenance depending on the extent of the damage, the time available, the skills required, and the parts, components, tools, and materials available. Within these limits, each maintenance level will rapidly take whatever action is necessary and possible to restore the vehicle to the combat ready condition required for continuation of the mission.

**b.** Battlefield damage repair kits consisting of essential tools, may be carried on-board each vehicle to enable the crew to rapidly fix the simplest and most common types of damage/failure (See Appendix B, Special and Fabricated Tools).

#### **1-13. Commander and Crew.**

**a.** The crew of the damaged vehicle will make the first assessment immediately after damage has occurred. Crew members will provide the vehicle commander with an initial damage assessment which will include notice of system failure and all major vehicle systems visibly damaged, inoperative or impaired. If possible all systems will be checked at the same time by different crew members. If the failure is due to hostile fire, the report will include the location of impact and the manning status. Immediacy of the report is more important than how long it will take to get back into action. The initial report, therefore, may omit repair time estimates. The vehicle commander must make an initial out-of-action report to the platoon leader including these essential

- (1) Vehicle damaged (out-of-action or impaired).
- (2) Location of vehicle.
- (3) Firepower status.
- (4) Mobility status.
- (5) Manning status.
- (6) Current and anticipated enemy action.

**b.** If communication capability is damaged, the vehicle commander should approach the nearest friendly radio and make his report.

**c.** In the forward battle area it is imperative that the crew attempt to move the vehicle to a covered or concealed position to prevent additional combat damage. This is the first priority. If the vehicle is not capable of self movement, use any vehicle, including other combat vehicles to recover the vehicle or to get concealment. If this is



not possible, then the armament should at least be turned in the direction of engaging fires in order to limit damage and possibly return fire.

**d.** A Battlefield Damage Assessment/Repair Forms are provided in Chapter 2 to permit a systematic assessment by the crew. Assessment checks include looking at the damaged parts, determining what system they belong to, and deciding how they can be fixed or jury-rigged to permit immediate operation (full or partial).

**e.** A safety check should be made for any obvious hazards.

(1) Is there an ammunition round in the tube?

(2) Are any ammunition rounds critical due to shock, fire, or physical damage?

(3) Have any combustibles such as fuel, hydraulic fluid, or oil accumulated?

(4) Does wiring appear to be safe? Could arcing occur to stored ammo or leaking combustibles?

(5) Is the fire extinguishing system operational? If not, then one crew member should be stationed in the vehicle, either with a hand fire extinguisher or prepared to manually operate the vehicle fire extinguisher. A second crew member should be stationed outside the vehicle with the other fire extinguisher. He should also be prepared to manually actuate the engine compartment fire extinguisher.

**f.** A functional/operational test should be performed next on those systems which appear undamaged. For systems with a built-in self-test feature, this will be done. Only those systems found to be damaged or inoperative, shall be identified.

**g.** The vehicle commander shall report to the platoon leader the results of the crew's damage assessment, naming the major known causes of the vehicle's immobility and/or lack of fire power. If repair by crew is possible, he shall report a total estimated repair time and what functions may be restored.

**h.** The platoon leader will respond with directives and, if required, will call an MT to the location of the damaged vehicle for assistance. If possible, sufficient information will be provided to enable the MT to bring any needed repair parts or special tools.

**i.** The crew shall proceed to make any possible field expedient repairs to restore fire power, communications and/or vehicle mobility to the limit of their skills, materials, and tools available.

#### **1-14. Organizational Maintenance and Maintenance Teams (MT).**

**a.** The organizational maintenance team (MT) and assessor operate out of the company or battalion trains. The MT assessor performs his assessment and the

**TM 9-2350-275-BD**  
**INTRODUCTION**

maintenance team completes repairs if possible at the damage site. If the site is within direct fire or under enemy observation, movement to a more secure site in defilade may be necessary. This is still considered “on-site”.

**b.** If the vehicle has been left unattended in the forward battle area, the immediate area of the vehicle should be checked for mines and the vehicle should be checked for booby traps before starting the battle damage assessment. The MT should also make the safety checks listed in paragraph 1- 13e.

**c.** The MT assessment will be more thorough than the crew's, using organizational maintenance support tools and equipment as needed. MT assessment includes

- (1) Reviewing the crew’s out-of-action report, if available.
- (2) Interviewing commander and crew if available.
- (3) Visually inspecting damaged parts and systems.
- (4) Performing a self-test.
- (5) Making tests with organizational test equipment, if required.
- (6) Performing additional vehicle operational tests, as necessary.

**d.** Using this information and following the steps of paragraph 1-4c, the MT will:

- (1) Determine what must be repaired or replaced.
- (2) Determine sequence and priority of repair actions.
- (3) Estimate repair times for each repair task.
- (4) Total the repair task times and determine if the repairs can be performed in the time available.
- (5) Determine repair location and, if other than on-site, arrange for recovery of the vehicle to the repair site.

**e.** If all critical repairs can be made within the available time with the skills, materials, tools, and equipment at hand, the MT, assisted by the crew, will proceed with the on-site repair.

**f.** If the damage exceeds the repair capability of the MT, and time is available for an MST on-site fix, the MST shall be called.

**g.** If time for an MST on-site fix is not available, but the vehicle is repairable, the MT shall provide for recovery of the vehicle to a designated collection point.

**h.** If the vehicle is not repairable, the MT shall provide for one of the following:

(1) Recovery to a maintenance collection point for evacuation to the rear.

(2) On-site stripping (if approved by Commander, coordinated with support maintenance).

(3) Abandonment/destruction (if directed by commander).

**i.** Vehicle hulls should never be abandoned if recovery/evacuation is possible because hulls can almost always be rebuilt, no matter how badly damaged they are. If the vehicle is damaged catastrophically and evacuation is not possible, remove items in the following order:

(1) Needed spares on-site.

(2) Sensitive, high value, limited size items.

(3) Other needed spares or repair parts.

**j.** If the vehicle is contaminated, the MT shall mark the vehicle with contamination markers and arrange for recovery to a decontamination site.

#### **1-15. Direct Support/General Support Maintenance Team.**

**a.** The MST shall assist the MT as needed, using direct support maintenance tools and equipment. MST assessment and repair procedures are the same as those of the MT except at a higher maintenance level. If possible, the MT will tell the MST what tools and spare parts are needed to perform the repairs. While waiting for the MST to arrive, the crew, under the supervision of the MT, will open up the vehicle and make it ready for the MST to perform the BDAR when it arrives.

**b.** Damaged vehicles removed to designated repair sites shall be selected for repair by the MST in order of:

(1) Most essential to the completion of the mission.

(2) can be repaired in the least amount of time.

#### **1-16. Time Limits for Repairing Damage.**

**a.** In combat, the time available for BDAR is limited. One of the factors to be considered in the selection of a repair site is the amount of time available at the site based on the tactical situation. Every assessment must include an estimate of total

**TM 9-2350-275-BD**  
**INTRODUCTION**

elapsed time for all tasks required to restore the vehicle. The time available at the selected repair site must equal or exceed the estimated time required to accomplish all tasks associated with the BDAR.

**b.** Determining where BDAR will take place should be based on the guidelines in Table 1-1. These are general rules which must be adjusted by the commander based on his best estimate of how the most responsive maintenance support can be provided. He must consider the tactical situation, maintenance backlog, personnel, tools, TMDE, and repair parts available. The guidelines are based on a defensive scenario and can be extended when applied to the offense.

**Table 1-1. Summary of BDAR Time Guidelines**

LOCATION	ELEMENTS PERFORMING BDAR	TIME GUIDELINES
Breakdown Site	1. Operator/Crew 2. Battalion Maintenance Team (MT) 3. Maintenance Support Team (MST) from Forward Support Maintenance Company	2 Hours
Battalion Trains (OMCP)	1. Battalion Maintenance Platoon 2. Maintenance Support Team (MST) from Forward Support Maintenance Company 3. Maintenance Support Team (MST) from Maintenance Battalion.	6 Hours
Brigade Support Area	1. Forward Support Maintenance Co. 2. Maintenance Support Team (MST) from Maintenance Battalion 3. Maintenance Support Team (MST) from COSCOM	24 Hours
Division Support Area	1. Maintenance Battalion 2. Maintenance Support Team (MST) from COSCOM	36 Hours
Corps Support	1. COSCOM Maintenance Companies	96 Hours

**1-17. Recording BDAR Repairs.**

**a.** All components of an M113 FOV, which are repaired using BDAR or other expedient techniques, shall be marked with a tag, DD Form 1577, or similar conspicuous tag. It is not necessary to fill out the form. The purpose of marking an item which has been repaired using BDAR techniques is to quickly enable mechanics to recognize these parts when the vehicle is subsequently returned for authorized permanent repair.

**b.** Since it is impractical to attach tags to expediently repaired components located on the outside of the vehicle, the fix shall be noted on DD Form 1577 or similar tag, and the tags stored in the compartment normally reserved for the vehicle log book.

**c.** A tag should also be placed conspicuously in the vehicle commander's position when a BDAR procedure has resulted in a degraded operating capability. This tag should be marked "BDAR" and noted with its specific limitations or cautions.

**d.** When a component is cannibalized from a repairable vehicle, a tag should be attached in the space created by the missing part to alert downstream repair personnel quickly that the part has been removed.

**e.** When the vehicle is recovered/evacuated for permanent standard repair, and DA Forms 2404 and 2407 are used, the notation "BDAR" shall be added in the space provided for description of deficiencies.

**f.** DA PAM 738-750 provides for disposition of DA Form 2404 and copy number 3 of DA form 2407. When "BDAR" is noted on these forms, they shall be mailed to: Combat Data Information Center, AFFDL/FES/CDIC, Wright Patterson AFB, Ohio 45433. The information on these forms will provide data for designing vehicles to be less susceptible to combat damage and easier to repair when damaged.

## CHAPTER 2

### ASSESSING BATTLEFIELD DAMAGE

BDAR FIXES SHALL BE USED ONLY IN COMBAT  
AT THE DISCRETION OF THE COMMANDER  
AND SHALL BE REPAIRED BY STANDARD MAINTENANCE PROCEDURES  
AS SOON AS PRACTICABLE AFTER THE MISSION IS COMPLETED.

#### SECTION I. General

##### 2-1. Scope

This chapter provides guidelines to use to assess battlefield damage to the M113 Family of Vehicles (FOV). It directs you to inexpedient repair procedure, or to the standard system TM if an expedient repair procedure for your problem doesn't exist.

##### 2-2. General

Use this TM in conjunction with the vehicles Technical Manuals (TM) and Lubrication Order (LO). This chapter explains how to use this manual to assess and fix battlefield damage that prevent the M113 FOV from moving, shooting, and/or communicating. This chapter contains the general fault assessment tables, general troubleshooting and maintenance instructions including combat damage report forms. General fault assessment tables, specific fault assessment tables, and detailed assessment procedures are used to locate the damage; and an expedient repair procedure tells how to fix the damage. An index of the expedient repair procedures is located in each chapter. If you don't know or aren't sure of exactly what your problem is, you should use the assessment tables and procedures to find the fault.

##### 2-3. Application

Use the following steps to find and fix battlefield damages:

- a. Do the Preventive Maintenance Checks and Services (PMCS) in the TM and LO. At the same time look for obvious damage to the vehicle.
- b. If applicable, do the troubleshooting/repair recommended in the TM.
- c. If you find the problem, determine its effect on the operation (mobility, firepower, or communication) of the vehicle.

TM 9-2350-275-BD  
ASSESSING BATTLEFIELD DAMAGE

**d.** If you can't fix the problem using the PMCS's and procedures in the standard TM and LO, use the assessment table 2-1 to assess and fix the problem.

**e.** If the problem does not affect vehicle operation, the commander will decide whether to attempt to fix the problem or continue with the mission.

**f.** If the damage does affect vehicle operation, do one of the following:

(1) Replace the bad part/assembly with a good one (from supply or other source or vehicle).

(2) Replace the bad part/assembly with a substitute, if one exists.

(3) Use the expedient repair procedures in this manual to repair the damage.

After repairing the damaged system, replace all lost fluids and/or lubricants. If the ones specified by the standard LO or TM are not available, refer to Appendix C for a possible substitute.

## **SECTION II. Assessing Battlefield Damage**

### **2-4. General.**

**a.** This section provides an overall damage assessment procedure to evaluate the mobility, communications and firepower functions of individual vehicles.

**b.** The assessment procedures are designed to assure that all necessary aspects of a combat vehicle capability are evaluated during the assessment process. The procedures refer you to:

- (1) procedures in this manual if a “quick-fix” is possible,
- (2) the standard TM if the best repair is covered in the system TM, or
- (3) a higher maintenance level if access to devices or materials to do the quick-fix are available only at those levels.

**c.** Each procedure:

- (1) contains general information about the problem,
- (2) lists materials and/or tools required other than those commonly available to the crew, MT, and MST (If the listed items are not available, improvise. Anything that will do the job is acceptable.),
- (3) lists the estimated number of soldiers needed and the estimated time required to complete the repair,
- (4) states the operational limitations caused by the repair action before experiencing further damage/degradation to the vehicle,
- (5) provides other expedient options you can use depending on the availability of personnel, materials, tools, and/or time (This does not include standard maintenance procedures or recovery).

**d.** Following each assessment procedure is an index of the procedures contained in that chapter. If you know exactly what your problem is, you can use the index to find the proper expedient repair procedure.

**e.** Additional data is contained in the Appendices.

(1) Appendix A lists alternate sources of supply to include foreign ownership of US combat vehicles and expendable supplies which are recommended for use to implement various BDAR repairs.





**b.** All assessment procedures follow the sequence:

- (1) visually inspect (repair, if necessary),
- (2) functionally test (repair, if necessary) and,
- (3) assess the performance.

The field fixes will enable the crew to continue operations in some cases, but will usually be most useful to the MT/MST for scheduling and accomplishing fix-forward repairs and assessing combat capabilities for reporting to commanders.

**c.** There are three kinds of assessments performed on damaged equipment.

- (1) The first assessment is extent and kind of damage and how it affects vehicle operation and capabilities.
- (2) The second is whether the damage needs to be repaired and,
- (3) The third is assessment of where and how to repair the damage.

**d.** Assessments of damage may be made in turn by operator/crew, MT, and MST assessors.

- (1) Extent and kind of damage is readily assessable.
- (2) Whether or not to repair the damage may be readily assessable. However, whether to attempt repair and when and how to repair the damage may be judgement calls. No procedure can take all possible situations into account. Assessment of whether the damage needs to be repaired will be made jointly by the MT and vehicle commander as they evaluate the vehicle for further operation or recovery.
- (3) Assessment of where and how to repair the damage will be made by the MT usually with some suggestions by crew/operator. MST's may redirect or change MT's decisions.

**2-6. Overall Vehicle Assessment Procedure.**

**a.** This procedure can be used by the crew, but it will be of more use to an MT or MST assessor working to "quick-fix" vehicles for a mission or self-recovery. The procedure provides for assessing the kind of damage and determining:

- (1) the effect of the damage and if it needs to be fixed,
- (2) if the damage can be fixed using BDAR or if only regular maintenance

TM 9-2350-275-BD  
ASSESSING BATTLEFIELD DAMAGE

operations can fix it,

(3) how long it will take to fix it,

**b.** This is accomplished by structuring this manual in rank order, from the vehicle three-function overview down to the specific. Each major function (shoot, move, communicate) and each subsystem that makes up a part of providing that function, has a stand-alone assessment procedure to make it easier to quantify each significant problem encountered in battlefield damaged equipment.

**c.** As an example, a vehicle develops an engine speed control problem. The overall vehicle assessment table directs the user to perform a number of visual and functional checks, which will narrow down the number of areas possibly at fault. The overall vehicle assessment table provides references to chapter and/or sections dealing with a subsystem in which the problem may be found. Additional assessment procedures in that chapter will either eliminate further assessment in that area or confirm the likelihood of a problem in that area by directing the user to check out specific assemblies or components. Assessment procedures in the beginning of each chapter provide references to specific paragraphs which may expediently solve the problem.

**d.** At any point on each of the assessment levels, the assessor can abort the procedure and direct recovery, evacuation or other actions if the tactical situation dictates.

**e.** Refer to Table 2-1, Vehicle/System Assessment to begin the assessment process.

**Table 2-1. Vehicle/System Assessment.**

<u>ITEM/ACTION</u>	<u>FAULT ISOLATION</u>	<u>BDAR REFERENCE</u>
--------------------	------------------------	-----------------------

NOTE

Items checked in this procedure must work to provide minimum functional combat capability. Even if all systems work the vehicle may be unsafe and may not satisfy normal required operating capabilities or may not receive mission-essential maintenance.

**A. MOBILITY ASSESSMENT.**

**1. VISUALLY INSPECT....**

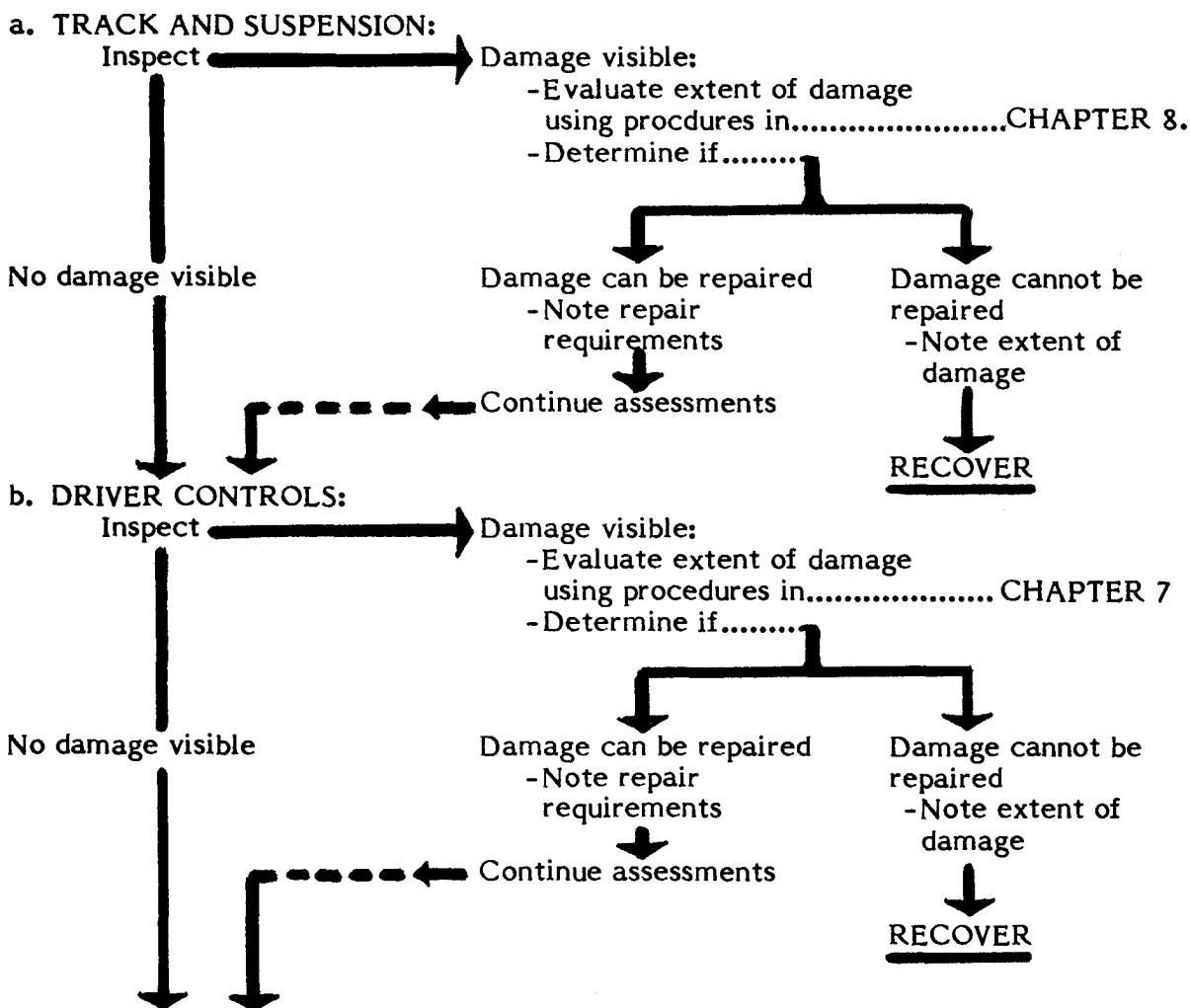

TM 9-2350-275-BD  
 ASSESSING BATTLEFIELD DAMAGE

Table 2-1. Vehicle/System Assessment (Cent).

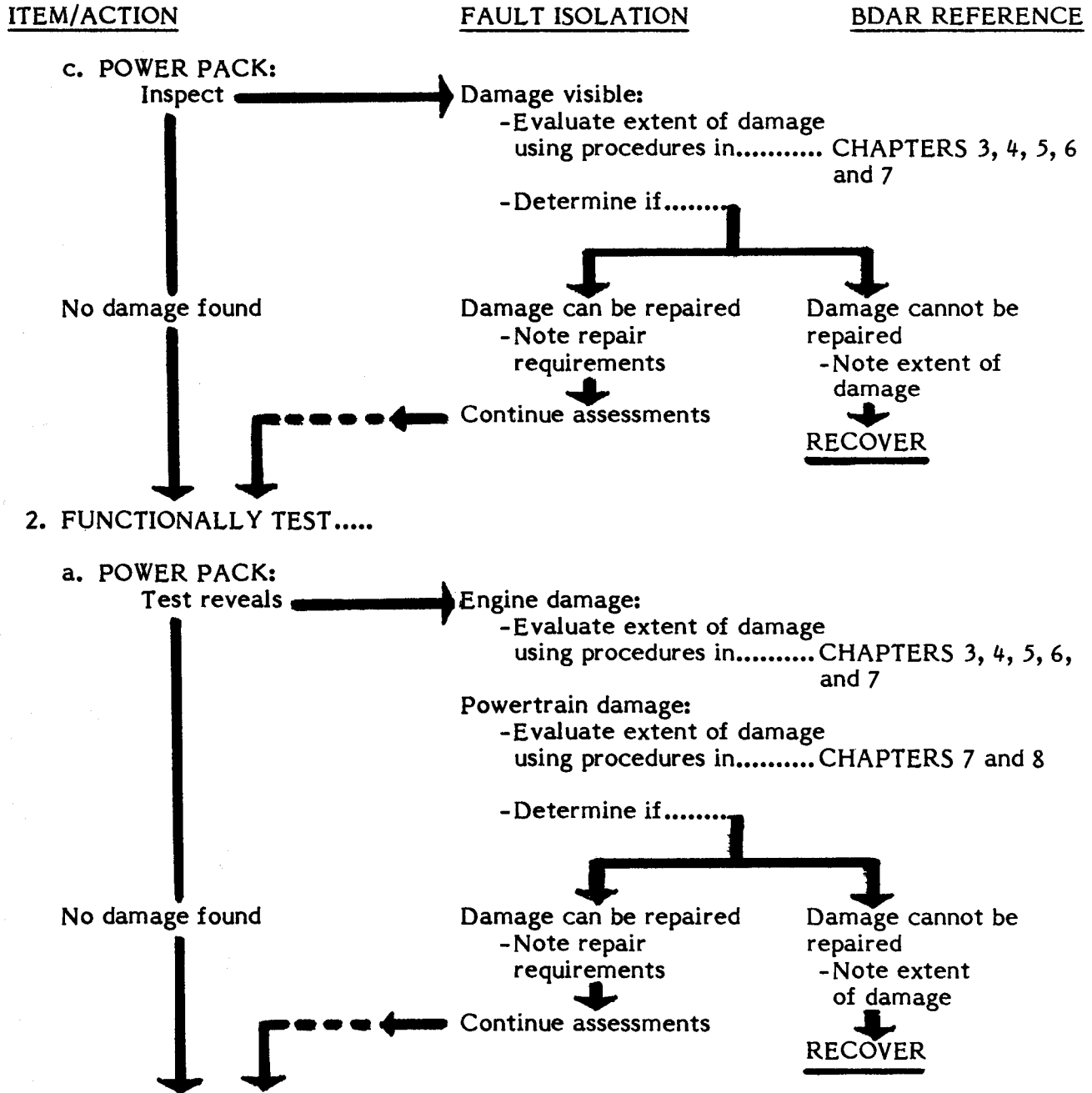
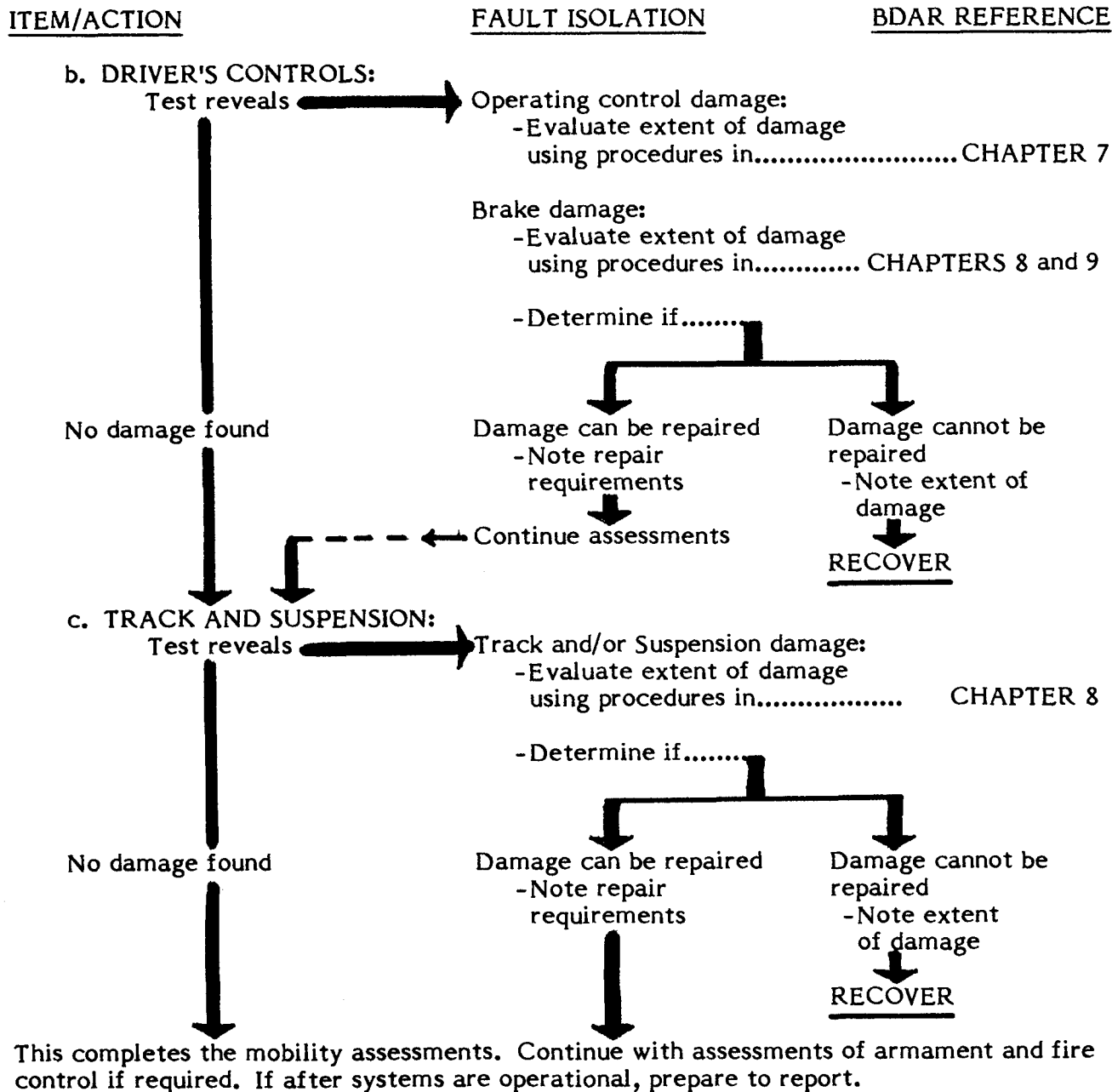

Table 2-1. Vehicle/System Assessment (Cent).



**Table 2-1. Vehicle/System Assessment (Cont).**

<u>ITEM/ACTION</u>	<u>FAULT ISOLATION</u>	<u>BDAR REFERENCE</u>
--------------------	------------------------	-----------------------

B. COMMUNICATIONS ASSESSMENTS . . . .

1. VISUALLY INSPECT . . . .

**WARNING**

Before assessing and handling communications equipment turn off the power to all components of the communications system. Damaged equipment can cause severe shock to personnel and additional damage to equipment.

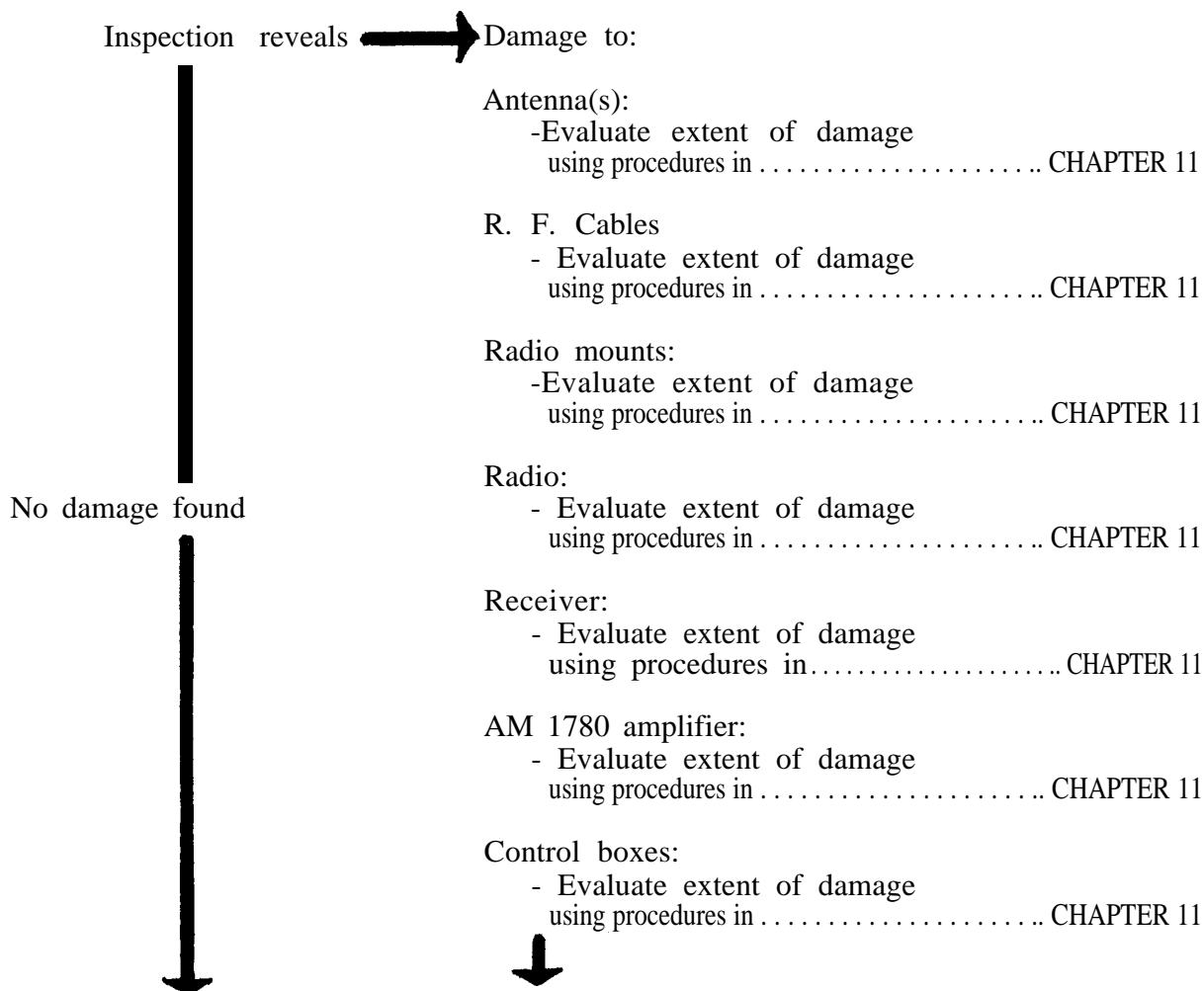

Table 2-1. Vehicle/System Assessment (Cent).

<u>ITEM/ACTION</u>	<u>FAULT ISOLATION</u>	<u>BDAR REFERENCE</u>
<p>No damage found</p>	<p>CVC helmets: -Evaluate extent of damage using procedures in.....CHAPTER 11</p>	
	<p>Speech security system: -Evaluate extent of damage using procedures in.....CHAPTER 11</p>	
	<p>-Determine if.....</p> <div style="display: flex; justify-content: space-around;"> <div style="text-align: center;"> <p>Damage can be repaired -Note repair requirements</p> </div> <div style="text-align: center;"> <p>Damage cannot be repaired -Note extent of damage</p> </div> </div>	
	<p>Continue assessments</p>	
<p>2. FUNCTIONAL TEST PRECONDITIONS....</p>		

**NOTE**

Insure that no current-conducting wires will short out to each other or to ground, when power to equipment is turned on.

**NOTE**

Turn on power to each communication system as it is functionally tested.

3. SELF-TEST AND FUNCTIONAL CHECKS . . . .

- a. RADIO:
  - Functional test reveals → Radio does not work  
-Evaluate cause of malfunction  
using procedures in.....CHAPTER 11
  - No damage found
- b. AUXILIARY RECEIVER:
  - Functional test reveals → Auxiliary receiver does not work  
-Evaluate cause of malfunction  
using procedures in.....CHAPTER 11
  - No damage found



**TM 9-2350-275-BD  
ASSESSING BATTLEFIELD DAMAGE**

**Table 2-1. Vehicle/System Assessment (Cent).**

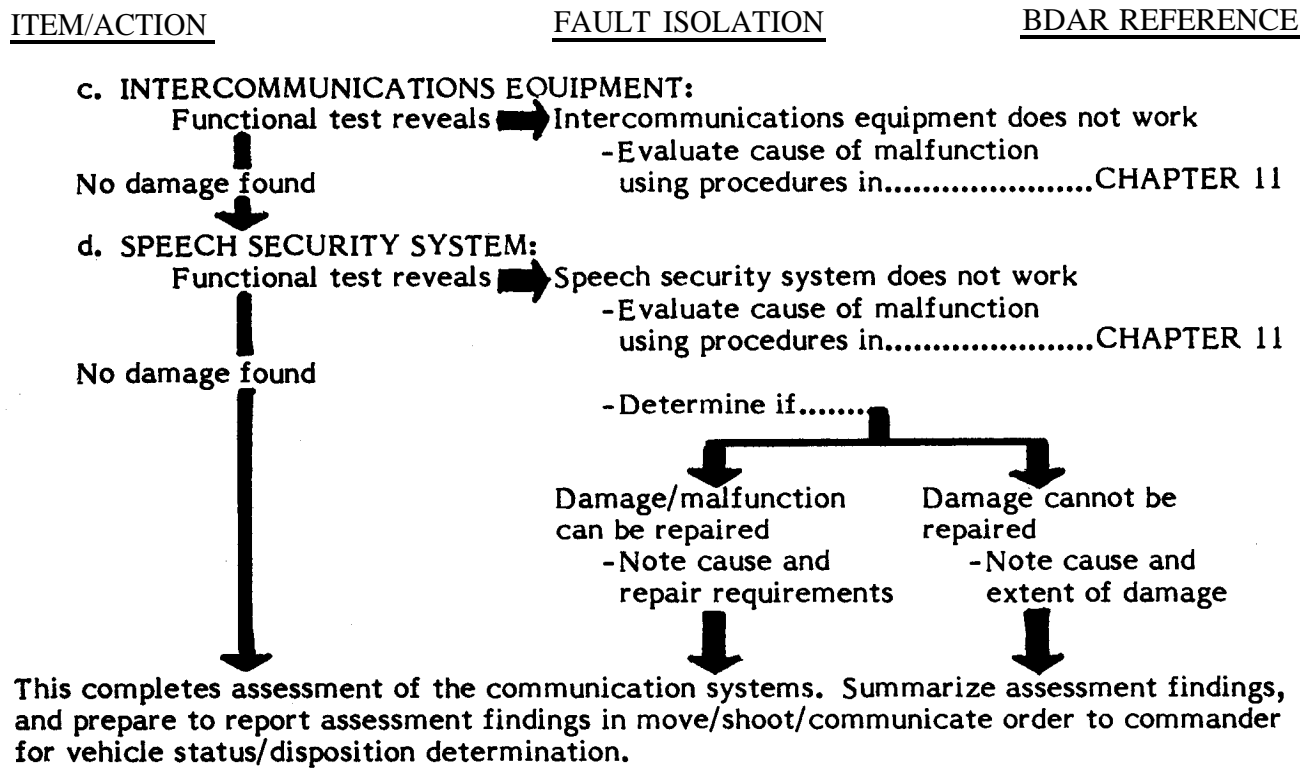

**2-7. Index of Failures and Field Fixes**

Table 2-2 below lists the BDAR procedures in this TM in alphabetical order,

**Table 2-2. BDAR Procedural Index**

<b>FAILURE</b>	<b>PARA</b>
Air Cleaner Damaged.....	3-6
Brake Linkage Damaged.....	7-7
Cables Are Too Short, BDAR Installation.....	11-31
Coaxial Cable Repair .....	11-29
Common Vehicle Cording Diagrams .....	11-36
Connecting Rod or Rod Bearing Failure .....	3-17
Coolant Frozen .....	5-6
Drive Sprocket or Hub Bolts Sheared.....	8-6
Engine Malfunctions.....	3-4
Engine Transmission Housing Damage .....	3-16
Fiberglass Whip Antenna Replacement.....	11-20
Field Expedient Radio Remote.....	11-34
Field Expedient Radio Mount Repair .....	11-24
Field Safety Switch Defective .....	6-7
Foreign Equipment Interchangeability (AN/VRC-12 Series) .....	11-25
Foreign Equipment Interchangeability (Allied Radios).....	11-27
Foreign Equipment Interchangeability y (Soviet Intercom R- 124) .....	11-28
Foreign Equipment Interchangeability (Soviet Radio R-123M) .....	11-26
Fuel Injector Line Rupture .....	4-5
Fuel Pump Interchangeability y.....	4-6
Gearshift Linkage Broken .....	7-4
General Interchangeability Information (Radio Components) .....	11-35
Ground Plane Antenna, Field Expedient.....	11-21
Injector Failure.....	3-13
Intercom Cable Repair.....	11-30
Intercom System, Field Expedient.....	11-22
Isolation of Non-Essential Systems (General) .....	11-32
Isolation of Non-Essential Systems (Voltage Suppressors).....	11-33
Metal Tube Damaged.....	5-5
Metallic Whip Antenna Broken .....	11-17
Metallic Whip Antenna Replacement.....	11-18
Metallic Whip Antenna Replacement; Long Wire Antenna.....	11-19

**TM 9-2350-275-BD  
ASSESSING BATTLEFIELD DAMAGE**

**Table 2-2. BDAR Procedure Index (Continued)**

<b>FAILURE</b>	<b>PARA</b>
Neutral Safety Switch Defective .....	6-6
<b>Oil Level Low</b> .....	3-10
Oil Pan Holes.....	3-11
Oil Pump Failure .....	3-9
Piston, Engine, Perforated Head .....	3-15
Radio System, Field Expedient .... . . . .	11-23
Roadwheel Arm Damaged.....	8-9
Roadwheel Arm Housing Sheared.....	8-8
Roadwheel/Hub Damaged.....	8-7
Short-Tracking, Idler Assembly Damaged .....	8-5
Starter Failure.....	6-5
Suspension Component Interchangeability.....	8-10
Throttle Linkage Damaged.....	3-14
Track, Partially Thrown.....0.....00.	8-4
Transfer Assembly Interchangeability.....	7-5
V-Belt, Missing or Broken.....	5-7

### **SECTION III. Battlefield Damage Assessment/Repair Forms**

#### **2-8. General.**

**a.** This section illustrates and describes the forms used in battlefield damage assessment. The forms are designed to assist Commanders in rapidly assessing battlefield damaged equipment, systematically assessing equipment to determine which subsystem(s) are affected, and the time, personnel and material required to effect repair. These forms will also assist in performing “vehicle triage.” Vehicle triage is defined as a system of deciding in which order battlefield damaged equipment will receive repair, according to time, urgency, material and personnel required to accomplish the repair. The forms illustrated are to be used in assessing battlefield damage.

#### **NOTE**

These forms are locally reproducible and should be reproduced in necessary quantities to support local needs.

**b.** The battlefield damage assessment/repair forms are designed to assure that all necessary aspects of combat capability are evaluated during the assessment process.

**c.** All assessment procedures follow the sequence, (1) visually inspect (repair if necessary), (2) functionally test, (repair if necessary), and (3) assess the performance. The net assessment and field fixes will enable the vehicle to continue the mission or self-recover, but will typically be more useful to the MT/MST for scheduling and accomplishing both BDAR “quick fixes” and fix-forward repairs. Battlefield damage assessment will also provide the Commander with the necessary information for timely decisions as to whether to continue to “fight the vehicle” or recover it at the appropriate level.

**d.** Reporting of battlefield damage should be accomplished in accordance with local Standing Operating Procedures (SOP).

There are four forms to be used when assessing battlefield damage, BDARF-5, (System Summary), BDARF-6 (Hull Damage Report), BDARF-7 (Turret Damage Report), BDARF-8 (Communications Damage Report). These forms can be used by the crew, a MT, or a MST.

(1) BDARF-5 is used to determine:

Can the vehicle move, shoot and communicate?

What subsystems are affected?

Is the damage repairable?

If repairable, are there limitations?

Estimated time to repair?

TM 9-2350-275-BD  
ASSESSING BATTLEFIELD DAMAGE

Estimated number of personnel to effect repair.

What materials are required?

Recover status (recovery vehicle required or self-recovery.)

Once these questions are answered, a determination can be made as to whether the vehicle should be repaired on-site, recovered to a collection point and repaired, or recovered to the rear.

(2) BDARF-6, -7, and -8 address specific systems and subsystems. These forms are designed to assist the assessor to rapidly assess the damage and rapidly determine the appropriate BDAR fix. The portion of this form which addresses parts should be filled out only when the tactical situation permits. Where possible these forms should follow the damaged equipment or be sent to the rear as a record of what damages occurred and what repairs were effected and where.

SYSTEM SUMMARY

Serial No. \_\_\_\_\_

<u>Vehicle Status</u>	<u>Can Vehicle Be Repaired?</u>				<u>Recovery Status</u>	
	<u>Yes</u>	<u>No</u>	<u>Yes</u>	<u>No</u>	<u>Yes</u>	<u>No</u>
Move _____	<input type="checkbox"/>	<input type="checkbox"/>	<input type="checkbox"/>	<input type="checkbox"/>	Self Recover	<input type="checkbox"/> <input type="checkbox"/>
Shoot _____	<input type="checkbox"/>	<input type="checkbox"/>			Can be Towed	<input type="checkbox"/> <input type="checkbox"/>
Communicate _____	<input type="checkbox"/>	<input type="checkbox"/>			Transportable	<input type="checkbox"/> <input type="checkbox"/>

<u>Sub-System</u>	<u>Repair</u>	<u>Recover</u>	<u>Limitations</u>	<u>Estimated -</u>	
				<u>Time</u>	<u>Personnel</u>
Engine	<input type="checkbox"/>	<input type="checkbox"/>	_____	_____	_____
Transmission/Final Drive	<input type="checkbox"/>	<input type="checkbox"/>	_____	_____	_____
Fuel System	<input type="checkbox"/>	<input type="checkbox"/>	_____	_____	_____
Electrical System	<input type="checkbox"/>	<input type="checkbox"/>	_____	_____	_____
Track & Suspension	<input type="checkbox"/>	<input type="checkbox"/>	_____	_____	_____
Hydraulic System	<input type="checkbox"/>	<input type="checkbox"/>	_____	_____	_____
Armor & Ammunition Stowage	<input type="checkbox"/>	<input type="checkbox"/>	_____	_____	_____
Armament & Fire Control	<input type="checkbox"/>	<input type="checkbox"/>	_____	_____	_____
Communications	<input type="checkbox"/>	<input type="checkbox"/>	_____	_____	_____
Other _____	<input type="checkbox"/>	<input type="checkbox"/>	_____	_____	_____
			Total	_____	_____

Material Requirements

<u>Expendables</u>	<u>Parts</u>	<u>NSN</u>	<u>Tools</u>	<u>NSN</u>
1. _____	_____	_____	_____	_____
2. _____	_____	_____	_____	_____
3. _____	_____	_____	_____	_____
4. _____	_____	_____	_____	_____
5. _____	_____	_____	_____	_____

Remarks

HULL DAMAGE ASSESSMENT AND REPAIR

Serial No. \_\_\_\_\_

TM 9-2350-275-BD  
ASSESSING BATTLEFIELD DAMAGE

Estimated Total Time \_\_\_\_\_

No. of Mechanics \_\_\_\_\_

Exchanged Parts

NSN

- |    |       |       |
|----|-------|-------|
| 1. | _____ | _____ |
| 2. | _____ | _____ |
| 3. | _____ | _____ |
| 4. | _____ | _____ |
| 5. | _____ | _____ |

Cannibalized Parts

NSN

- |    |       |       |
|----|-------|-------|
| 1. | _____ | _____ |
| 2. | _____ | _____ |
| 3. | _____ | _____ |
| 4. | _____ | _____ |
| 5. | _____ | _____ |

<u>Engine System</u>	<u>Time</u>	<u>Personnel</u>	<u>Transmission &amp; Final Drives</u>	<u>Time</u>	<u>Personnel</u>	<u>Fuel System</u>	<u>Time</u>	<u>Personnel</u>
1. Starter	_____	_____	1. Transmission will not shift	_____	_____	1. Fuel Tanks	_____	_____
2. Oil Tank	_____	_____	2. Broken Linkage	_____	_____	2. Fuel Lines	_____	_____
3. Air Induction System	_____	_____	3. Tank will not Steer	_____	_____	3. Fuel Filters	_____	_____
4. Air Cleaner	_____	_____	4. Final Drive Locked	_____	_____	4. Fuel Pumps	_____	_____
5. Oil Filter	_____	_____	5. Transmission Leaks	_____	_____	5. _____	_____	_____
6. Low Oil Pressure	_____	_____	6. Parking Brakes	_____	_____	6. _____	_____	_____
7. Drain Valve	_____	_____	7. Service Brakes	_____	_____	7. _____	_____	_____
8. Accessory Driveshaft	_____	_____	8. Oil Coolers	_____	_____			
9. _____	_____	_____	9. _____	_____	_____			
10. _____	_____	_____	10. _____	_____	_____			
11. _____	_____	_____						

HULL DAMAGE ASSESSMENT AND REPAIR (Continued)

Serial No. \_\_\_\_\_

Electrical System

	<u>Time</u>	<u>Personnel</u>
1. Wiring Harness	_____	_____
2. Slipring	_____	_____
3. Batteries	_____	_____
4. Circuit Breakers	_____	_____
5. Power Distribution Box	_____	_____
6. _____	_____	_____
7. _____	_____	_____
8. _____	_____	_____
Total	_____	_____

Track & Suspension

	<u>Time</u>	<u>Personnel</u>
1. Compensating Idlers	_____	_____
2. Track Adjusting Link	_____	_____
3. Road Wheel Arms	_____	_____
4. Roadwheels	_____	_____
5. Support Rollers	_____	_____
6. Sprockets	_____	_____
7. Shock Absorbers	_____	_____
8. Torsion Bars	_____	_____
9. Track Assembly	_____	_____
10. _____	_____	_____
11. _____	_____	_____
12. _____	_____	_____
Total	_____	_____

Hydraulic System

	<u>Time</u>	<u>Personnel</u>
1. Hydraulic Lines	_____	_____
2. Hydraulic Fluid	_____	_____
3. _____	_____	_____
4. _____	_____	_____
5. _____	_____	_____
Total	_____	_____

Other

	<u>Time</u>	<u>Personnel</u>
1. Driver's Controls	_____	_____
2. Driver's Instruments	_____	_____
3. _____	_____	_____
4. _____	_____	_____
5. _____	_____	_____
Total	_____	_____

TM 9-2350-275-BD  
ASSESSING BATTLEFIELD DAMAGE



TURRET DAMAGE ASSESSMENT AND REPAIR

Serial No. \_\_\_\_\_

TM 9-2350-275-BD  
ASSESSING BATTLEFIELD DAMAGE

Estimated Total Time \_\_\_\_\_  
No. of Mechanics \_\_\_\_\_

Exchanged Parts	NSN	Cannibalized Parts	NSN
1. _____	_____	1. _____	_____
2. _____	_____	2. _____	_____
3. _____	_____	3. _____	_____
4. _____	_____	4. _____	_____

<u>Electrical System</u>	<u>Time</u>	<u>Personnel</u>
1. Turret Power	_____	_____
2. Slipring	_____	_____
3. Circuit Breakers	_____	_____
4. Wiring Harnesses	_____	_____
5. _____	_____	_____
6. _____	_____	_____
Total	_____	_____

<u>Hydraulic System</u>	<u>Time</u>	<u>Personnel</u>
1. Aux Hydraulic Pump	_____	_____
2. Hydraulic Fluid	_____	_____
3. Hydraulic Reservoir	_____	_____
4. Tubes & Hoses	_____	_____
5. Accumulator	_____	_____
6. _____	_____	_____
7. _____	_____	_____
Total	_____	_____

<u>Armor &amp; Ammo Stowage</u>	<u>Time</u>	<u>Personnel</u>
1. Ammo Stowage Racks	_____	_____
2. Ammo Ready Rack	_____	_____
3. _____	_____	_____
4. _____	_____	_____
Total	_____	_____

<u>Fire Control</u>	<u>Time</u>	<u>Personnel</u>
1. CMDR Control Handle	_____	_____
2. CMDR Weapon Sight	_____	_____
3. Gunner's Primary Sight	_____	_____
4. Gunner's Aux Sight	_____	_____
5. Range Finder	_____	_____
6. Stabilization System	_____	_____
7. Cross Wind Sensor	_____	_____
8. Wiring Harness	_____	_____
9. Gunner's Control Handle	_____	_____
10. Manual Traverse & Elevation	_____	_____
11. Loader's Panel	_____	_____
12. Blasting Machine	_____	_____
13. _____	_____	_____
14. _____	_____	_____
Total	_____	_____

<u>Armament</u>	<u>Time</u>	<u>Personnel</u>
1. Bore Evacuator	_____	_____
2. Gun Tube	_____	_____
3. Breech Group	_____	_____
4. Main Gun Mount	_____	_____
5. _____	_____	_____
6. _____	_____	_____
Total	_____	_____

COMMUNICATIONS DAMAGE ASSESSMENT AND REPAIR

Serial No. \_\_\_\_\_

TM 9-2350-275-BD  
ASSESSING BATTLEFIELD DAMAGE

Exchanged Parts	<u>NSN</u>	<u>Cannibalized Parts</u>	<u>NSN</u>
1. _____	_____	1. _____	_____
2. _____	_____	2. _____	_____
3. _____	_____	3. _____	_____
4. _____	_____	4. _____	_____

	<u>Time</u>	<u>Personnel</u>
1. Intercommunications	_____	_____
2. Receiver/Transmitter	_____	_____
3. Antennas	_____	_____
4. AM 1780	_____	_____
5. Security	_____	_____
6. Cables	_____	_____
7. _____	_____	_____
8. _____	_____	_____
Total	_____	_____

2-21 (2-22 blank)

CHAPTER 3  
ENGINE

BDAR FIXES SHALL BE USED ONLY IN COMBAT  
AT THE DISCRETION OF THE COMMANDER  
AND SHALL BE REPAIRED BY STANDARD MAINTENANCE PROCEDURES  
AS SOON AS PRACTICABLE AFTER THE MISSION IS COMPLETED.

**SECTION I. General**

**3-1. General.**

The M113 FOV is powered by a V-6, liquid cooled, two-cycle supercharged, diesel engine 6V53. Engine damage can be detected by several different methods.

- a. Abnormal oil pressure or temperature readings or warning lights.
- b. Abnormal noises.
- c. Abnormal amounts or coloration of exhaust smoke.
- d. Sudden loss of power or excessive fuel consumption.

This chapter gives various expedient fixes which may restore the tanks mobility in event of engine system failure.

**3-2. Assessment Procedure**

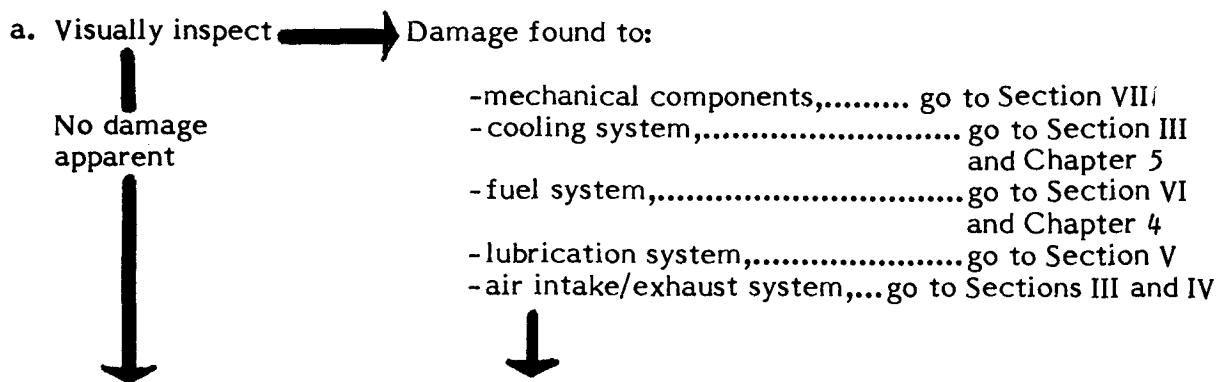

TM 9-2350-275-BD  
ENGINE

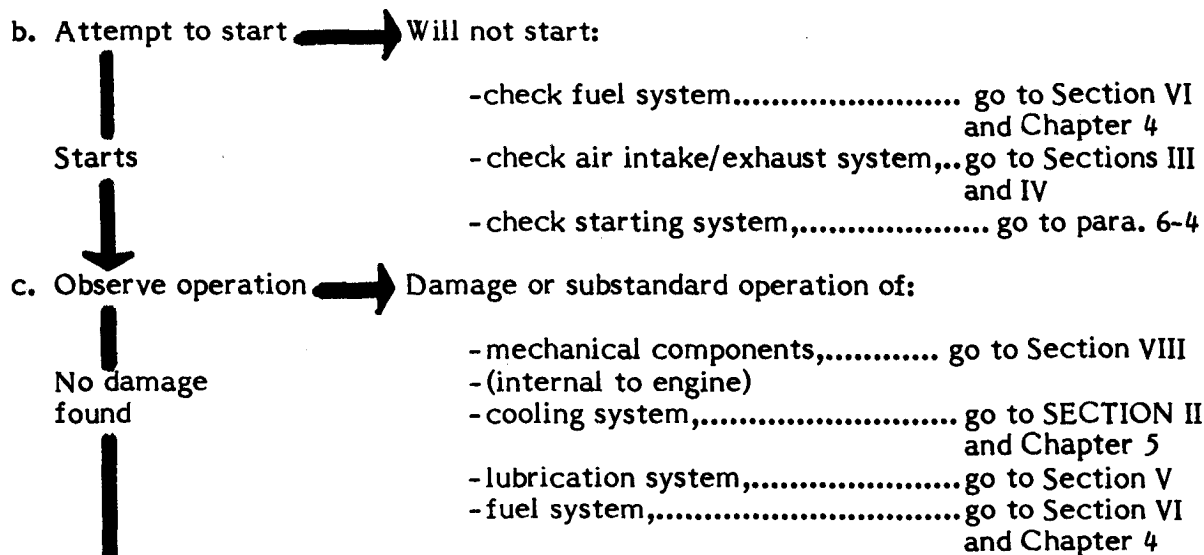

	Engine Assessment			
	Fully Mission Capable	Combat Capable	Combat Emergency Capable	Self Recovery Capable Recover
-Power Output/Response Normal/Near normal	X	X	X	
-Power Output Degraded		X	X	X
-Power Output Severely Degraded			X	X
-No Power				X

3-3. BDAR Procedure Index.

	Para
Engine Malfunctions.....	3-4
Air Cleaner Damaged.....	3-6
Oil Pump Failure.....	3-9
Oil Level Low.....	3-10
Oil Pan Holes.....	3-11
Injector Failure.....	3-13
Throttle Linkage Damaged.....	3-14
Piston, Engine, Perforated Head.....	3-15
Engine/Transmission Housing Damage.....	3-16
Connecting Rod or Rod Bearing Failure.....	3-17

## SECTION II. Engine Failure

### 3-4. ENGINE MALFUNCTIONS

#### General Information

Availability of engines may become restricted to those found in damaged vehicles. Basic engines from other vehicles can be modified or configurations rearranged to fit the vehicle needing the engine. The below listed vehicles all use the 6V 53 series engine. Basic engines are the same but manifolds, exhaust or cooling systems require different brackets to fit a particular vehicle. Accessories and brackets must be swapped from the unserviceable vehicle to make the replacement engine fit another application.

#### Limitations

- None

#### Personnel/Time Required

- 3 soldiers
- 2-4 hours

#### Materials/Tools:

- Lift capability

#### Procedural Steps:

1. Remove power pack.
2. Separate engine from power pack.
3. Inspect and change configuration.
  - a. Mounting brackets.
  - b. Exhaust manifolds.
  - c. Air intake horn engine.
  - d. Engine wiring harness.
4. Reconnect engine to power pack.
5. Reinstall power pack.
6. Check operation to confirm performance adequacy.
7. Record the BDAR action taken. When the mission is completed, as soon as practicable, repair vehicle using standard maintenance procedures.

Systems Utilizing  
6V53 Series Engine :

Piranha, Mowag  
(Swiss Made)  
10,000 R. T. Forklift  
M113 FOV  
GMC 44 Passenger Bus  
LAV, Canadian

### SECTION III. Engine Air Intake System

#### 3-5. General.

The M113 air intake system consists of the air filter and housing, duct tubing, and a roots type blower assembly. The air cleaner has a removable filter element and draws air from the engine compartment. The air is ducted through a spring reinforced fiber tube to the blower air horn. The roots blower pressurizes the air and feeds it to the engine air box.

Restrictions or air leaks will affect the engine operation or durability. Dirt ingestion will cause rapid wear to the engine internal components.

The M113 vehicle air intake system comprises aluminum castings, flexible hose, and aluminum canisters for the air cleaner.

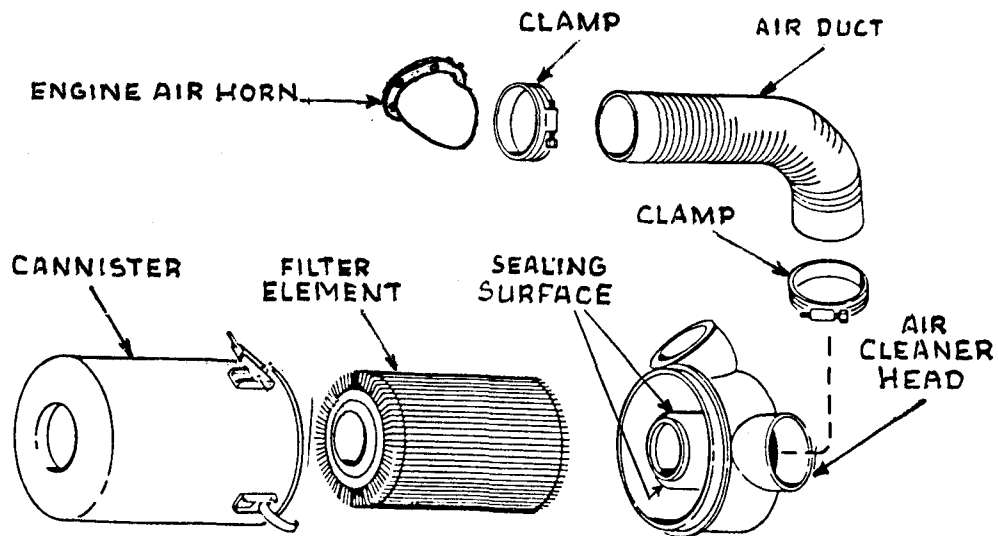

Figure 3-1. Air Intake

#### 3-6. AIR CLEANER DAMAGED

##### General Information

Dirt ingestion into engine caused by damaged air cleaner cannister or hoses. Internal location of air cleaner makes it less likely to incur battle damage. Engine will operate properly without the intake hose and cleaner, if necessary, but air should be drawn from crew compartment to keep as much dirt as possible out of the engine. Unfiltered air will cause dirt ingestion damage.

##### Limitation

- Possible degraded performance

**Personnel/Time Required:**

- 1 soldier
- 15 minutes

**Materials/Tools**

- Clean rag
- Large hose or clamp or wire

**Procedural Steps:**

1. If hole in air cleaner cannister or hose is small enough:

a. Twist the surface of a rag into a point and insert into the hole.

b. Secure the remainder of the rag to prevent suction of the engine pulling the rag into and thru the hole.

2. If hole is too large to stop up as above, or by some other means:

a. Disconnect the air hose from engine.

b. Cover inlet with a clean rag (use shirt if rag is not available).

c. Anchor the cloth tightly with a hose clamp or wire.

3. Record the BDAR action taken. When the mission is completed, as soon as practicable, repair vehicle using standard maintenance procedures.

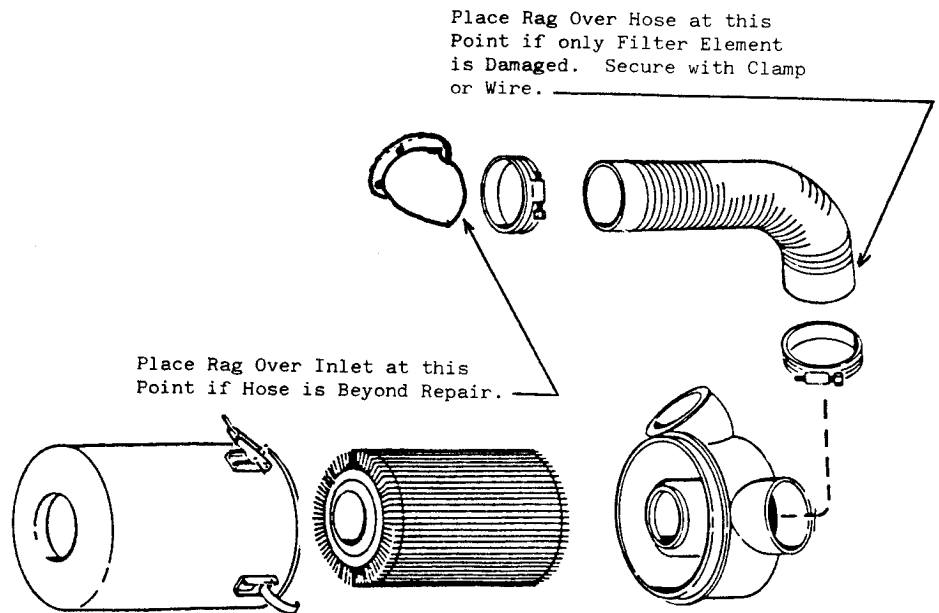

### SECTION IV. Engine Exhaust System

#### 3-7. General.

The engine exhaust system consists of the exhaust manifold, muffler and pipes to route the gases to the muffler and out of the vehicle. Damage to the muffler or pipes are inconvenient but the vehicle can still be operated. Care must be taken, however, to keep carbon monoxide out of the crew compartments. Exhaust manifold repairs and engine compartment seal repairs are covered in TM 9-2350-276-BD.

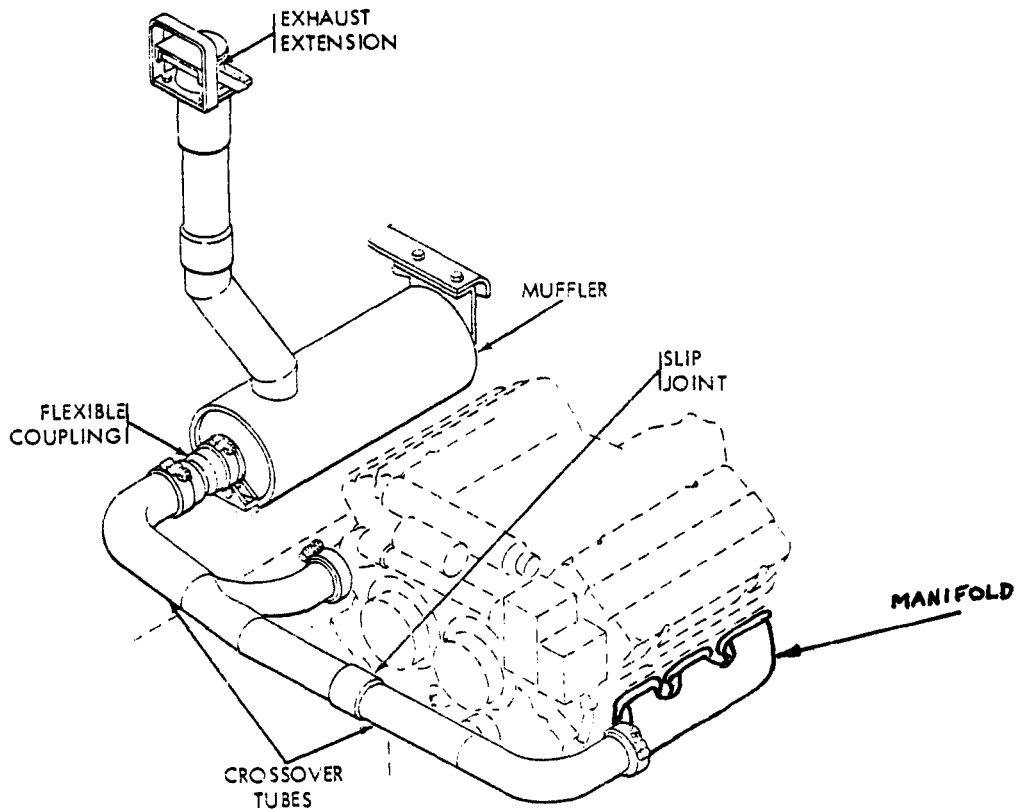

Figure 3-2. Engine Exhaust System



## SECTION V. Engine Lubrication System

### 3-8. General.

The lubrication system consists of an oil intake screen and tube assembly, oil pump, pressure regulator, oil filter, bypass valve, and oil cooler. The rotor type oil pump is bolted to the back of the engine lower front cover and is driven directly by the crankshaft. Lubricating oil is picked up from the oil pan by the pump. From the pump, it passes from the lower front cover through short gallery passages in the cylinder block to the oil filter adapter plate. From the adapter plate, oil flows through the oil filter, and then through the oil cooler, and back into the front engine cover and cylinder block oil galleries for distribution to the various engine bearings. The drain from the cylinder head and other engine parts leads back to the oil pan. Clean engine oil is assured by a replaceable element filter. Should the filter become clogged, oil will flow through a bypass valve in the adapter plate directly to the oil cooler. If the oil cooler becomes clogged, oil will flow directly through a bypass valve in the lower cover to the cylinder block oil galleries. Stabilized oil pressure is maintained at all engine speeds by a regulator valve located in the lower front cover.

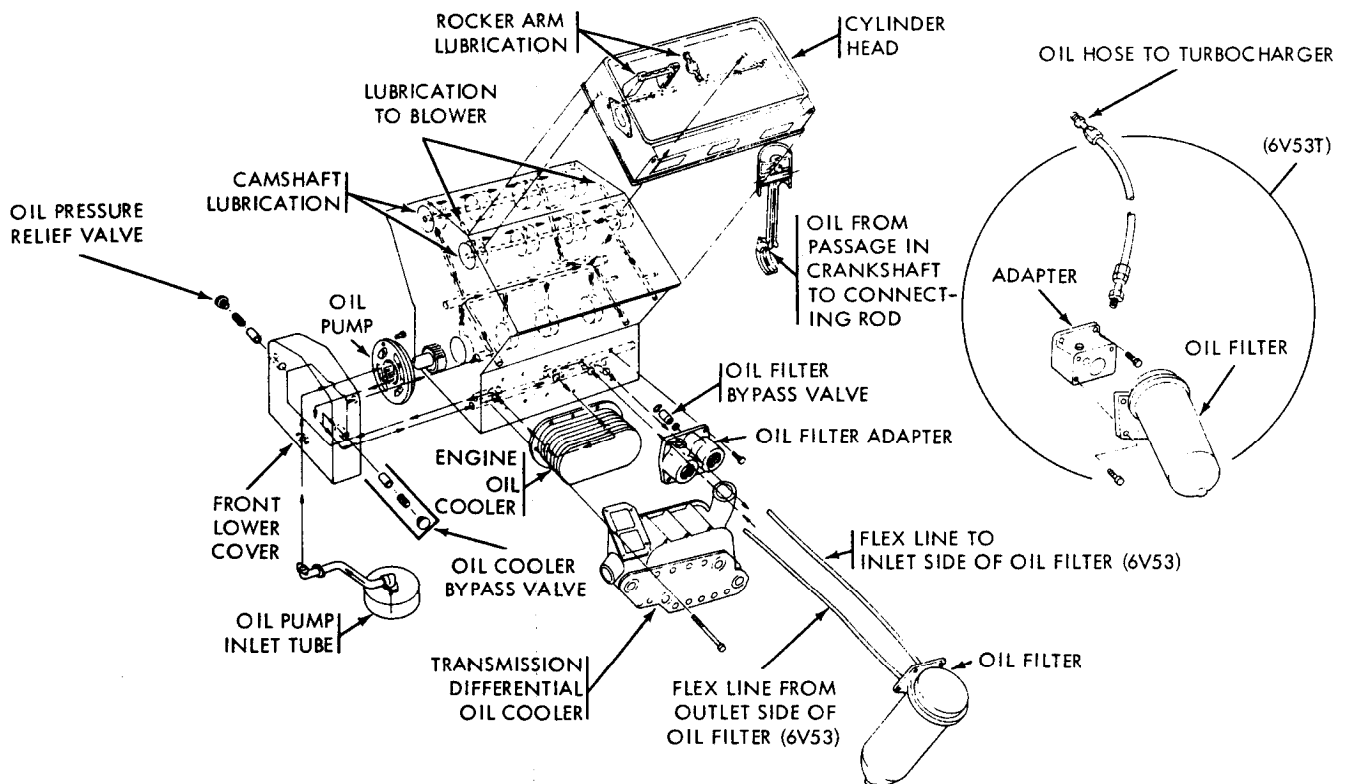

Figure 3-3. Lubrication System Diagram

### **3-9. OIL PUMP FAILURE**

#### **General Information**

Oil pump fails to supply sufficient lubricant to the engine. The suggested solution will provide limited lubrication of the main and rod bearings, however, the rocker arm bearings, push rod clevis bearings, camshaft bearings and cam followers will not receive any lubrication. The wrist pins, piston skirts and cylinder walls will receive minimum lubrication. During a past modification to the camshaft journal oil openings, failure to increase oil pump capacity caused engine failure because of galling of the cylinder liners during dynamometer testing. Of more importance, perhaps, is the lack of lubrication for blower and the idler gear bearings. Early failure of the blower will occur without proper oil pump operation. This procedure should only be used as a last resort.

#### **Limitations:**

- Severe mobility restrictions

#### **Personnel/Time Required**

- 1 soldier
- 10 minutes

#### **Materials/Tools:**

- Oil

#### **Procedural Steps:**

1. Check for broken oil lines or cooler.
2. Overfill engine with any available motor or gear oil. This will provide a limited splash system in the crankcase to lubricate bearings and cylinder walls.
3. Record the BDAR action taken. When the mission is completed, as soon as practicable, repair the vehicle using standard maintenance procedures.

### **3-10. OIL PAN HOLES**

#### **General Information**

Repair of oil pan leakage due to cracks or holes can be attempted without removing the power pack. If the oil pan leak is inaccessible, remove the power pack to repair.

#### **Limitations:**

- None

**Personnel/Time Required:**

- 1-3 soldiers
- 1-3 hours

**Materials/Tools:**

- Cleaning solvent
- Rags
- Hardening sealer
- Non-hardening sealer

**Procedural Steps:**

1. Remove power pack, if required.
2. Clean area around holes or cracks and fill them with non-hardening silicone sealant, Permatex II, or any metal filler available.

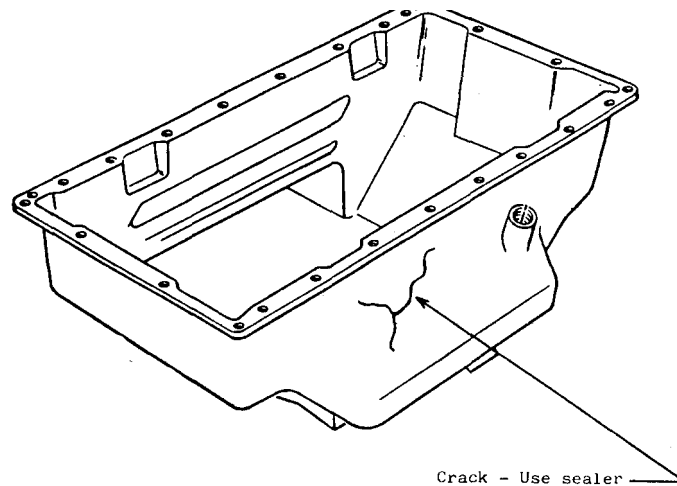

3. If hole is too large to be filled, make a wooden peg, cover outside of peg with sealer, and place into the hole.

**Procedural Steps (Cont):**

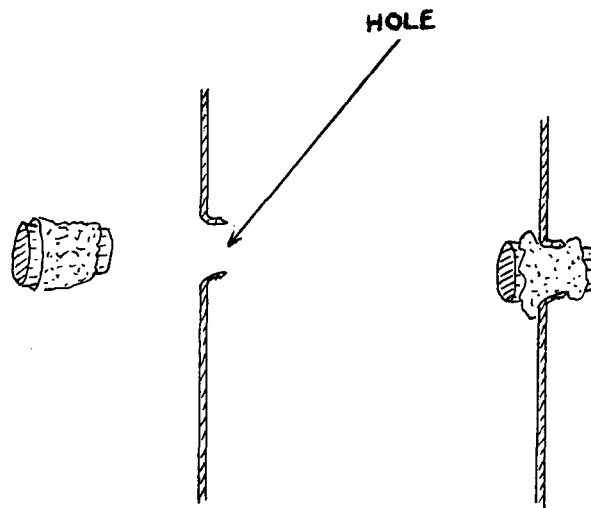

4. Refill crankcase to proper oil level.

5. Record the BDAR action taken. When the mission is completed, as soon as practicable, repair the vehicle using standard maintenance procedures.

**3-10. OIL LEVEL LOW**

**General Information**

Insufficient engine lubrication will occur if the oil level is low. Loss of oil can occur by the engine burning it or by damaged or ruptured filters, oil cooler and lines. The cause of oil loss must be repaired or eliminated prior to adding oil or substitutes. Appendix C lists oil substitutes which are acceptable for longer time periods. Other sources are:

- a. Damaged engines from other vehicles.
- b. Used oil.
- c. Diesel fuel, not to exceed 50 percent (approximately two gallons).
- d. Gear oil, diluted with diesel to lower the viscosity.
- e. Any petroleum based brake or hydraulic fluids.

Care must be taken when using a non-standard oil substitute. The lubricating quality is greatly reduced resulting in engine life being considerably shorter. As soon as the proper oil is available the oil filters and crankcase must be serviced.

## SECTION VI. Engine Fuel System

### 3-12. General.

The engine fuel system provides the pressurized fuel needed for proper operation of the compression ignition engine. An engine mounted mechanical fuel pump provides fuel to the fuel injectors which inject fuel into the cylinder in the proper quantities. The fuel injectors are cam-operated by pushrods and a rocker arm arrangement to provide fuel injection at the proper time.

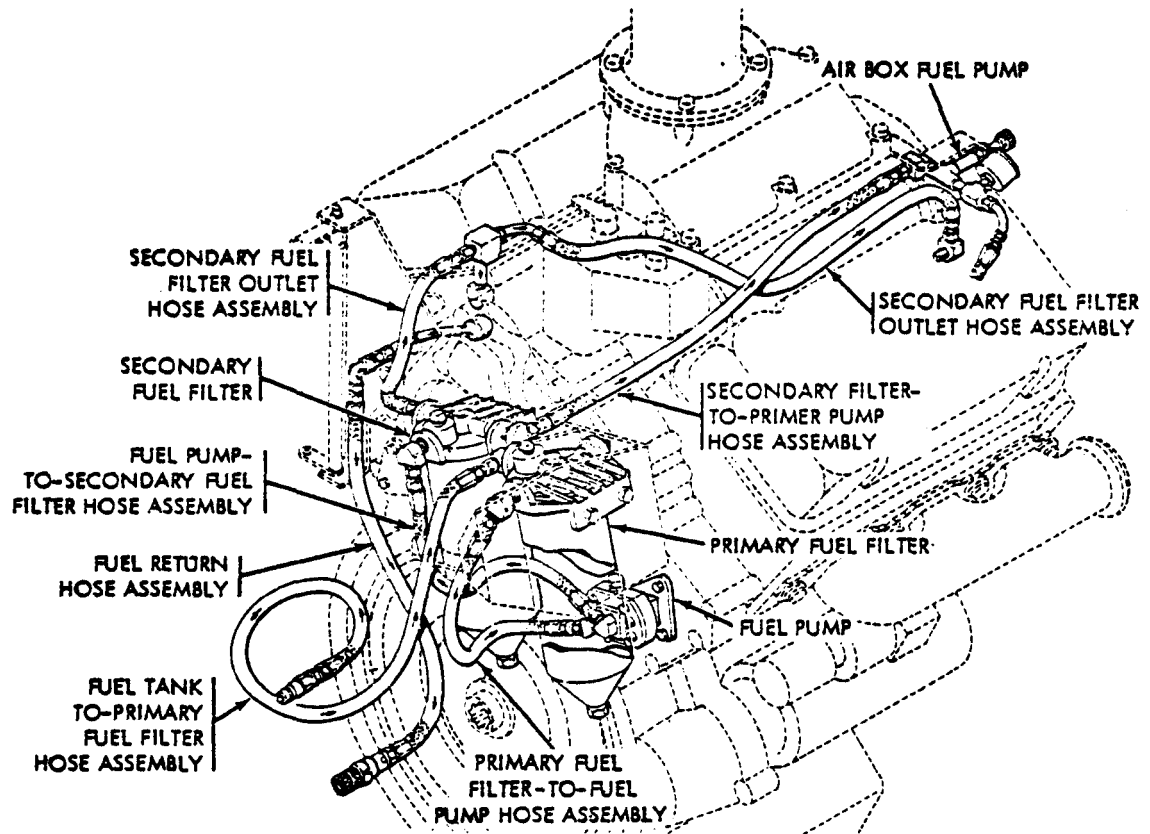

Figure 3-4. Engine Fuel System

### 3-13. INJECTOR FAILURE

#### General.

Fuel injector failure should be noticeable through a loss of power or excessive smoke. Within the Detroit Diesel family of engines the injectors are physically interchangeable although their operating characteristics differ for the engine configuration they are designed for. Injectors should be exchanged, if possible, in full sets to keep engine operation balanced between cylinders. Single replacement is, however, possible. The defective injector can be located by following this procedure.

**Procedural Steps:**

1. Remove valve covers.
2. Start engine.
3. Press firmly on injector guide follower of each injector.
4. Listen for a change in engine operation.  
If a change is noticed, the injector is functioning.
5. If no change in engine operation is noticed, the injector is not functioning.
6. Change defective injector at cylinder with an available injector.

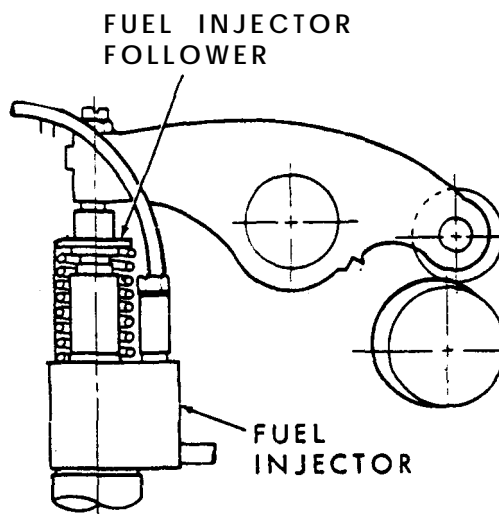

<u>ENGINE TYPE</u>	<u>INJECTOR</u>	<u>USED IN</u>
3-53		Gamma Goat
4-53		Commercial vehicles
6V-53	M-50	M113 FOV, Commercial, R.T.
6V-53T	N-70	Forklifts
8V-71		M551 Sherridan
8V-71T	S-80 Crown Type N-80 Needle Type	Power generation S. P. Howitzer, M578 Recovery Vehicle

**3-14. THROTTLE LINKAGE DAMAGED**

**General Information**

Inability to govern power plant controls will degrade the mobility of the vehicle. The hand throttle cable will provide an immediate move capability, but a more responsive throttle control is possible using this procedure.

**Limitation**

- Degraded mobility

**Personnel/Time Required:**

- 1-2 soldier
- 15 minutes

**Materials/Tools:**

- Commo wire
- Wire cable
- Wire
- Spring
- Blousing aid

**Other Options:**

- Use commo wire, wire cable, or any other type of still wire to tie throttle or any
- ther linkage in the desired position.
- Use a stiff wire like welding rod to move the fuel control arm.

**Procedural Steps**

1. Remove engine access panel in the driver's compartment.
2. Remove defective mechanical linkage to fuel control at the engine.
3. Tie wire, commo or other available wire, to the fuel control on the engine.
4. Connect a spring or rubber device to return the fuel control to the idle position.
5. Route the wire so the operator or crew member can control acceleration by pulling or releasing the wire control.
6. Record the BDAR action taken. When the mission is completed, as soon as practicable, repair the vehicle using standard maintenance procedures.

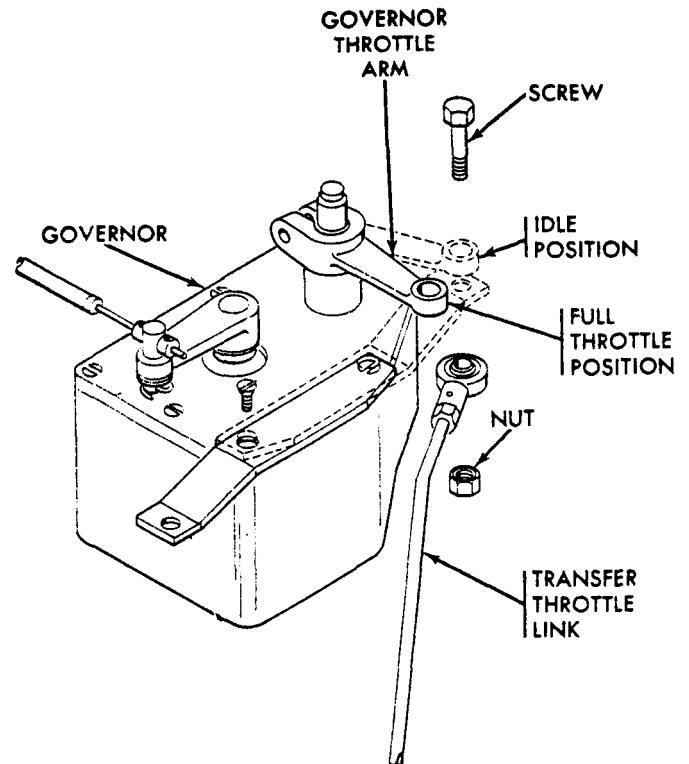

## **SECTION VII. Engine Structure/Internal Components**

### **3-15. PISTON, ENGINE, PERFORATED HEAD**

#### **General Information**

Loss of engine power because of hole in piston head. For brief periods of operation it is unnecessary to take any corrective action. For extended operation it is necessary only to disable the fuel injector of the cylinder with the bad piston. The problem arises in identifying the cylinder. The value of compression is not important, only enough to ensure that there is no hole in the piston. While engine is still in the vehicle, check each cylinder using the following procedure:

#### **Limitations:**

- Degraded mobility

#### **Personnel/Time Required:**

- 2 soldiers
- 2 hours

#### **Other Options:**

- Defer repairs

#### **Procedural Steps:**

1. Remove one rocker arm cover.
2. Start engine.
3. Press firmly on injector guide follower of each injector.
4. Listen for a change in engine operation. If a change is noticed, the cylinder is functional.
5. If a change is not noticed, the cylinder is not functioning.
6. Verify the injector is functioning by swapping with another injector.
7. If injector is functional, readjust fuel rack to a "no-fuel" position at the defective cylinder.
8. Record the BDAR action taken. When the mission is complete, as soon as practicable, repair the vehicle using standard maintenance procedures.



### 3-16. ENGINE/TRANSMISSION HOUSING DAMAGE

#### General Information

**Cracks** or small holes in engine block or transmission housings. In most cases the power pack will need to be removed so that the crack will be accessible. A point to remember is that welding does not have to meet specifications, only hold temporarily. Some general procedures for crack repair, in order of preference are: welding, brazing, epoxy or hard fillers, and soft adhesive/fillers. Use of the below procedures are dependent upon the part to be repaired.

#### Limitations

- None

#### Personnel/Time Required

- 3 soldiers
- 3 to 6 hours

#### Materials/Tools:

- Lift capability
- Arc welding equipment
- Metal filler/sealer

#### Other Options

- Repair of small cracks not causing large amounts of fluid loss may be deferred.

#### Procedural Steps:

1. The engine block is cast iron and may be welded if care is taken not to warp surfaces.
  - a. (Oil soaked, cast iron defects), MIL-E-13191, Type CuSn-A, Type CuSn-C or equivalent.
  - b. Use rod AST-MA 398-65T, Type ENICA ENIFE-C 1 (Engine blocks - water jacket), or equivalent.
2. Cracks into the cooling jacket can be repaired using an epoxy or hardening sealer.
3. Low stress areas such as the air box, may use almost any type of filler/adhesive.
4. The transmission housing is cast aluminum and may be welded if care is taken. Use type 5356, C1, MIL-E-16053 welding wire equivalent. Any of the above fillers/adhesives may be used to repair cracks or holes.
5. The steel oil pans of the engine and transmission can be welded. Any fiberglass kit may be used.

**TM 9-2350-275-BD  
ENGINE**

**Procedural Steps (Cont):**

6. The steer control differential is made from a magnesium alloy. Use plastic type fillers or appropriate MIG or TIG welding equipment to make repairs.
7. Record the BDAR action taken. When the mission is completed, as soon as practicable, repair vehicle using standard maintenance procedures.

**3-17. CONNECTING ROD OR ROD BEARING FAILURE**

**General Information:**

Broken connecting rod or rod bearing failure will cause the engine to be inoperative, normally with extensive internal engine damage. If the engine is not damaged where it will no longer run, it may be operated under emergency conditions, using the following procedures. The damaged cylinder can be isolated and continued operation is possible. The lower portion of the connecting rod must be replaced on the crankshaft to maintain oil pressure. Without the rod on the crank journal the oil will free flow from the oil gallery causing excessively low oil pressure with resulting damage to other engine components.

**Limitation**

- Reduced mobility

**Personnel Time/Required:**

- 2 soldiers
- 4-6 hours

**Materials/Tools:**

- Wood wedge
- Engine oil and coolant
- Lifting device

**Procedural Steps:**

1. Remove power pack.
2. Remove oil pan to gain access to connecting rod bearing caps.
3. Remove the lower portion of damaged connecting rod, bearings and bearing cap.

**Procedural Steps (Cont):**

4. Cut rod and re-install the bearing section of rod on the crank to maintain oil pressure.
5. Wedge the piston in cylinder so that the air intake ports are covered.

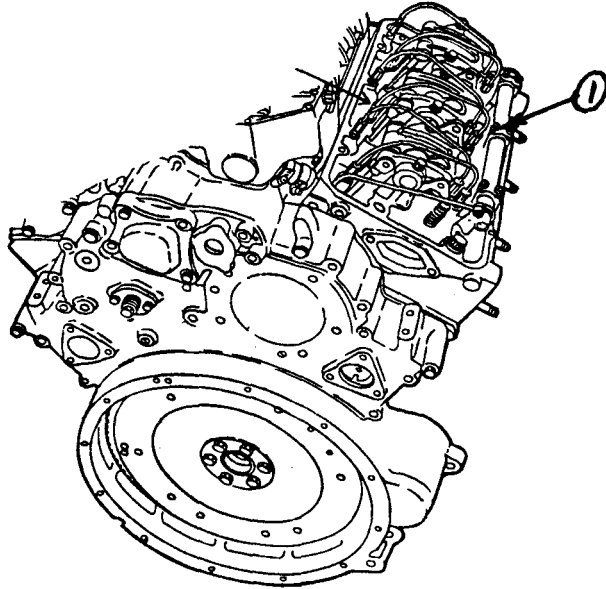

6. Remove valve cover and adjust the fuel rack (item 1) to a no fuel position at the affected fuel injector. This is to prevent unburned fuel from being pumped into the cylinder and through into the crankcase.
7. Replace oil pan, engine oil and valve cover.
8. Reinstall power pack.
9. Record the BDAR action taken. When the mission is completed, as soon as practicable, repair the vehicle using standard maintenance procedures.

CHAPTER 4  
FUEL SUPPLY SYSTEM

BDAR FIXES SHALL BE USED ONLY IN COMBAT  
AT THE DISCRETION OF THE COMMANDER  
AND SHALL BE REPAIRED BY STANDARD MAINTENANCE PROCEDURES  
AS SOON AS PRACTICABLE AFTER THE MISSION IS COMPLETED.

SECTION I. General

4-1. General.

The fuel is stored in aluminum fuel tanks located in different locations according to vehicle type (see Figures 4-1 through 4-5). The fuel is routed through aluminum and steel fuel lines to a paper element fuel filter and then through steel reinforced rubber hoses to the fuel pump on the engine.

4-2. Assessment Procedure.

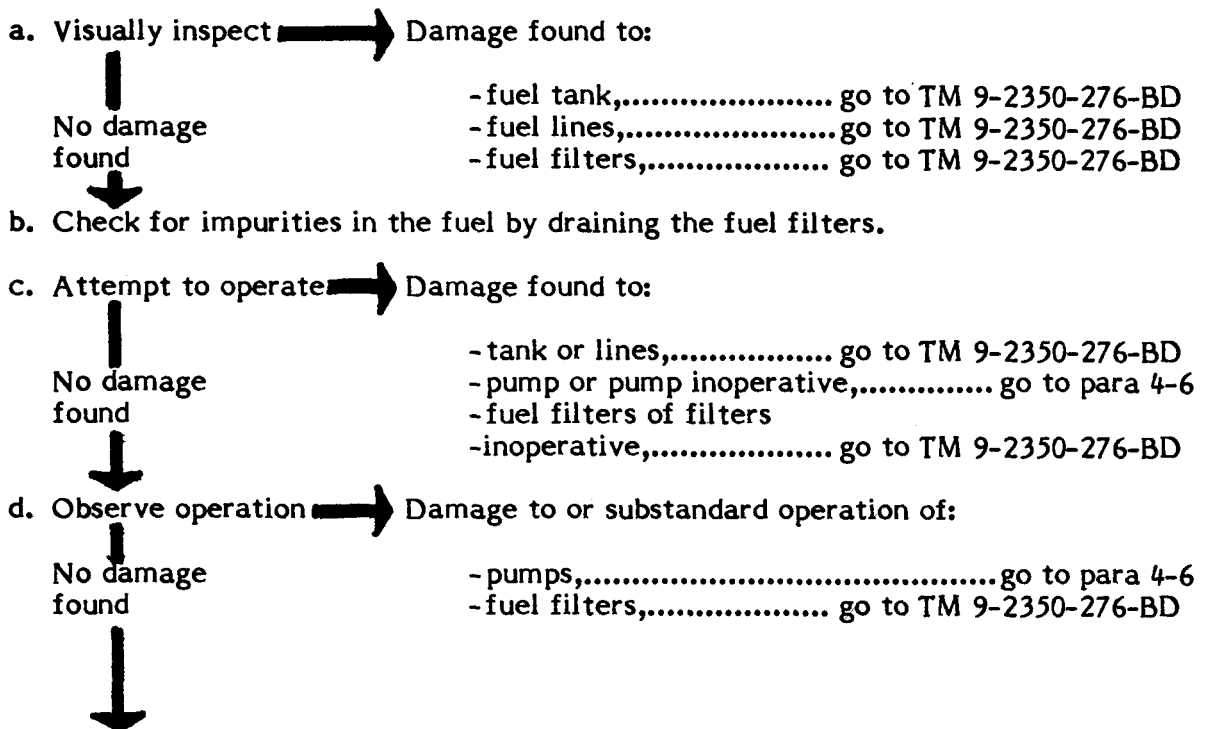



e. Evaluate system performance:

**FUEL SYSTEM ASSESSMENT**

	Fully Mission Capable	Combat Capable	Combat Emergency Capable	Self Recovery Capable	Recover
-Output adequate	X	X	X		
-Output degraded		X	X	X	
-Output severely degraded			X	X	
-No output					X

4-3. BDAR Procedure Index

Para

Fuel Injector Line Rupture ..... 4-5  
 Fuel Pump Interchangeability..... 4-6

## Section II. Fuel Storage Systems

### 4-4. General.

Fuel tank and line repair procedures are covered in TM 9-2350-276-BD. The repairs applied will be determined by the accessibility to the damage.

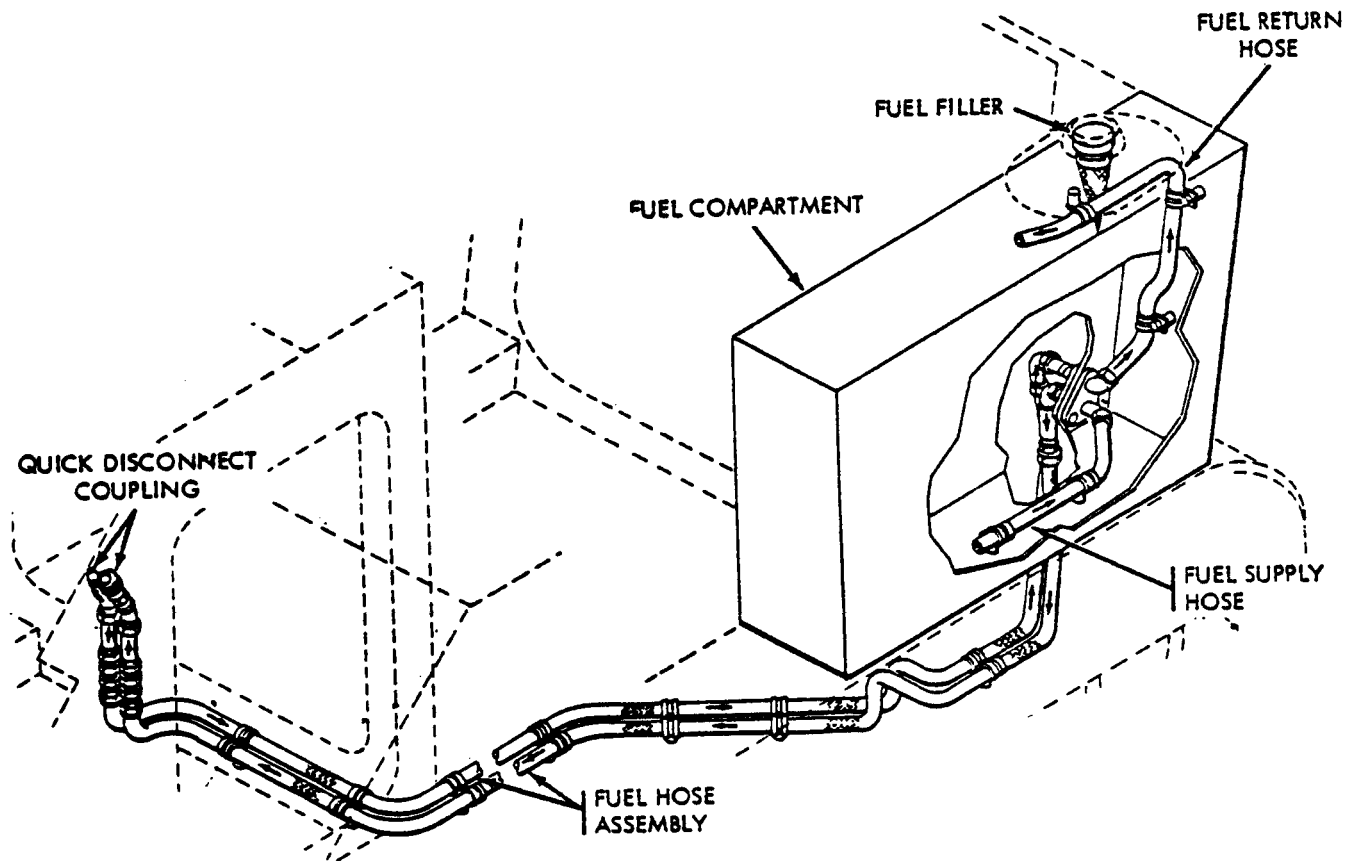

Figure 4-1. Carrier Fuel Storage

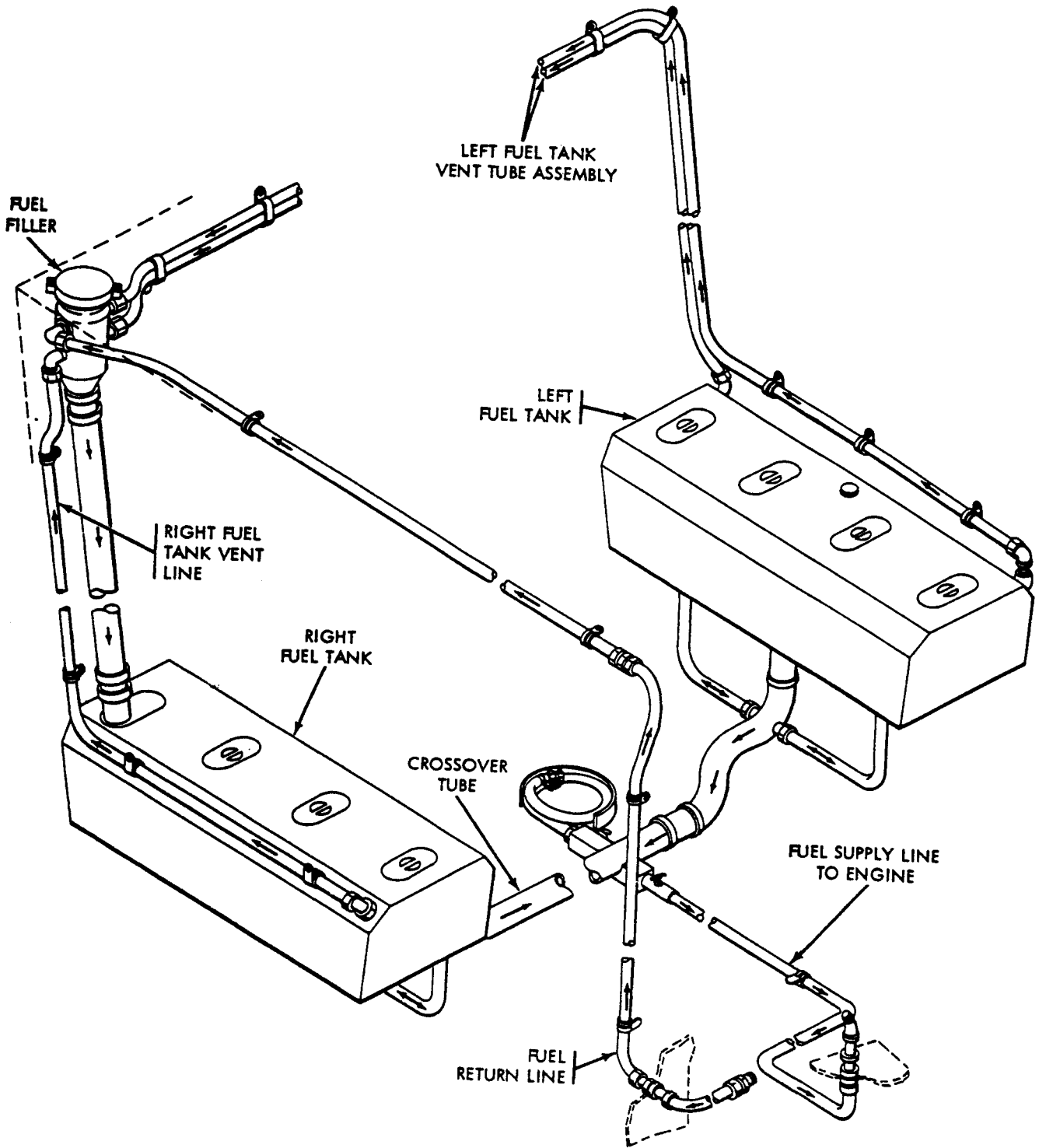

Figure 4-2. M577 Fuel System

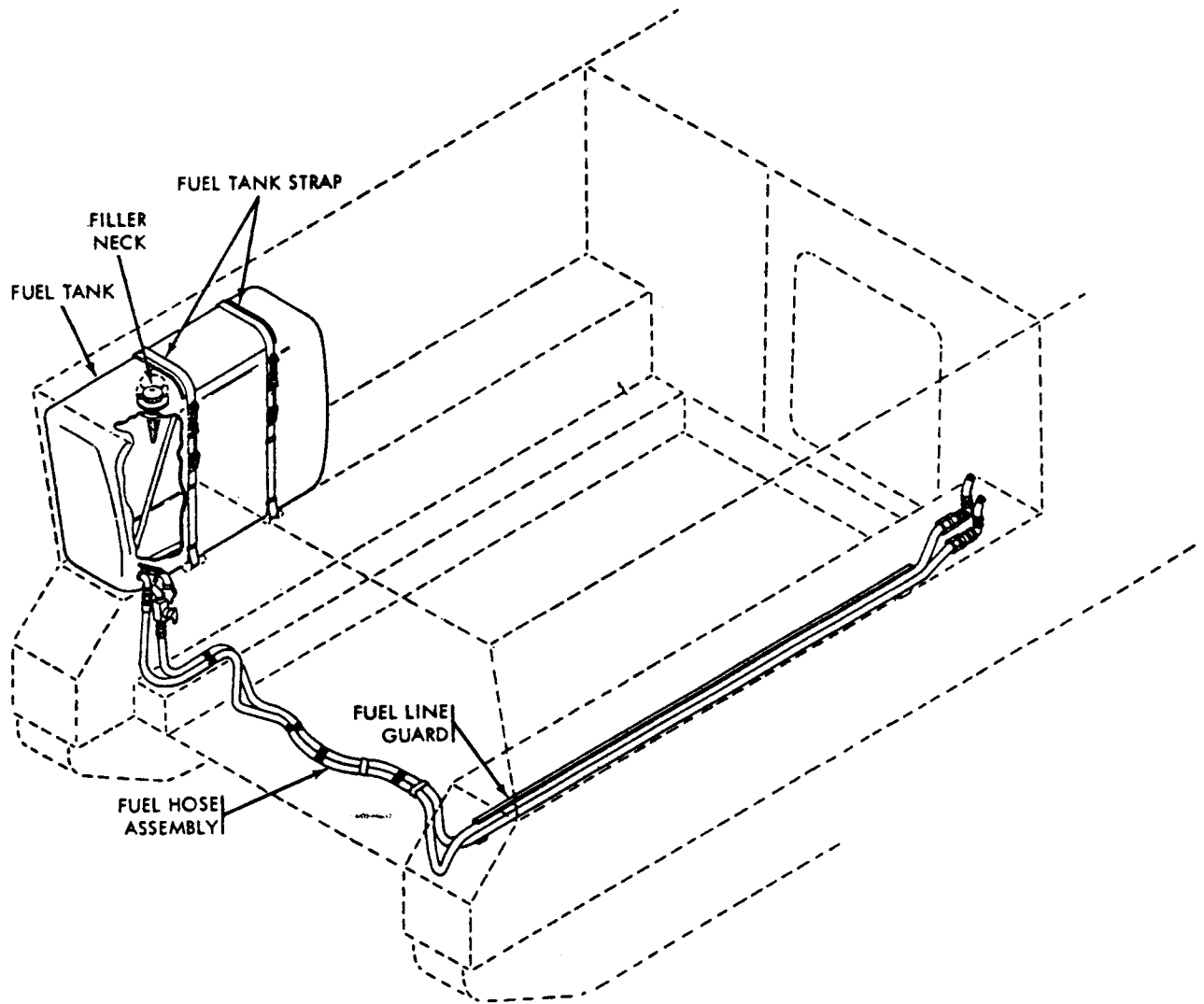

Figure 4-3. Carriers with Bolt-In Fuel Tank



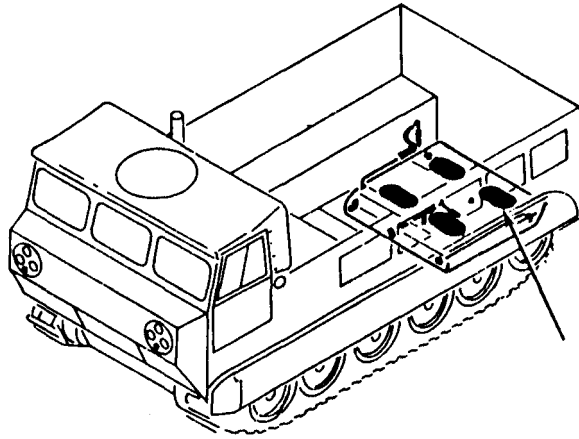

Figure 4-4. M548 and M730 Fuel Tanks

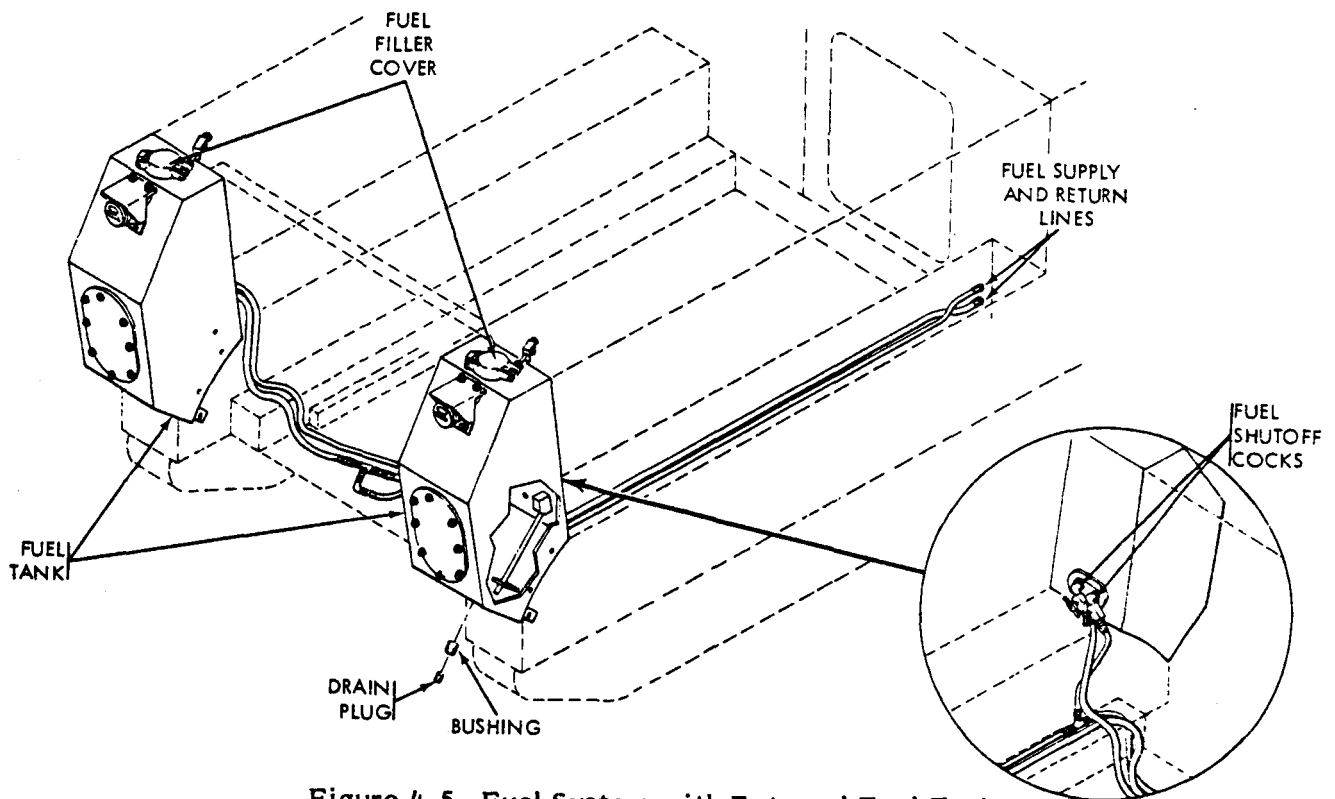

Figure 4-5. Fuel System with External Fuel Tanks

## 4-5. FUEL INJECTOR LINE RUPTURE

### General Information

Failure of an injector can be noticed by a loss of power or increased fuel consumption. If either occurs the injectors and fuel lines should be inspected to determine the cause. If the crankcase oil is overfull or has a diesel odor, remove the valve covers and inspect the fuel lines for cracks. Operate the engine with the valve covers removed to check for fuel leaks. Unrepaired injector lines will cause the fuel to enter the crankcase, diluting the engine oil and resulting in early engine failure.

### Limitations:

- . Reduction of power

### Personnel/Time Required

- 1 soldier
- 1 hour

### Materials/Tools:

- Vice grips

### Other options:

- Crimp the damaged fuel injector line shut.

### Procedural Steps:

1. Gain access to engine compartment.
2. Remove the valve cover of the affected cylinder.
3. Operate engine to determine failed line.
4. Disconnect the leaking line.
5. Bypass the injector by bending the remaining good line and connecting the inlet and outlet together.

**TM 9-2350-275-BD  
FUEL SUPPLY SYSTEM**

**Procedural Steps (Cont):**

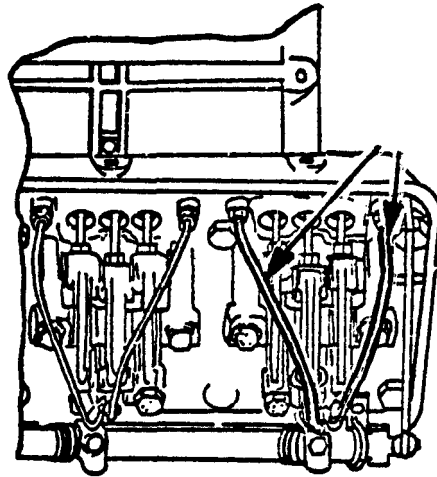

6. Back off the injector rocker adjustment to prevent damage to the injector.
7. Adjust the fuel injector rack to a no fuel position at the injector.
8. Reinstall the valve covers.
9. Record the BDAR taken. When the mission is completed, as soon as practicable, repair vehicle using standard maintenance procedures.

**4-7. FUEL PUMP INTERCHANGEABILITY**

**General Information**

The fuel pumps used on the M113 FOV are used on other similar vehicles and can be cannibalized from US or foreign owned equipment. Fuel pumps from other Detroit Diesel engines can be substituted. Stock numbers and part numbers may differ **but** these items will interchange with the following vehicles M 107, M 108, M 110, M578, M975 and Pershing.

1. Engine Driven Rotary Fuel Pump
2. Personnel Heater Electric Fuel Pump
3. Air Box Heater Rotary Fuel Pump
4. Engine Coolant Heater Electric Fuel Pump (Winterization Kit)

## CHAPTER 5 COOLING SYSTEM

BDAR FIXES SHALL BE USED ONLY IN COMBAT  
AT THE DISCRETION OF THE COMMANDER  
AND SHALL BE REPAIRED BY STANDARD MAINTENANCE PROCEDURES  
AS SOON AS PRACTICABLE AFTER THE MISSION IS COMPLETED.

### SECTION I. General

#### 5-1. General.

Cooling system problems maybe indicated by a variety of faults. Typically the driver's indicator panel will show overheating.

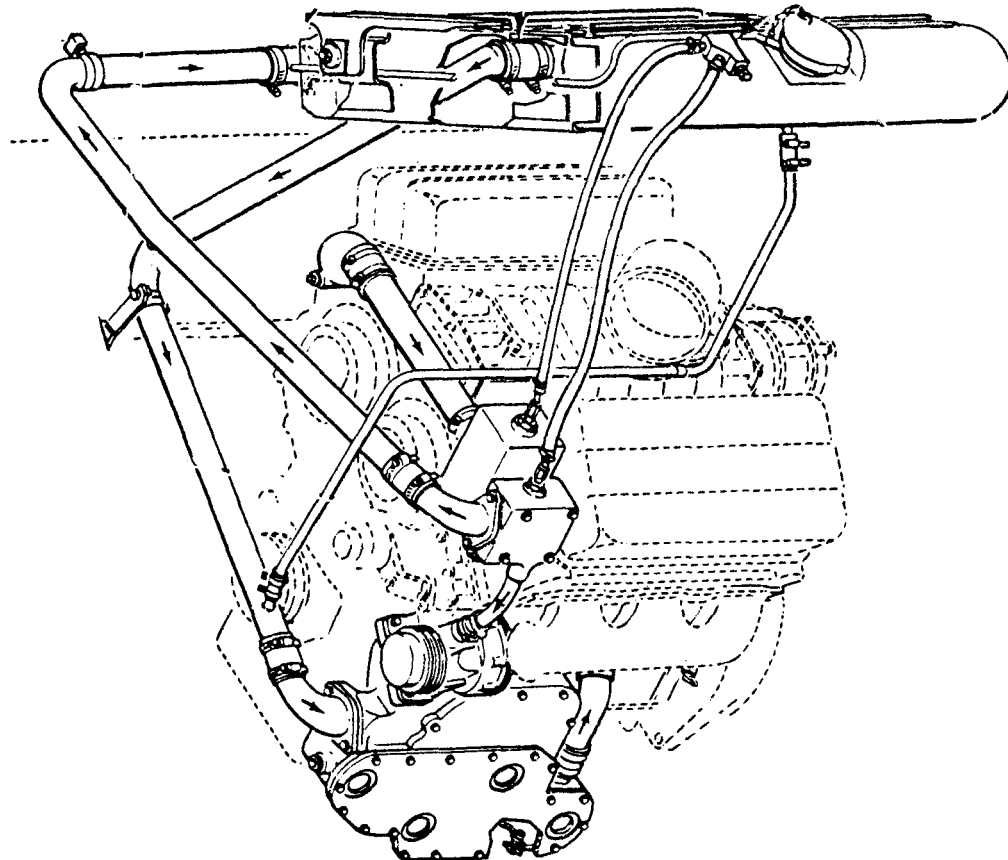
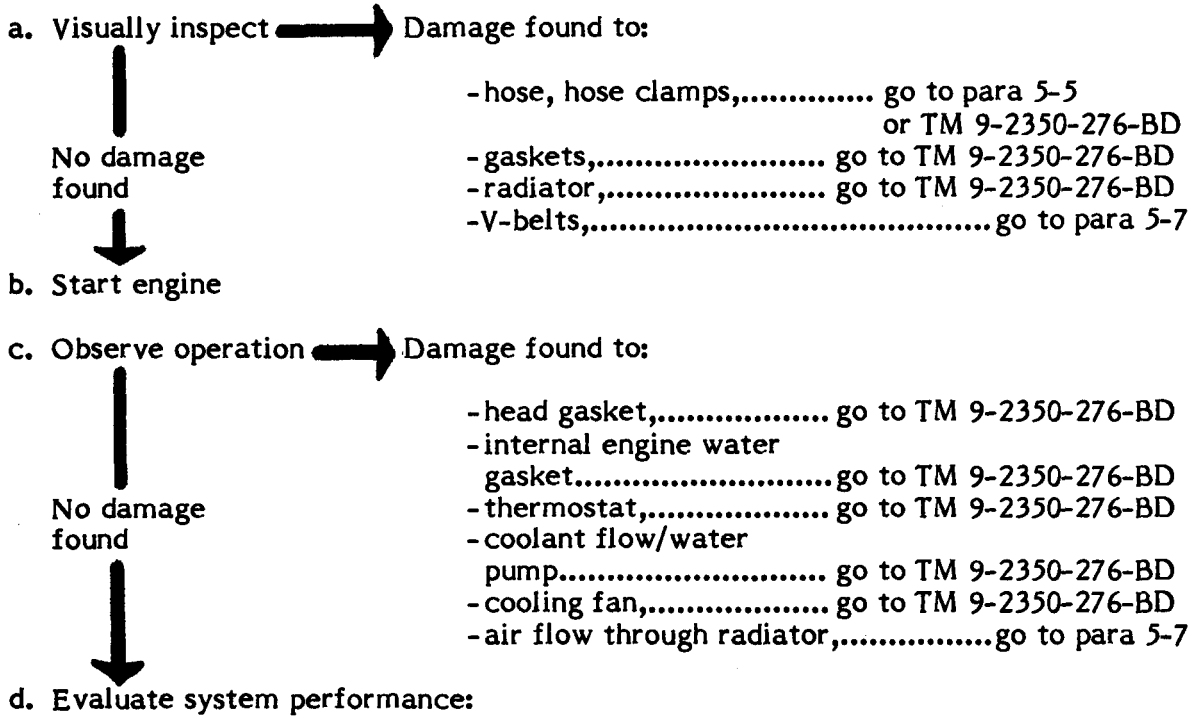

Figure 5-1. Coolant Flow

5-2. Assessment Procedure



	Cooling System Assessment			
	Fully Mission Capable	Combat Capable	Combat Emergency Capable	Self-Recovery Capable Recover
- Cooling normal/near normal	X	X	X	
- Cooling degraded		X	X	X
- Cooling severely degraded		X <sup>1</sup>	X <sup>1</sup>	X <sup>1</sup>
- No cooling			X <sup>1</sup>	X <sup>1</sup>

Note 1  
<sup>1</sup>Careful operation under these conditions will not damage the engine if it is operated only to reposition or move the vehicle under light acceleration for short periods of time. The engine oil temperature must be allowed to cool between operations.

5-3. BDAR Procedure Index

Para

Metal Tubing Damaged.....	5-5
Coolant Frozen.....	5-6
V-Belt, Missing or Broken.....	5-7

## SECTION II. Cooling System BDAR

### 5-4. General.

This section describes several procedures which can be used to restore cooling capacity to the vehicle. Other BDAR expedients are given in TM 9-2350-276-BD

### 5-5. METAL TUBE DAMAGED

#### General Information:

Loss of cooling fluid due to defective hose, resulting in engine overheating. When replacement is necessary, and the correct size is not available, a temporary repair may be made by using the 2-1/2 inch in diameter by 4-1/2 inch long hose coupline used throughout the cooling system.

#### Limitations:

- None

#### Personnel/Time Required

- 1 soldier
- 20-30 minutes

#### Materials/Tools:

- Bulk hose, 2-1/2 inch inside diameter
- Hose clamps
- Hacksaw

#### Other Options:

- Refer to TM 9-2350-276-BD

#### Procedural Steps:

1. Cut out a section of the vehicle tube containing the defect.
2. Replace it with the hose coupling. Bulk hose of 2-1/2 inch in diameter may be used for longer lengths.
3. Use hose clamps or improvised clamps to tighten splice.

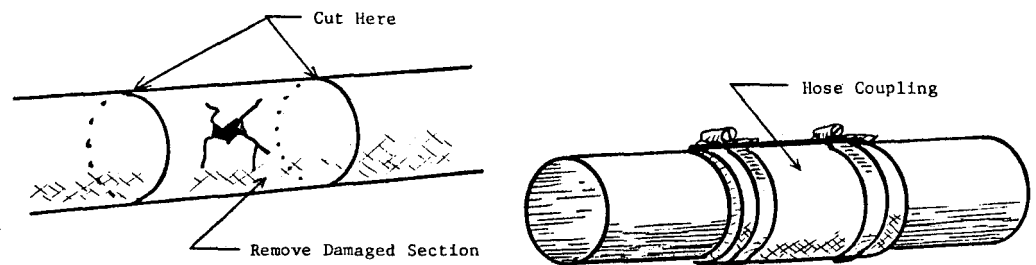

**TM 9-2350-275-BD  
COOLING SYSTEM**

**Procedural Steps (Cont):**

4. Record the BDAR action taken. When the mission is completed, as soon as practicable, repair the vehicle using standard maintenance procedures.

**5-6. COOLANT FROZEN**

**General Information**

The radiator may freeze-up if no antifreeze is available. When vehicle must be driven in freezing weather without antifreeze, remove fan belts until the system gets hot, and cover radiator to reduce air flow to maintain operating temperature. Coolant must be drained or keep the engine operating to prevent the coolant from refreezing.

**Limitations**

- None

**Personnel/Time Required:**

- 1 soldier
- 10-15 minutes

**Other Options:**

- Use personnel heater.
- Use other vehicle's exhaust heat to melt frozen ice.
- Use alcohol if other antifreeze is not available.

**Procedural Steps:**

1. Gain access to engine compartment.
2. Disconnect fan tower belts.
3. Start engine and check water pump belt.
  - a. If pump is turning, go to step 6.
  - b. If pump is not turning stop engine.
  - c. Remove waterpump belt and restart engine.
4. Let engine run for 3 to 5 minutes.
5. Stop engine and re-install water pump belt, if required.
6. Check radiator for ice.
7. Continue steps 3 through 6 until coolant is liquid.

**Procedural Steps (Cont):**

8. Re-install fan tower belts.
9. Close engine compartment panels.
10. Record the BDAR action taken. When the mission is completed, as soon as practicable, repair the vehicle using standard maintenance procedures.

**5-7. V-BELT, MISSING OR BROKEN**

**General Information:**

Vehicle cooling and charging systems inoperable due to missing or broken V-belts.

**Limitations:**

- None
- If rope or wire is used, check tension frequently

**Personnel/Time Required:**

- 1 soldier
- 10 to 60 minutes

**Materials/Tools:**

- Adjustable link belting
- Rope, 3/8 inch to 1/2 inch
- Communication wire

**Other Options**

- For multibelt systems, use one belt from a comparable vehicle

**Procedural Steps:**

**Option 1. Adjustable Link Belt.**

1. Loosen belt adjustment to allow for smallest possible belt length.
2. Assemble belt links to obtain a belt length as close as possible to the original belt length. Care must be exercised that the belt be put on with the belt taper going in the direction of pny rotation. This prevents undue strain on the belt links.
3. Readjust belt tensioner.



**TM 9-2350-275-BD  
COOLING SYSTEM**

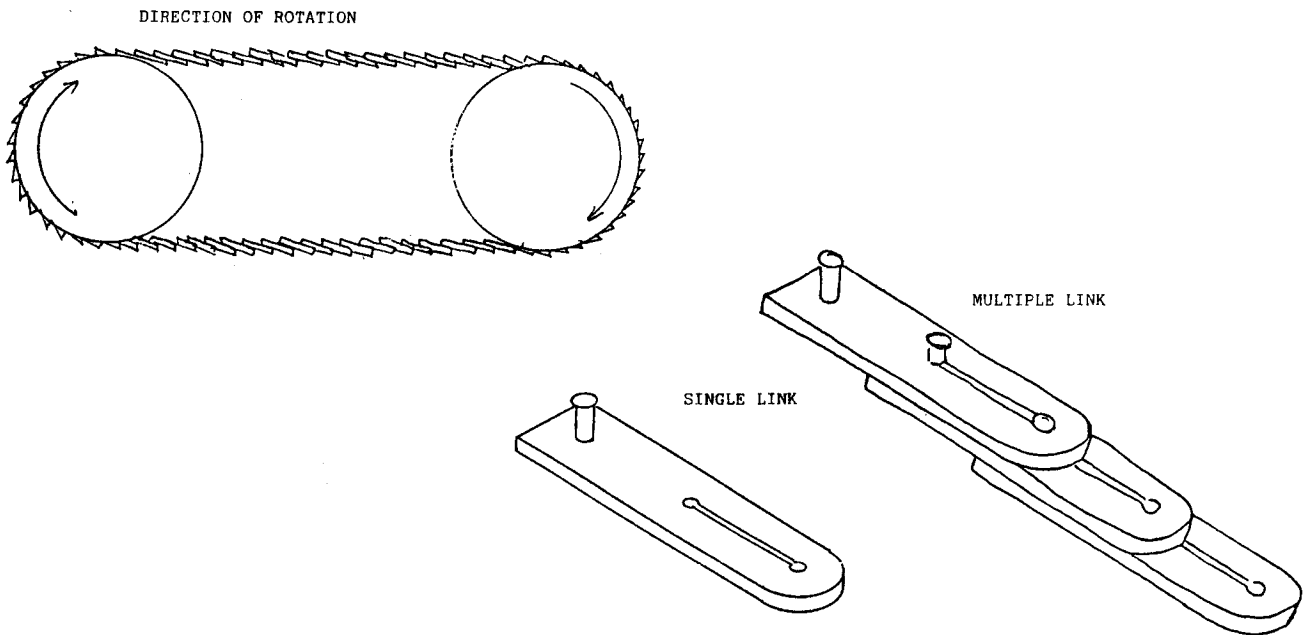

**Option 2.** Rope or wire.

1. Loosen belt adjustment to allow for smallest possible belt length.
2. A rope may be spliced into a loop provided it is stranded rather than woven. Communication wire can also be used. If wire is used, braid three strands together to improve durability.
3. Adjust the belt tensioner.

Record the BDAR action taken. When the mission is completed, as soon as practicable, repair the vehicle using standard maintenance procedures.

REGULAR BELT DATA

<u>Belt</u>	<u>Size</u>	<u>Vehicle</u>
Water Pump	3/8" x 37"	All M113 FOV
Generator	1/2" x 54"	All but M548A1 and M730
	1/2" x 65"	M548A1 and M730
Cooling Fan (two sets)	1/2" x 74"	All but M548A1 and M730
	1/2" x 65"	M548A1 and M730

ADJUSTABLE LINK BELT DATA

<u>Size</u>	<u>NSN</u>
A, 1/2" W.	3030-00-224-8358
O, 3/8" W.	3030-00-427-0535

CHAPTER 6  
ELECTRICAL SYSTEM

BDAR FIXES SHALL BE USED ONLY IN COMBAT  
AT THE DISCRETION OF THE COMMANDER  
AND SHALL BE REPAIRED BY STANDARD MAINTENANCE PROCEDURES  
AS SOON AS PRACTICABLE AFTER THE MISSION IS COMPLETED.

**SECTION I. General**

**6-1. General.**

The electrical system is a 24-volt direct current power supply. Storage is provided by batteries located to the rear of the vehicle. Recharging is provided by an air cooled AC generator. A slave receptacle is provided for emergency power should the vehicle's power fail. The starter is a 24 vDC electric motor protected by a neutral safety switch which prevents starter operation unless the transmission is in neutral. Circuit protection is provided by circuit breakers. When tripped, the circuit breakers will automatically reset as they cool down.

**6-2. Assessment Procedure**

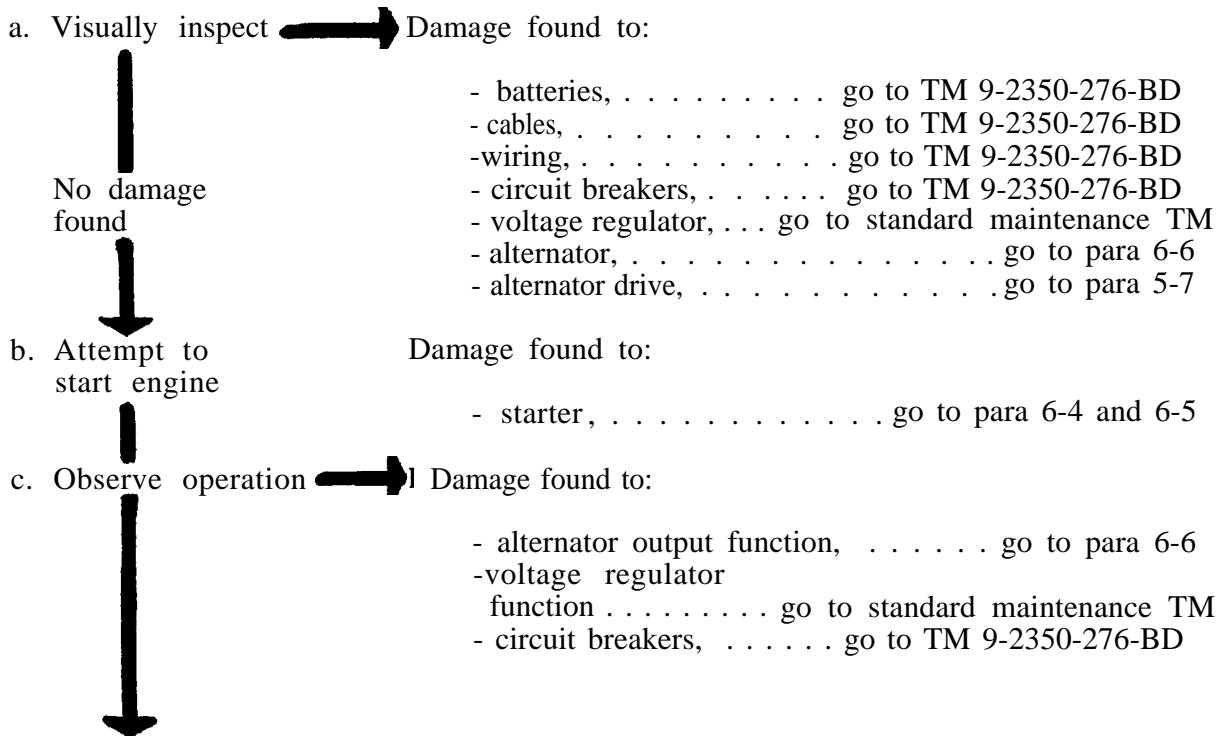



d. Evaluate system performance:

**Charging System Assessment**

	Fully Mission Capable	Combat Capable	Combat Emergency Capable	Self Recovery Capable	Recover
-Charging system works ok	X	X	X		
-Charging system works marginally		X	X	X	
-Charging system does not work		X	X	X	X

6-3. BDAR Procedure Index

	Para
Starter Failure.....	6-5
Neutral Safety Switch Defective.....	6 - 6
Generator Field Safety Switch Defective.....	6-7

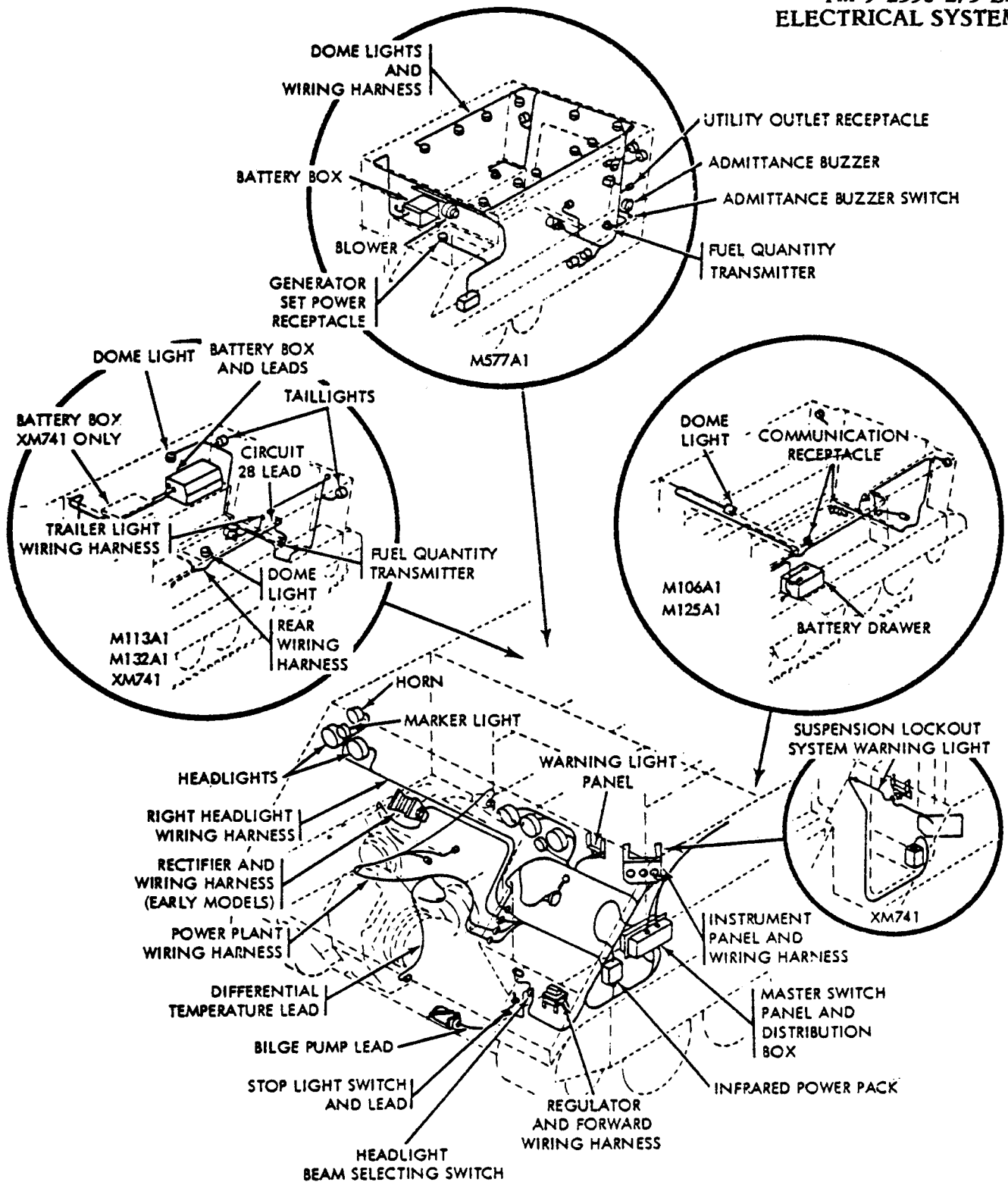

Figure 6-1. Carriers Electrical System

## SECTION II. Electrical BDAR

### 6-4. General.

This section gives procedures to correct electrical faults. Other electrical BDAR expedients are given in TM 9-2350-276-BD.

### 6-5. STARTER FAILURE

#### General Information

Starter will not operate when an attempt is made to start engine. If available, replace the bad starter with one from any other 6V53 or 6V53T engine. All M113 family of vehicles, and some commercial vehicles, are sources for the starter. This procedure will not work on Leece-Neville starters. If starter is good but solenoid will not engage, it may be engaged manually, if the starter is Delco Remy or Prestolite.

#### Limitation

- None

#### Personnel/Time Required

- 2 soldiers
- 15-25 minutes

#### Materials/Tools

- Long screwdriver
- Stick

#### Procedural Steps:

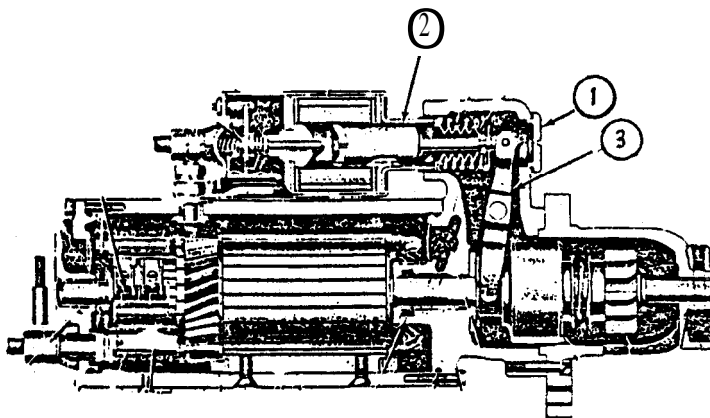

1. Remove the inspection plug (1) from the end of the solenoid (shift lever housing).
2. Use a screwdriver or anything small enough to enter the inspection hole, push inward on the top of the shift lever connected to the solenoid plunger (2), top end of shift lever (3). This will engage the starter drive piston and energize the starter.
3. In case of a starter relay (only found on older vehicles not yet converted), the relay may be by-passed while the engine is being started.

**Procedural Steps (Cont):**

4. Record the BDAR action taken. When the mission is completed, as soon as practicable, repair the vehicle using standard maintenance procedures.

**6-6. NEUTRAL SAFETY SWITCH DEFECTIVE**

**General Information**

Engine starter will not operate because of faulty neutral safety switch. By-passing the neutral safety switch allows the starter to work while the transmission is in gear. For safety, disconnect the cable ends after the engine is started.

**Limitations:**

Ž Engine will start while in gear

**Personnel/Time Required**

- 1 soldier
- 5 minutes

**Materials/Tools:**

- None

**Procedural Steps:**

1. By-pass the neutral safety switch by disconnecting circuits 74 and 74A (circuit 74 and 14 for M741) at the transmission range selector.
2. Connect the 74 and 74A (14 and 74). There will be a male and female pair to allow quick connection. These circuits are found leading to the transmission range selector housing.
- 3 Start the engine.
4. Record the BDAR action taken. When the mission is completed, as soon as practicable, repair the vehicle using standard maintenance procedures.

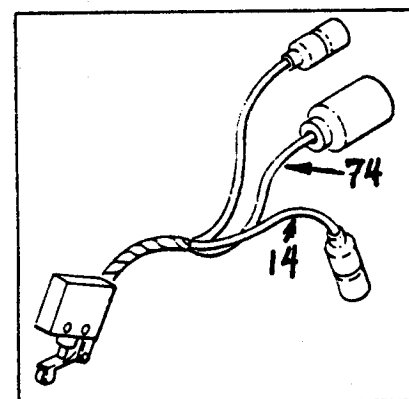
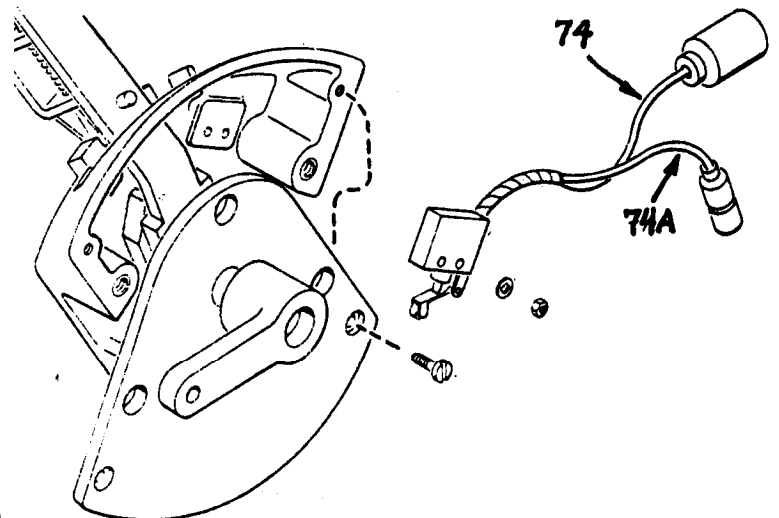

M741 ONLY

### 6-7. GENERATOR FIELD SAFETY SWITCH DEFECTIVE

#### General Information

No charge from the alternator as indicated on the ammeter and caused by a defective field safety switch (on fuel filter).

#### Limitations

● Continued usage of a bypassed switch will cause eventual damage to the fan tower pulley and shaft.

#### Personnel/Time Required

- 1 soldier
- 5 minutes

#### Materials/Tools:

- Metal pin
- Bare jumper wire
- Knife

#### Other Options:

● The wires may be stripped and twisted together, if necessary.

#### Procedural Steps:

1. By-pass the field safety switch (fuel pressure switch), located on the secondary fuel filter.
2. Disconnect the cable lead.
3. Connect circuits 1A and 1B of the cable with a jumper wire. This allows current to energize the alternator field circuit.
4. Record the BDAR action taken. When the mission is completed, as soon as practicable, repair the vehicle using standard maintenance procedures.

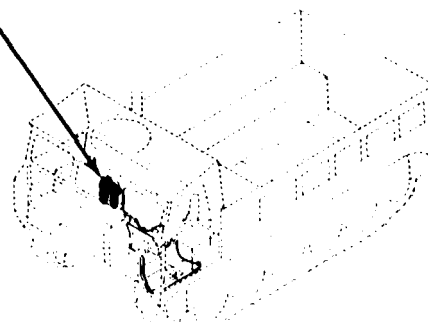
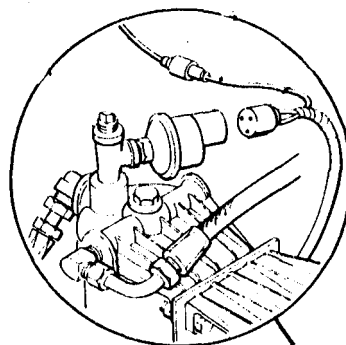
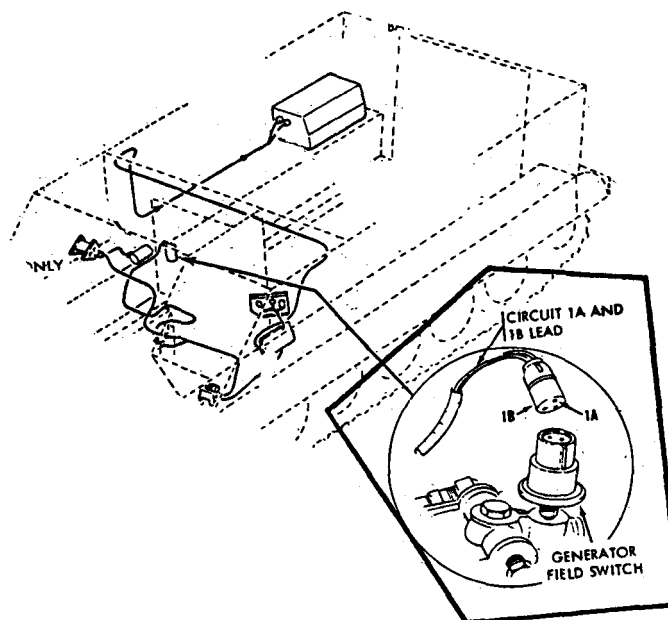



## CHAPTER 7 POWERTRAIN/STEERING

BDAR FIXES SHALL BE USED ONLY IN COMBAT  
AT THE DISCRETION OF THE COMMANDER  
AND SHALL BE REPAIRED BY STANDARD MAINTENANCE PROCEDURES  
AS SOON AS PRACTICABLE AFTER THE MISSION IS COMPLETED.

### SECTION I. General

#### 7-1. General.

The M113 Family of Vehicles (FOV) power train delivers power from the engine through a transfer case to an automatic, three speed forward, one speed reverse transmission. The transfer assembly has an in/out drive plate connection to disengage the transmission. The transmission delivers power to a control differential which produces the steering control and delivers power to the right and left final drives.

Steering is provided by application of brake shoes internal to the control differential. A pivot steer capability is provided through two master cylinders and disk brake calipers mounted external to the control differential.

#### 7-2. Assessment Procedure.

a. Pre-conditions: Vehicle brakes should be in working condition. The vehicle engine must run to assess the powertrain using this procedure.

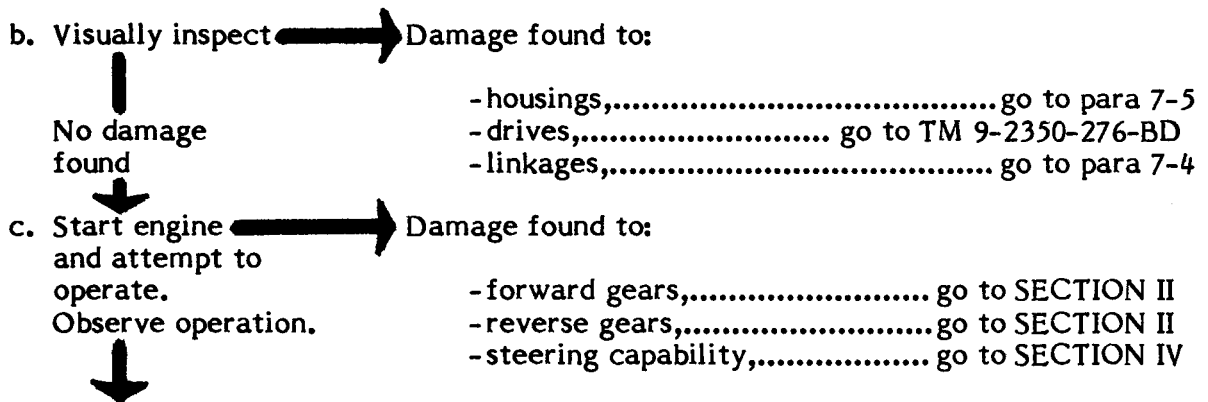

d. Check powertrain/steering performance:

**Powertrain/Steering Assessment**

	Fully Mission Capable	Combat Capable	Combat Emergency Capable	Self Recovery Capable	Recover
- all gears and steering	X	X	X		
- reverse, one forward gear and steering		X	X	X	
- one gear only and steering			X	X	X
- one gear only; no steering			X	X	X
- no gears, no steering			X		X

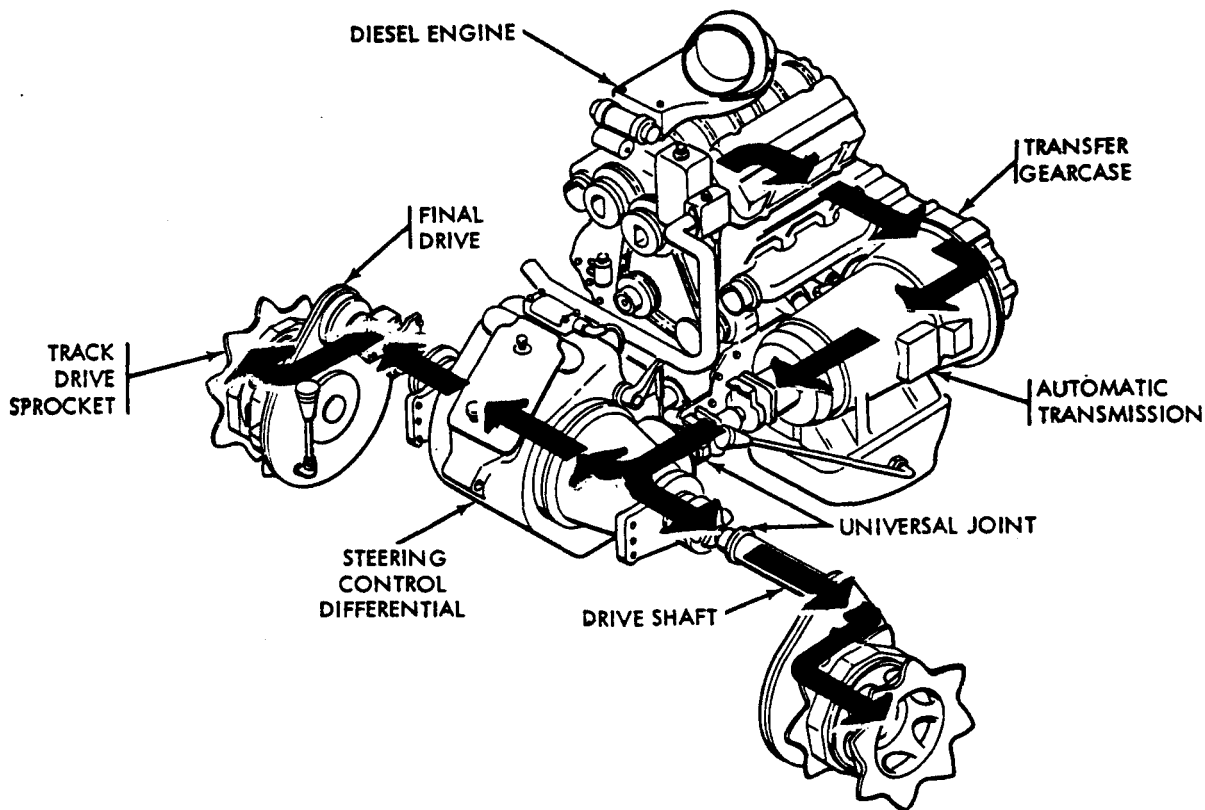

Figure 7-1. Powertrain Power Flow

7-3. BDAR Procedure Index

	<b>Para</b>
Gearshift Linkage Broken .....	7-4
Transfer Assembly Interchangeability .....	7-5
Brake Linkage Damaged .....	7-7

## SECTION II. Transmission

### 7-4. GEARSHIFT LINKAGE BROKEN

#### General Information:

If the gear shifting control linkages are damaged emergency transmission range selection can be performed through the engine access panel in the drivers compartment or power plant door in the crew compartment.

#### Limitations:

- Degraded mobility

#### Personnel/Time Required

- 1 soldier
- 10 minutes

#### Procedural Steps:

1. Open engine access panel in drivers compartment or power plant access door.
2. Remove or disconnect damaged linkage.
3. Set shift lever to neutral to enable Neutral Safety Switch, so vehicle can be started.
4. Shift gear at transmission. Use caution to determine whether the vehicle is in reverse or a forward gear.
5. Close powerplant access door.
6. Record the BDAR action taken. When the mission is completed, as soon as practicable, repair the vehicle using standard maintenance procedures.

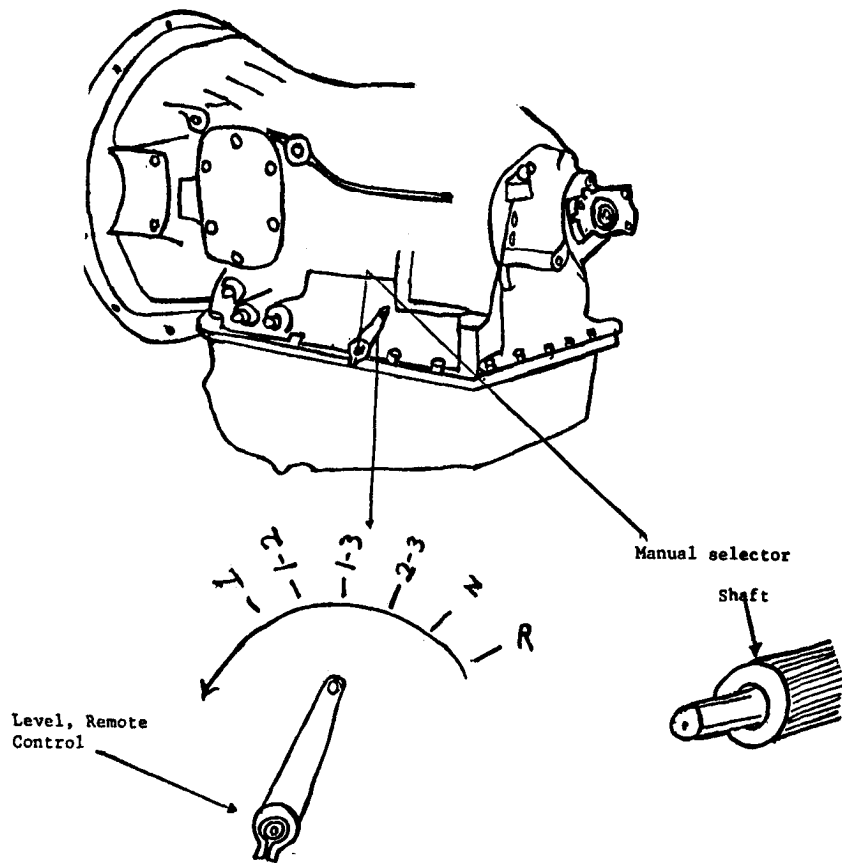

### SECTION III. Transfer Assemblies

#### 7-5. TRANSFER ASSEMBLY INTERCHANGEABILITY

**General:**

The transfer cases within the M113 FOV are physically interchangeable. Some differences will affect operational capabilities of certain vehicles.

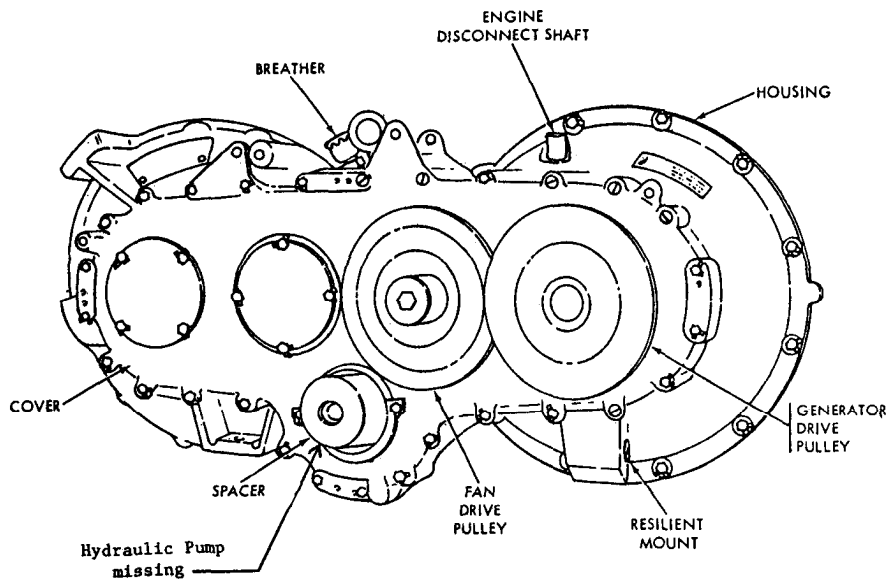

a. M548, M730 and M667:

The transfer cases have no hydraulic oil pumps. If used in the vehicles with a ramp, the ramps system will not function resulting in a free-fall ramp condition. The fan drive pulley is driven by their first intermediate gear rather than the second intermediate gear. The fan and generator (alternator) drive pulleys are single belt drives.

TM 9-2350-275-BD  
POWERTRAIN/STEERING

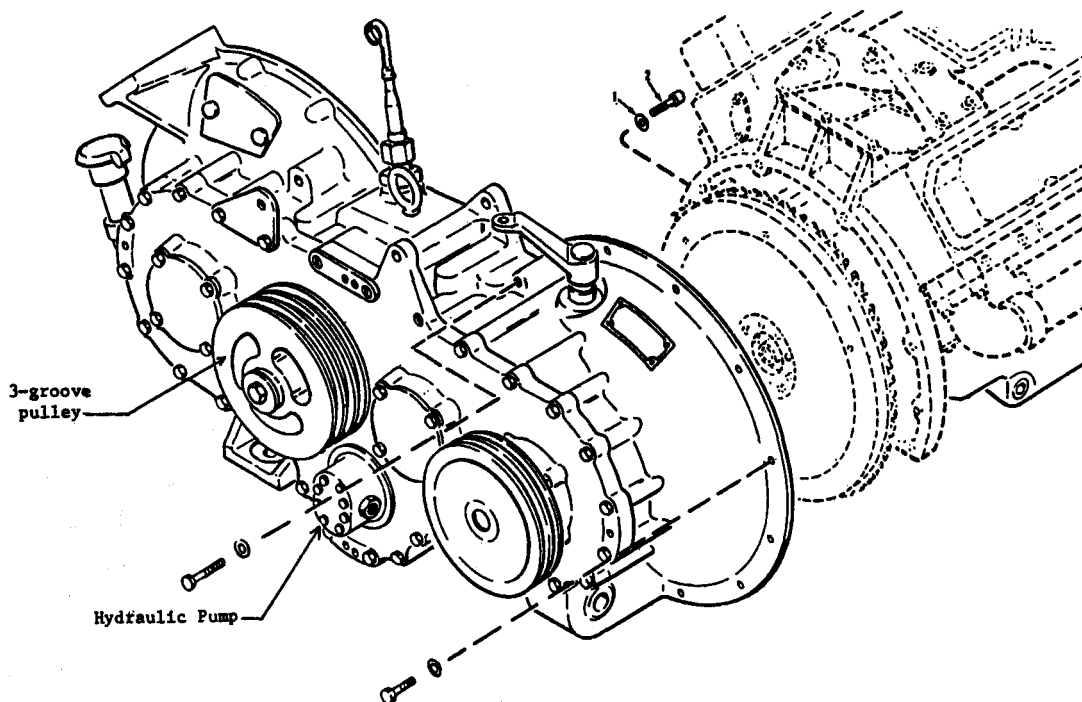

**b. M113A2, M106A2, M125A2, M577A2, M741A1 and M901:**

Vehicles with improved cooling systems have a three-groove fan drive pulley. Fan drive pulley is driven by the second intermediate gear. The hydraulic ramp pump powers the rear exit ramp.



**TM 9-2350-275-BD**  
**POWERTRAIN/STEERING**

**7-7. BRAKE LINKAGE DAMAGED**

**General Information**

Braking and steering is accomplished through mechanical linkage to the control steer differential. Binding linkage or corroded steering lateral cross-shafts can cause the brakes to remain locked, or not fully released. This procedure gives the method to follow if normal repair is not possible because of lack of time or parts.

**Limitations**

- Degraded mobility

**Personnel/Time Required**

- 1 soldier
- 10 to 30 minutes

**Materials/Tools**

- Large screwdriver or pry bar
- Hammer

**Procedural Step**

1. Check mechanical linkage beginning with the locking pawl and quadrant on the steering laterals.
  - a. Open the engine armor door,
  - b. Raise seats for the M548 and M730.
2. Check all linkage leading to the steer differential.
3. Pry linkage loose to disengage brakes.
4. If linkage cannot be made to operate freely, pry linkage to fully released position or disconnect linkage at steer differential.
5. Braking and steering is then accomplished by down-shifting and by use of pivot steer.
6. Record the BDAR action taken. When the mission is completed, as soon as practicable, repair the vehicle using standard maintenance procedures.



## CHAPTER 8

### TRACK AND SUSPENSION

BDAR FIXES SHALL BE USED ONLY IN COMBAT  
AT THE DISCRETION OF THE COMMANDER  
AND SHALL BE REPAIRED BY STANDARD MAINTENANCE PROCEDURES  
AS SOON AS PRACTICABLE AFTER THE MISSION IS COMPLETED.

#### SECTION I. General

##### 8-1. General.

a. When track or suspension components are damaged, the carrier can operate by eliminating some positions. Maintaining a tight track and uniform ground pressure will be a problem. As more roadwheels, arms, and torsion bars are damaged, there is less to support the vehicle load. This will result in reduced ground clearance and heavier loading on remaining components. The crew must control the speeds, limit the agility of movement and select smoother terrain if the tactical situation permits. Imbalance and mismatch from side to side will not only cause a control problem for the driver, but will consume engine power and directly affect the top speed of the vehicle.

b. Many items within the suspension assembly are identical regardless of position, but some have minor differences from left to right and front to rear. In an emergency situation, these parts can be used as a substitute despite the fact they carry a different NSN.

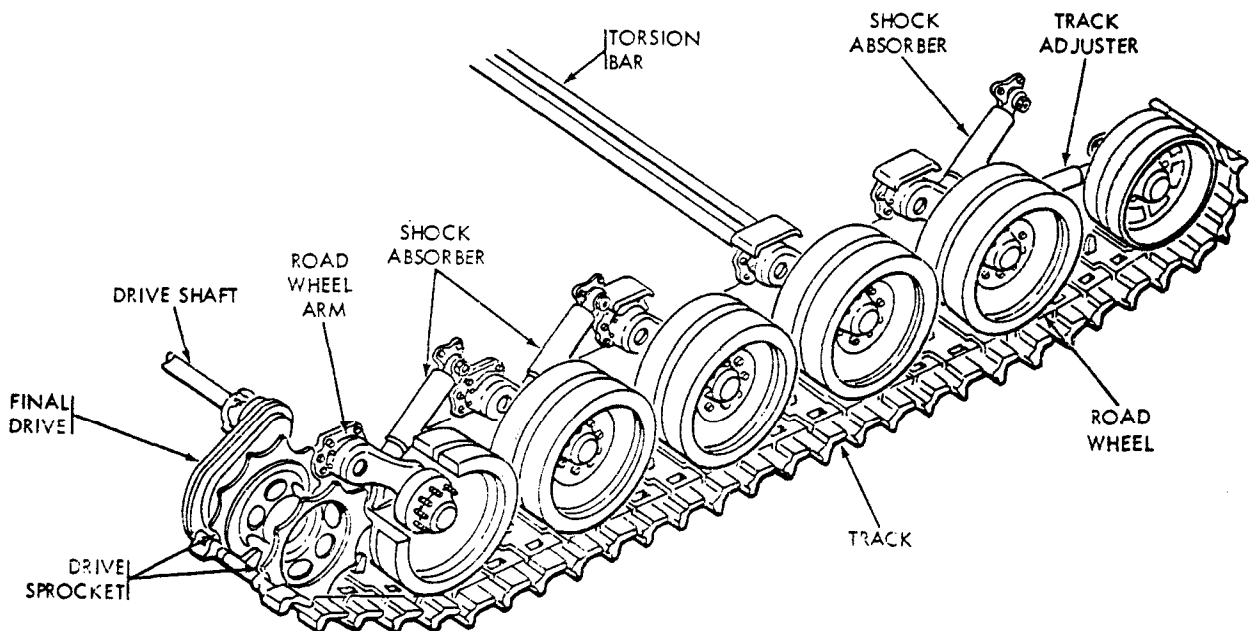

**TM 9-2350-275-BD**  
**TRACK AND SUSPENSION**

**8-2. Assessment Procedure.**

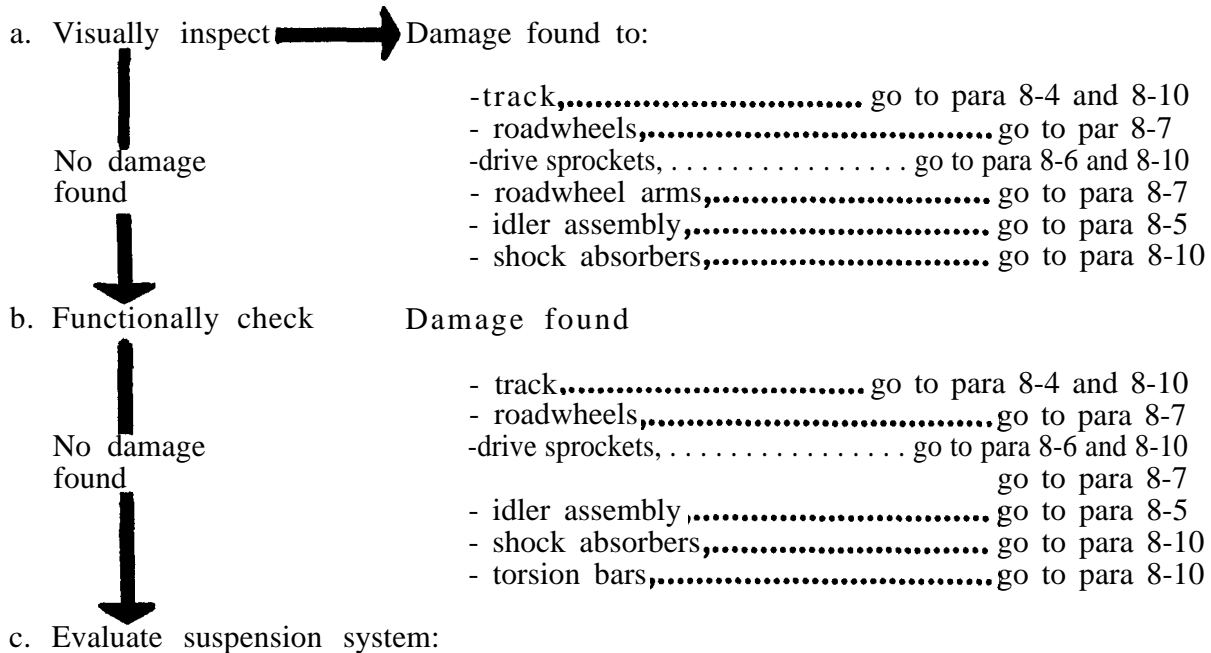

**Track and Suspension Assessment**

	Fully Mission Capable	Combat Capable	Combat Emergency Capable	Self Recovery Capable	Recover
-All components serviceable	X	<b>X</b>	<b>X</b>	<b>X</b>	
-Both tracks, drive sprockets, idlers, and positions 1 and 5 with 2 other positions serviceable		<b>X</b>	<b>X</b>	<b>X</b>	
-Both tracks, drive sprockets, idlers and positions 1 and 5 serviceable		<b>X</b>	<b>X</b>	<b>X</b>	
-Either track, drive sprocket, idler or position 1 and 5 unserviceable					X

**8-3. BDAR Procedure Index.**

Track, Partially Thrown ..... 8-4  
Short-Tracking, Idler Assembly Damaged ..... 8-5  
Drive Sprocket or Hub Bolts Sheared..... 8-6  
Roadwheel/Hub Damaged ..... 8-7  
Roadwheel Arm Housing Sheared ..... 8-8  
Roadwheel Arm Damaged ..... 8-9  
Suspension Component Interchangeability..... 8-10

## SECTION II. Track

### 8-4. TRACK, PARTIALLY THROWN

#### General Information

Quick, sharp turns sometimes result in a partially thrown track. Tracks can be replaced without resorting to breaking track. A shorter method using wedging material to cam the track into place can be utilized.

#### Limitations

- None

#### Personnel/Time Required:

- 2 soldiers
- 25 minutes

#### Materials/Tools:

- Pry bar
- Rocks
- Block of wood

#### Other Options

#### Procedural Steps

1. Loosen track adjuster to relieve track tension.
2. Remove the skirts.
3. Place wedging material between the top of roadwheel and track. Hold the objects in place with a rod or pole.
4. Move the vehicle slowly so the wedge will move with the roadwheel to lift the track off of the roadwheel. The wedge should be large enough to lift the track center guide above the **roadwheel**.

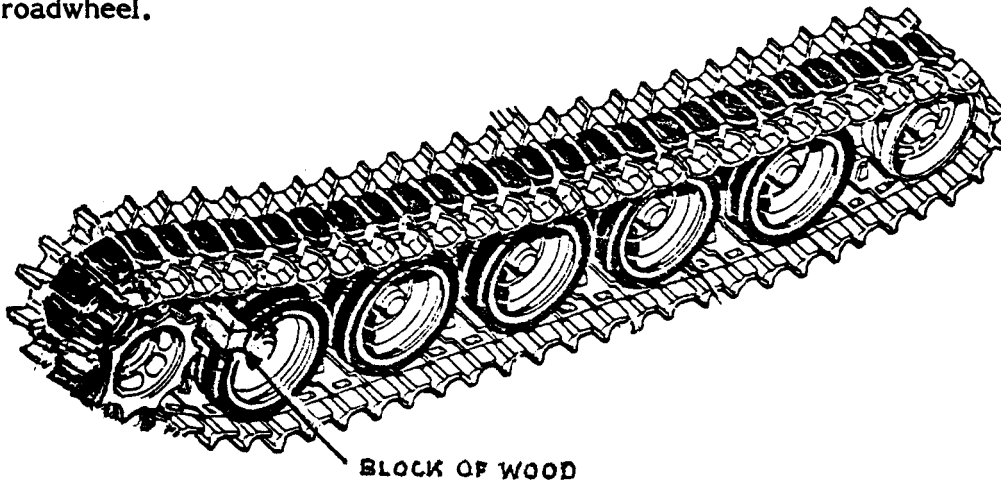

### Procedural Steps (Cont)

5. Pry track into place using a crowbar. If a bar is not available, or if attempt is unsuccessful, move the vehicle about a foot back and forth repeatedly, with the rocks in place, until the track straightens itself and the track center guide is in place. Pivot steer may be applied to put a side load on the track.

### CAUTION

Good coordination is required between the one placing the wedging material and driver.

6. Remove the wedge and readjust the track.
7. Re-install the skirts.
8. Record the BDAR action taken. When the mission is completed, as soon as practicable, repair the vehicle using standard maintenance procedures.

## 8-5. SHORT-TRACKING, IDLER ASSEMBLY DAMAGED

### General Information

Use this procedure if the hull mounting plate for the idler assembly is damaged beyond use or if there is no replacement available for a damaged idler wheel or idler arm assembly. The maximum speed, on good terrain will be limited to 10 mph.

### Limitations:

- Degraded mobility

### Personnel/Time Required

- 2 soldiers
- 2-3 hours

### Procedural Step

1. Separate track midway between 4th and 5th roadwheel.
2. Remove idler assembly from hull idler plate.
3. Remove track adjuster.
4. Remove shock absorber from rear roadwheel support arm.

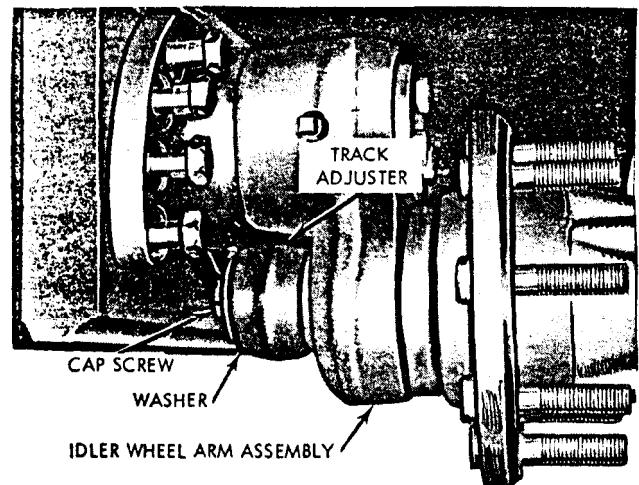

**TM 9-2350-275-BD**  
**TRACK AND SUSPENSION**

5. Remove shock absorber mount and track adjuster mount from hull.

6. Remove seven track shoes from the track.

7. Pull track end up and over the 5th wheel (rear), reconnecting it between the 4th and 5th roadwheel.

8. Record the BDAR action taken. When the mission is completed as soon as practicable, repair the vehicle using standard maintenance procedures.

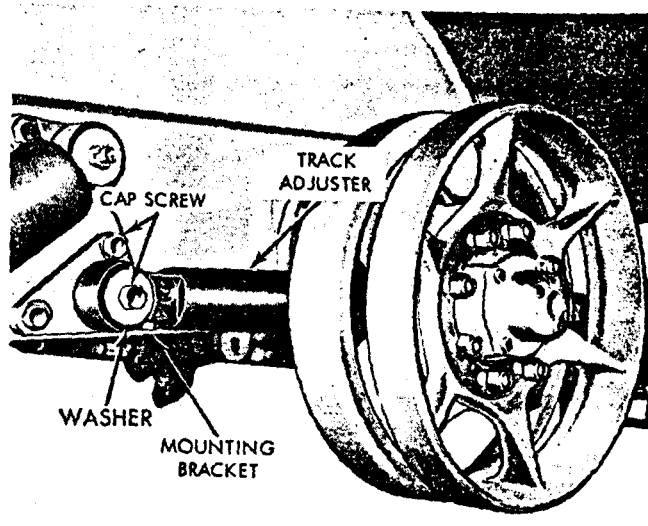

**SHOCK AND ADJUSTER**

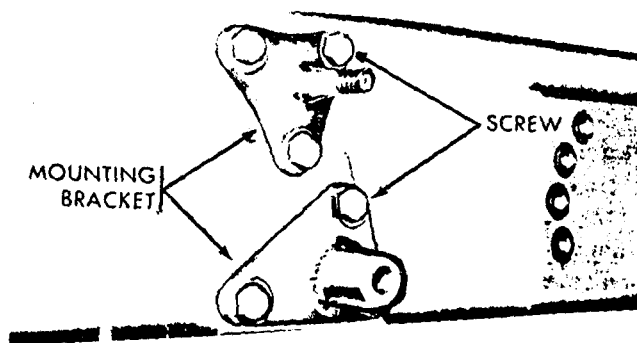

**BRACKETS TO BE REMOVED.**

### SECTION III. Drive Sprocket and Roadwheels

#### 8-6. DRIVE SPROCKET OR HUB BOLTS SHEARED

##### General Information

Loosening of bolts which hold the drive sprocket carrier to the final drive output hub may cause the bolts to be sheared. Operation may continue with as few as five (5) bolts remaining, provided that they are equally spaced around the hub. If the hub is welded or less than a full set of bolts is used, do not use pivot steer. The side stresses may cause the sprocket to shear again. The drive sprockets can also be remounted using this same procedure.

##### Limitations:

- Degraded mobility

##### Personnel/Time Required:

- 2 soldiers
- 1-2 hours

##### Materials/Tool:

- Arc welder
- 5/8 in x 1-3/4 in cap screws
- Use bolts from the opposite wheel

##### Procedural Steps:

1. Attempt to remove the sheared bolt.
2. If four or less bolts remain, or if three or more consecutive bolts are missing due to damaged bolt holes, weld the sprocket wheel to the final drive output hub.
3. Adjust track tension.
4. Record the BDAR action taken. When the mission is completed, as soon as practicable, repair the vehicle using standard maintenance procedures.

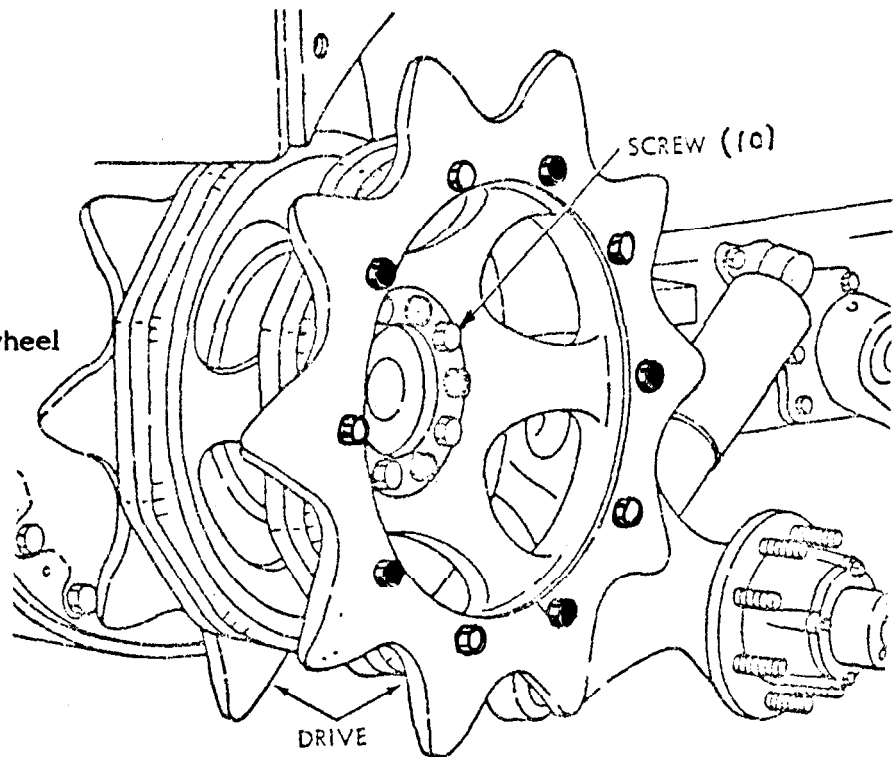

**TM 9-2350-275-BD**  
**TRACK AND SUSPENSION**

**8-7. ROADWHEEL/HUB DAMAGED**

**General Information**

Damaged roadwheel or roadwheel hub must be removed or replaced. Roadwheels on all M 113 FOV are interchangeable, but not all roadwheel hubs. The M113 FOV may be operated in a degraded condition if it is equipped on each side with:

- a. Drive sprocket
- b. Idler wheel
- c. Roadwheels No. 1 and No. 5
- d. One othe roadwheel

If No. 1 or No. 5 roadwheels are damaged, they should be replaced. If necessary, use the roadwheel from position No. 2. In order to remove a roadwheel without the proper lifter, some suggestions are offered. In each case loosen the track adjuster beforehand.

**Limitations:**

- Degraded mobility

**Personnel/Time Required:**

- 2 soldiers
- 1-3 hours

**Materials/Tools:**

- Roadwheel lifter
- Substitute lifter

**Other Options:**

- Short track

**Procedural Steps:**

1. Drive the vehicle upon a log or rock in order to raise the roadwheel and allow removal.
2. Cut a block of wood or metal 12 or 15 inches long for a lifter whichever length is required. A piece of 2 in. x 4 in. stud, or a 12 in. crescent wrench will do.
3. For maximum operation with one roadwheel missing, the roadwheel support arm should also be removed or tied up to prevent interference with the track.
4. Remove the six screws holding the roadwheel support arm to the hull.
5. Remove the support assembly and torsion bar as a unit.
6. Record the BDAR action taken. When the mission is completed, as soon as practicable, repair the vehicle using standard maintenance procedures.

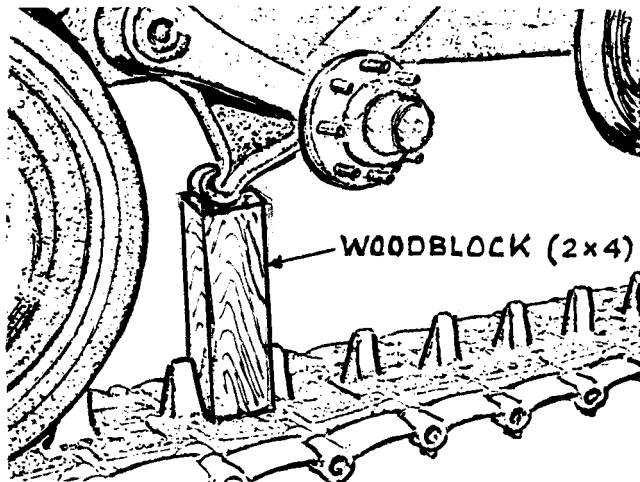



## SECTION IV. Suspension Components

### 8-8. ROADWHEEL ARM HOUSING SHEARED

#### General Information:

A broken roadwheel arm housing or sheared mounting bolts will cause a loss of use of the affected roadwheel position. Roadwheel arm housing are interchangeable between positions.

#### Limitations:

- Reduced mobility

#### Personnel/Time Required:

- 2 soldiers
- 1 hour

#### Materials/Tools:

- Arc welder

#### Procedural Steps:

1. Break track if first or fifth roadwheel position is damaged.
2. Attempt to remove broken bolts from hull at damaged position.
3. Remove housing from position, 2, 3, or 4.
4. Install the housing in the damaged position.
  - a. Use bolts from good roadwheel positions to replace a minimum of 50 percent of the missing/sheared bolts.
  - b. If more than half the bolts cannot be replaced, plug weld through the housing holes to the steel rosan inserts and remains of broken bolts.
5. Reconnect and adjust track.
6. Record the BDAR action taken.  
When the mission is completed, as soon as practicable, repair vehicle using standard maintenance procedures.

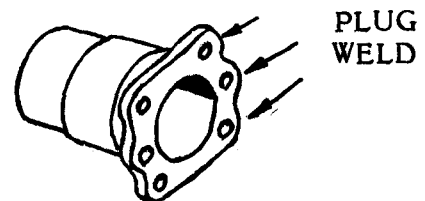
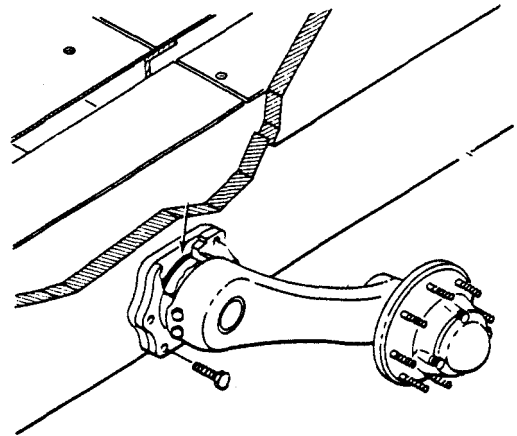

**TM 9-2350-275-BD**  
**TRACK AND SUSPENSION**

**8-9. ROADWHEEL ARM DAMAGED**

**General Information:**

A broken roadwheel arm will cause serious operational limitations, if damage occurs in the first or fifth roadwheel position. If either of these positions is damaged, the complete assembly should be changed from another position. Positions 1 and 5 are critical and are identical to position 2, with shock absorber mounting provisions.

**Limitations:**

- Degraded mobility

**Personnel/Time Required:**

- 2 soldiers
- 1-2 hours

**Materials/Tools:**

- Roadwheel arm support

**Other Options**

- Short track
- Tie up support arm

**Procedural Steps:**

1. Break track if position 1 or 5 is damaged

2. Remove damaged components.

3. Replace arm from another roadwheel position. If 1 or 5 position is damaged, use roadwheel arm from position 2 to maintain shock absorber use.

4. Reconnect and tension track.

5. Record the BDAR action taken. When the mission is completed, as soon as practicable, repair the vehicle using standard maintenance procedures.

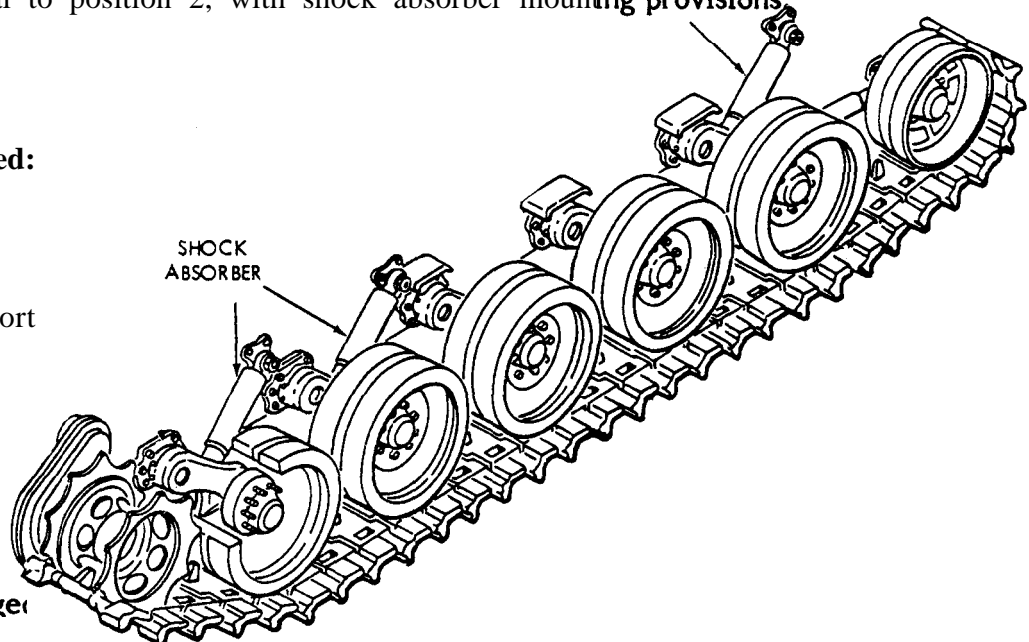

**8-10. SUSPENSION COMPONENT INTERCHANGEABILITY**

**General Information:**

Replacement parts may not be available through normal supply channels. Replacements can be modified if obtained from other vehicles in the M113 Family of Vehicles. Most parts will be usable without modification or improvised mounting.

Improved suspension, A2 series, have heavy duty shock absorbers and torsion bars but these parts will exchange with the older parts. Left and right torsion bars cannot be cross exchanged.

**General Information (Cont):**

Roadwheel support arms although they carry different part numbers are physically interchangeable. Replace shock provisional arms with similar arms if possible.

Drive sprockets, carriers, roadwheels, track, track adjusters and idler wheels are identical throughout the M113 FOV.

The track idler arm assemblies used will need modified mounting provisions. When changing the idler arm assembly the spindle must also be changed. The mounting bolt holes will align with the rosan inserts in the hull if using the updated suspension system or if using the old parts depending on the vehicle being repaired. The six mounting bolts will hold the assembly without major problems.

The opposite side idler arm assembly can be used but only the bottom bolt holes will align. For last resort use only should an idler be used with only two bolts holding the spindle assembly.

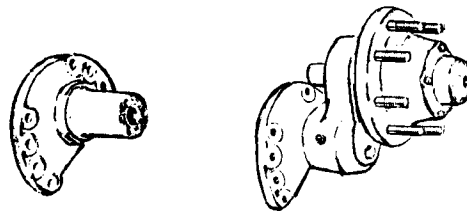

a. M113A1, M577A1, M106A1, M125A1, M548 (M548A1), M730, M741.

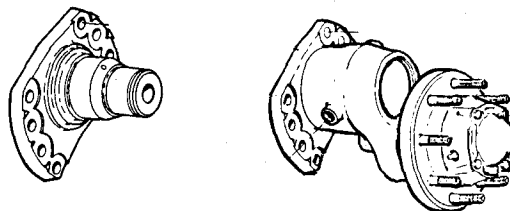

b. M113A2, M577A2, M106A2, M125A2, M901.

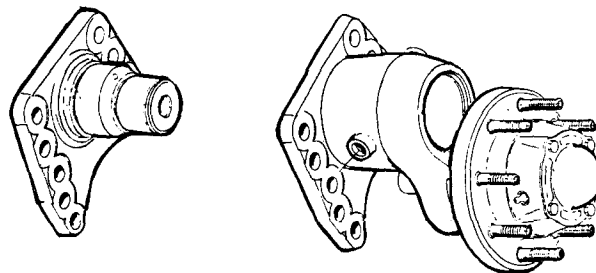

c. M548A1 (M548).

## CHAPTER 9 HYDRAULIC SYSTEM

BDAR FIXES SHALL BE USED ONLY IN COMBAT  
AT THE DISCRETION OF THE COMMANDER  
AND SHALL BE REPAIRED BY STANDARD MAINTENANCE PROCEDURES  
AS SOON AS PRACTICABLE AFTER THE MISSION IS COMPLETED.

### SECTION I. General

#### 9-1. General

BDAR for a hydraulic system is generally confined to component replacement, field expedient line repairs, or bypassing of damaged lines. If a hydraulic circuit cannot be repaired, it may be necessary to isolate it (cutting it off) from the system to permit operation of some other hydraulic functions. General tubing and hydraulic hose repairs are covered in TM 9-2350-276-BD.

#### 9-2. Assessment Procedures.

No specific assessment procedures are needed to locate leaks and ruptured lines.

#### 9-3. BDAR Procedure Index.

Specific M113 Family of Vehicle repairs are still under development. Refer to TM 9-2350-276-BD for general hydraulic repairs.

## SECTION II. Hydraulic Configurations

### 9-4. General

The M113 Family of Vehicles have various configurations of hydraulic systems. The system installed will vary with the needs of the weapons system which is installed. Figures 9-1 through 9-4 show different configurations used in some of all vehicles. BDAR hydraulic line repairs are covered in TM 9-2350-276-BD.

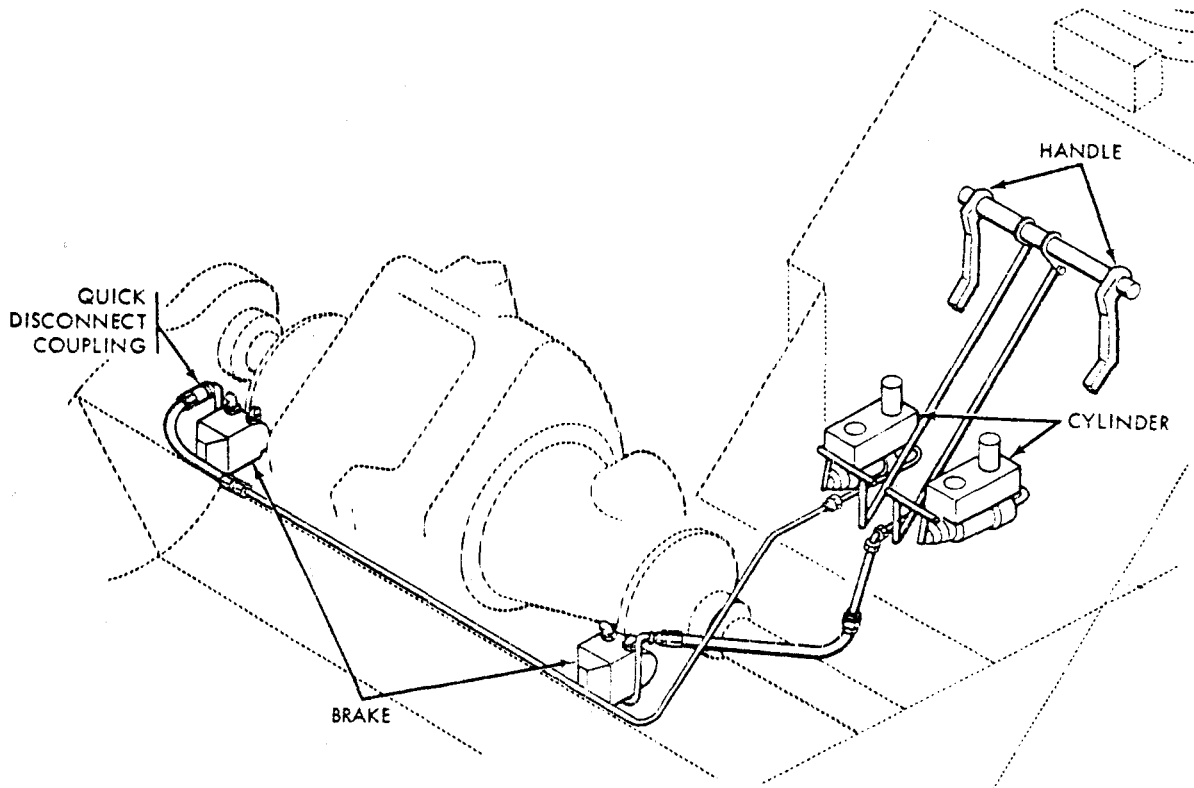

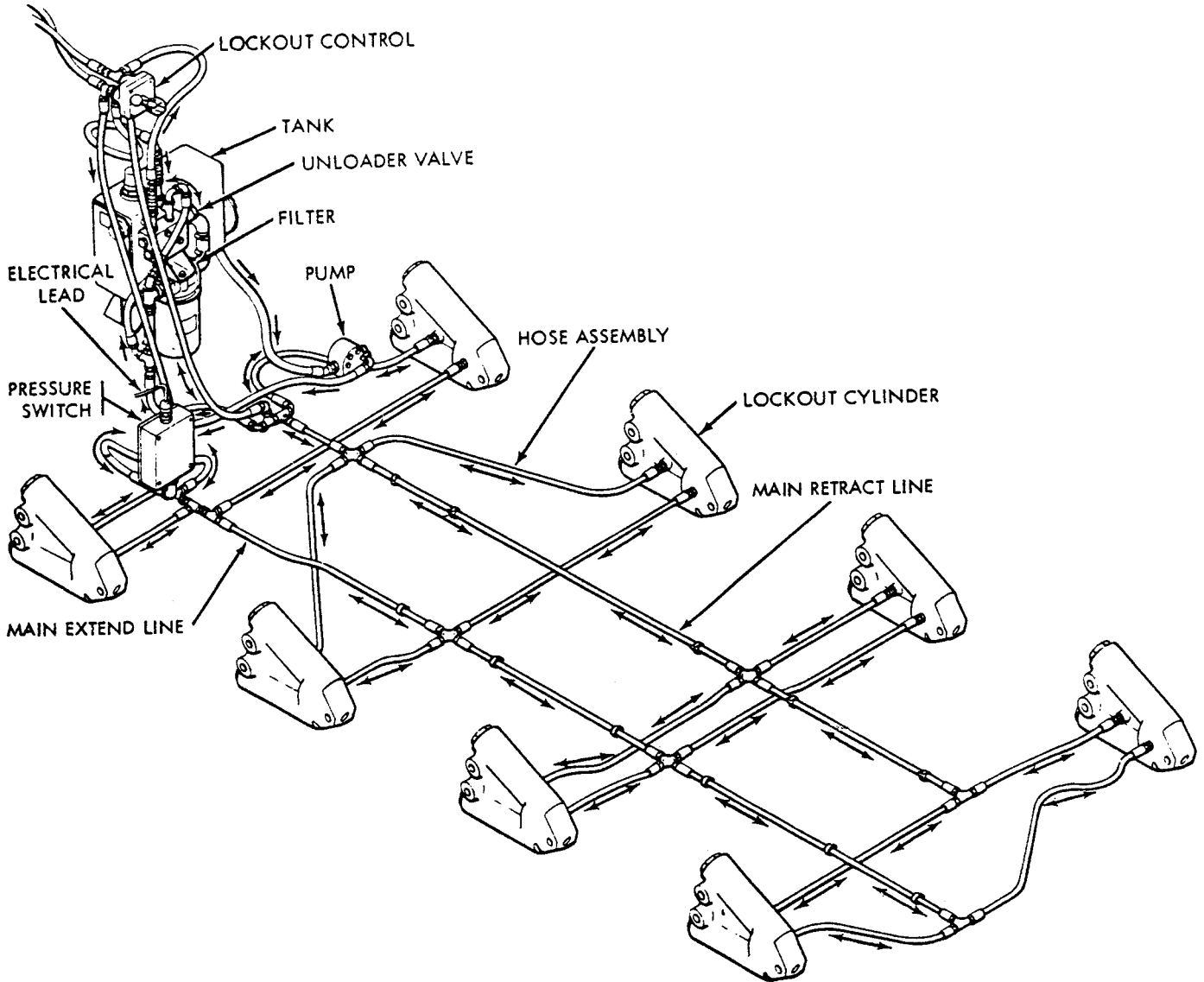

Figure 9-2. Suspension Hydraulic Lockout System (M741)

TM 9-2350-275-BD  
HYDRAULIC SYSTEMS

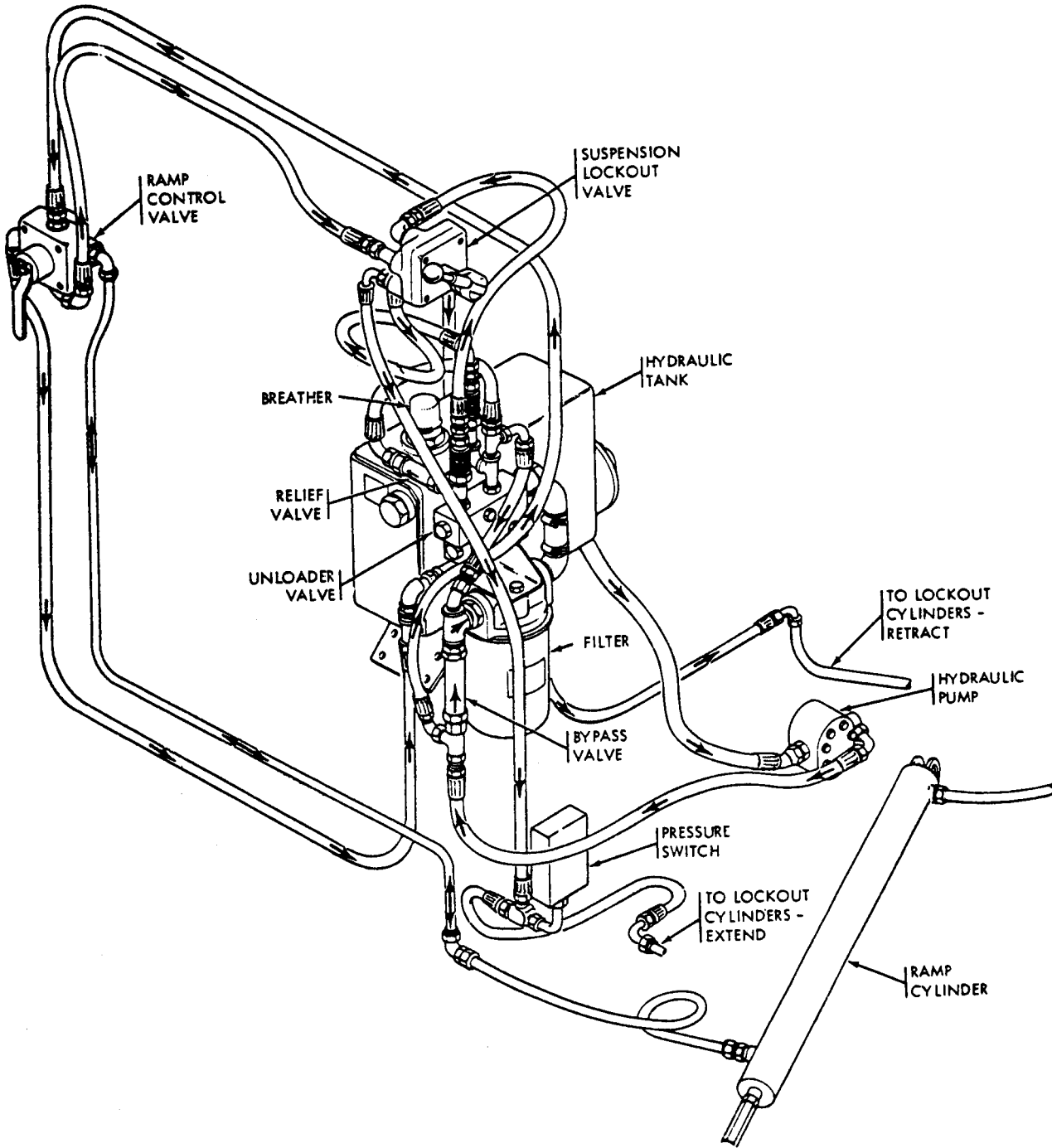

Figure 9-3. Ramp Hydraulic System (M741)

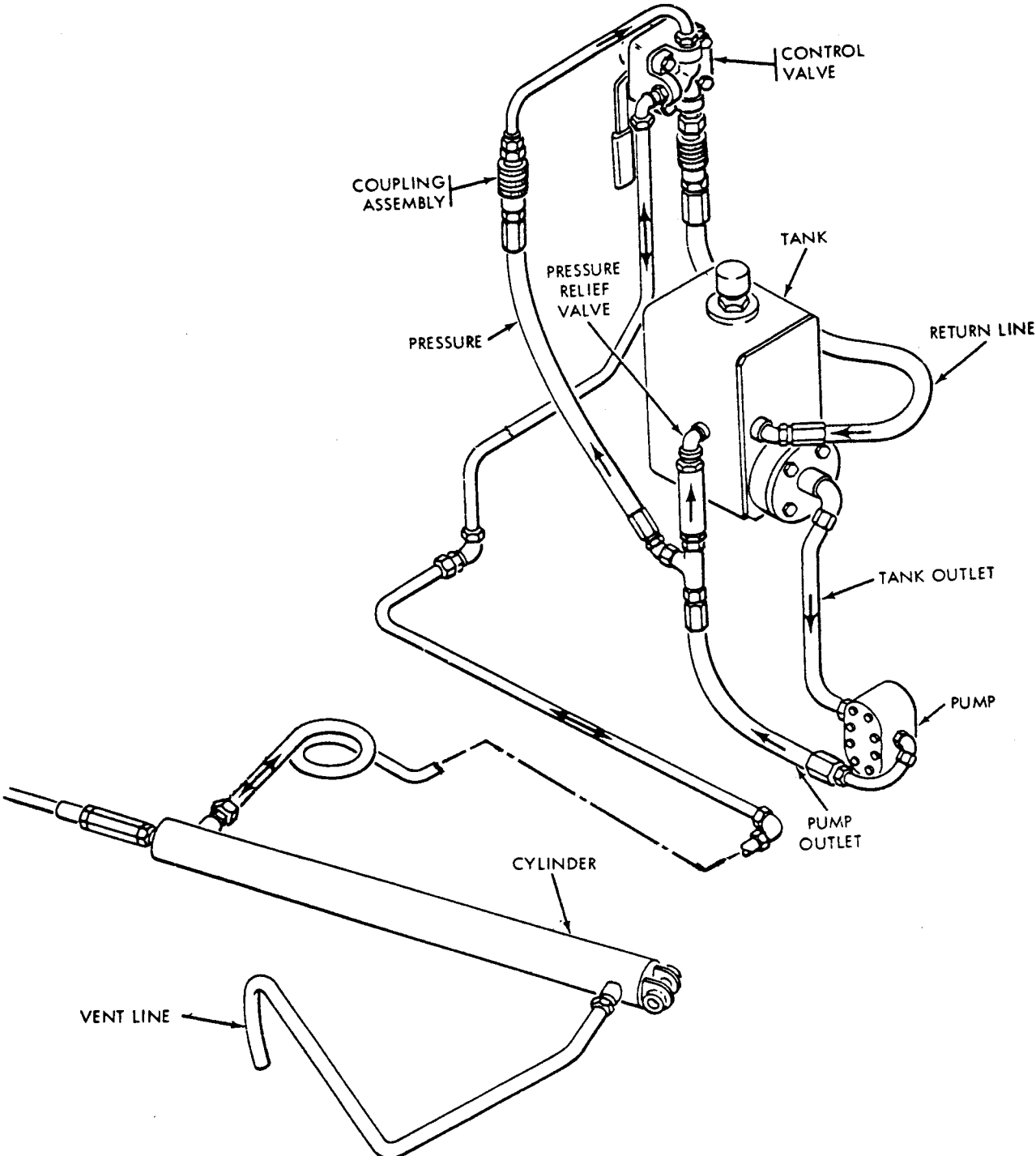

Figure 9-4. Ramp Hydraulic System, Carriers



## CHAPTER 10

### ARMOR

BDAR FIXES SHALL BE USED ONLY IN COMBAT  
AT THE DISCRETION OF THE COMMANDER  
AND SHALL BE REPAIRED BY STANDARD MAINTENANCE PROCEDURES  
AS SOON AS PRACTICABLE AFTER THE MISSION IS COMPLETED.

#### SECTION I. Armor

##### 10-1. General.

M113 Family of vehicles have varying degrees of armor protection. The configuration and alloy will vary with the type of vehicle and its intended mission. Some vehicles have removable armor covers which facilitate battlefield repairs. Fender skirts, access covers and add-on armor plating are easily removed and replaced with fabricated substitutes. Cast hulls and turrets as well as hulls and turrets manufactured from welded armor plates are difficult to repair. Armor alloys require preheating to perform proper repairs which will still retain the required protection. Improvised armor repairs can be made but will be limited to improvised patching using bolt-on type repairs or use expedient welding procedures in Appendix B to weld on patches if normal welding equipment is not available.

##### 10-2. Assessment Procedure.

Assessment of armor will consist of a visual inspection to determine the extent of damage and repairs required.

##### 10-3. BDAR Procedure Index.

Procedures for improvising hang-on type armor to restore some crew protection are still under development.

**SECTION II. Improvised Armor**

**10-4. General.**

Crew protection against mines can be enhanced by placing sandbags on the floor of the vehicle. Sandbags tied to the top of the vehicle will also give some protection against small arms fire. Other methods are also possible, limited only by materials and tools available.

## CHAPTER 11

### COMMUNICATION SYSTEMS

BDAR FIXES SHALL BE USED ONLY IN COMBAT  
AT THE DISCRETION OF THE COMMANDER  
AND SHALL BE REPAIRED BY STANDARD MAINTENANCE PROCEDURES  
AS SOON AS PRACTICABLE AFTER THE MISSION IS COMPLETED.

#### SECTION I. General

##### 11-1. Scope.

This chapter contains the fault assessment and expedient repair procedures needed to locate and fix battlefield damage to a vehicle's communications system.

##### 11-2. General.

The procedures in this chapter are used to repair battlefield damage to the AN/VIC-1 intercommunications set, the radio systems, the KY-57 (KY-38) speech security system and all associated wiring and cables.

##### 11-3. Functional Details.

a. The AN/VIC-1 intercom set consists of the AM-1780 amplifier, four C-10456 or C-2298 control boxes, one C-2742 remote switching control box, four CVC helmets and all associated wiring and cables. The AN/VIC-1 allows voice intercom between the vehicle commander and all crew members.

b. Three basic configurations of radio systems are installed in most tracked vehicles. All three radio systems supply nonsecure frequency modulation (FM) voice radio capabilities through the AN/VIC-1 intercom set to the tank commander and all crew members. All three radio systems utilize the MT-1029 mount for the basic receiver-transmitter and the MT-1898 mount for the auxiliary receiver. The MX-6707 matching unit is used in conjunction with all receiver-transmitters and the AB-558 mast base is used in conjunction with the auxiliary receivers. The AS-1729 antenna system is used with all receiver-transmitters and either the MS-116A, MS-117A, and the MS-118A antenna elements or the AT-1095 antenna element is used with the auxiliary receivers. All associated wiring and cables are the same for each system.

**TM 9-2350-275-BD**  
**COMMUNICATIONS SYSTEM**

(1) The AN/VRC-12 consists of a RT-246 receiver-transmitter which has 10 preset channels which can be automatically switched and tuned by means of the C-2742 remote switching control box and a R-442 auxiliary receiver.

(2) The AN/VRC-47 consists of a RT-524 receiver-transmitter and R-442 auxiliary receiver.

(3) The AN/VRC-64 consists of a RT-841 receiver-transmitter, an AM-2060 amplifier and a R-442 auxiliary receiver.

**c.** The two currently used speech security systems provide for secure voice communications when used in conjunction with any of the receiver-transmitters mentioned above.

(1) The Vinson speech security system consists of a J-3513 interconnection box, 335-14 distribution box, KY-57 speech security device, MT-4626 mount and all associated wiring and cables.

(2) The Nestor speech security system consists of a 3-2731 distribution box, 3-3024 interconnection box, KY-38 speech security device, MT-3823 mount, AM-4979 amplifier and all associated wiring and cables.

## **SECTION II. General Operating Procedures**

### **11-4. General.**

This section contains general operating procedures for the AN/VRC-12 series radios (AN/VRC-12, AN/VRC-47 and AN/VRC-64) when used in conjunction with the AN/VIC-1 intercommunications set. TM 11-5830-340-12 lists operating procedures for the system, but for convenience, the main points have been reproduced here.

#### **a. Normal Radio Operation with AN/VIC-1 Intercommunications Set.**

(1) Turn turret power on. Turn MAIN PWR on the AM-1780 to NORM. This position makes power available to the radio and the aux receiver connected to the AM-1780. See figure 14-1.

(2) Turn POWER switch on the radio (connected to 3501) to either HIGH or LOW. This supplies power to the AM-1780.

(3) Turn POWER CKT BKR switch on the AM-1780 to ON. This supplies power to the AM-1780 and to all control boxes connected to the AM-1780.

(4) Turn INSTALLATION SWITCH on the AM-1780 to OTHER position. This is the normal position which allows the radio accessories connected to the control boxes to operate both the radio and the intercom equipment.

(5) Use the RADIO TRANS switch on the AM-1780 to select crew members allowed to transmit with the radio.

CDR and CREW - if all crew members are allowed to transmit.  
CDR ONLY - if only the crew commander is allowed to transmit.  
LISTENING SILENCE - if no one is allowed to transmit.

(6) Select the desired loudness of the intercom and radio signals with the INT ACCENT switch on the AM-1780,

OFF position - both signals have the same loudness.  
ON position - the loudness of the radio signals is reduced below the level of the intercom signals.

(7) To turn off the AM-1780 and radio equipment, turn the MAIN PWR switch on the AM-1780 and the POWER switch on the radio to OFF.

#### **b. Normal Intercom Operation with the AN/VIC-1 Intercommunications Set without radios.**

(1) Turn turret power on. Turn MAIN PWR switch on the AM-1780 to INT ONLY. Power is now available for only intercom equipment. See figure 11-1.

(2) Turn POWER CKT BKR switch on the AM-1780 to ON. This supplies power to AM-1780 and all control boxes connected to the AM-1780.

**TM 9-2350-275-BD  
COMMUNICATIONS SYSTEM**

**NOTE**

Do not place INSTALLATION switch in the INT ONLY position when the AM-1780 is connected to a radio system

(3) Turn INSTALLATION SWITCH on the AM-1780 to OTHER.

(4) Intercom only operation is now possible using the control boxes and the audio accessories connected to them.

(5) To turn off the AM-1780, place the MAIN PWR and POWER CKT BKR switches to OFF.

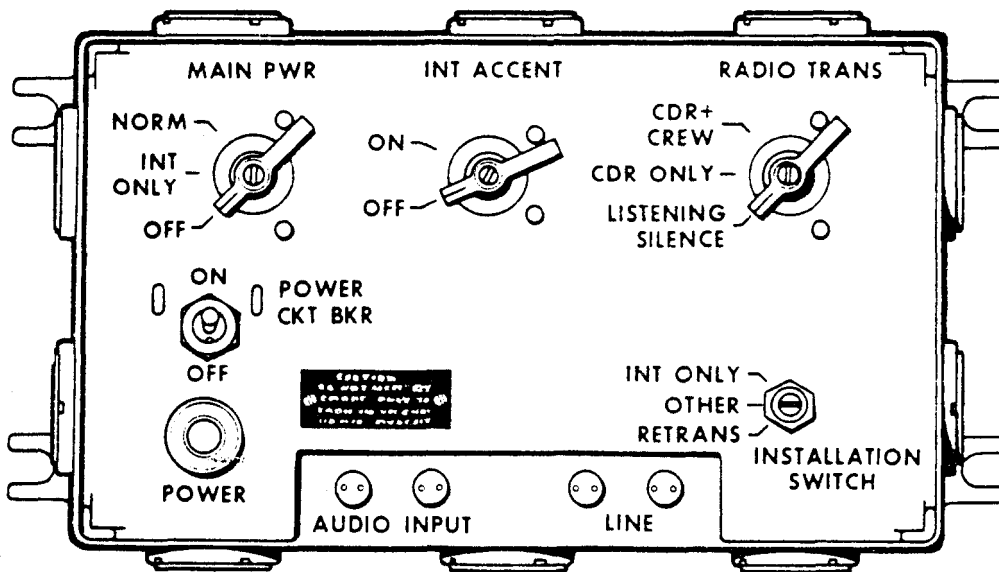

Figure 11-1. AM-1780 Amplifier

c. Normal Radio and Intercom Operation with Crew Members Control Box. See figure 11-2.

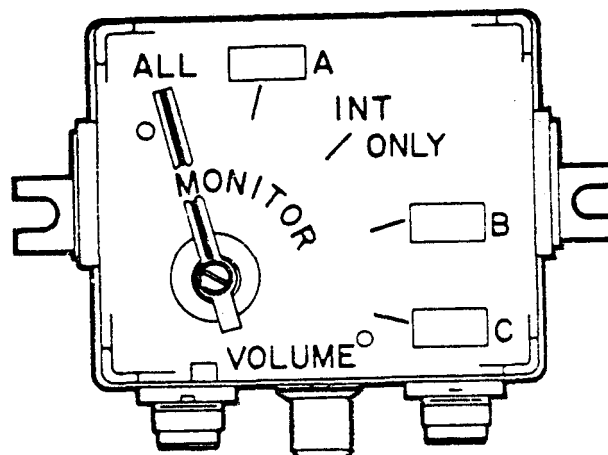

Figure 11-2. Crew Members Control Box

(1) Place the MONITOR switch in the desired position.

(a) ALL - Receives all radio and intercom transmission. Transmit on primary radio and intercom.

(b) A- Receives primary radio and intercom transmission. Transmits on primary radio and intercom.

(c) INT ONLY - Receives and transmits on intercom only. There are no radio capabilities.

(d) B- Receives secondary radio (if equipped) and intercom transmission. Transmits on primary radio and on intercom.

(e) C - Receives third radio (if equipped). Transmits on third radio (if equipped). With this switch position, the only crew member with intercom capability is the crew commander.

(2) Adjust the VOLUME control to a comfortable listening level.

**SECTION III. Fault Assessment Tables and Procedures**

**11-5. Fault Assessment Table and Procedures.**

**a.** Be sure to read Chapter 2 before troubleshooting. The appearance of an assembly or component may indicate its general condition and reflect the type of damage it has suffered. Examine for dented surfaces or holes, torn insulation, severed cables, or other evidence of damage. This might indicate the source of trouble and the need for repairs. Also check component boxes for unusual odors. After obvious damage has been repaired, attempt to operate the communications system to check for damage that might not be so obvious. The procedure below will direct you to a detailed assessment procedure. The detailed assessment procedure leads to an expedient repair procedure, if one exists, for the particular battlefield damage or to another chapter in this manual.

**b.** Intercommunications Set Assessment.

Inspection reveals	Damage:
No Damage Found	-AM 1780 Inoperative; ..... go to para 11-6
	C-2298 or C-10456
	Inoperative ..... go to para 11-7

**c.** Radio System Assessment.

Inspection reveals	Damage:
	-Radio Inoperative (No Power ..... go to para 11-8
	-Radio does not receive ..... go to para 11-9
No Damage Found	-Radio does not transmit; ..... go to para 11-10
	-Radio Inop. in "New Squelch" position; ..... go to para 11-11
	-Aux Receiver Inoperative; ..... go to para 11-12

**d.** Speech Security System Assessment.

Inspection reveals	Damage:
	-System Inoperative (No Power;.. go to para 11-13
No Damage Found	-System Inoperative; ..... go to para 11-14



**11-6. OBSERVABLE SYMPTOM: THE INTERCOM DOES NOT WORK ON ANY CONTROL BOX**

**Detailed Assessment Steps**

1. Make sure the DC power is available to the turret by checking the dome light or other electrical equipment in the turret.
2. Make sure the MK-2096 Transient Voltage Suppressor is operational by checking for a red light on the suppressor. If the light is lit, replace or remove the suppressor.
3. Make sure that the MX-7777 or MX-7778 Transient Voltage Suppressor is operational by depressing the Battle-Override switch. If the suppressor is bad, replace or repair as necessary.
4. Check that communication equipment is turned on and the switches are in the proper positions.
5. Check that cables are connected to the proper connectors, correctly aligned, and tightly connected to the receptacles.
6. Jiggle the cables to check for intermittent opens or shorts.
  - a. If a defective cable is found, follow the procedures listed below:
    - (1) Replace the defective cable in accordance with standard repair procedures.
    - (2) Replace the defective cable with an acceptable replacement cable (refer to para. 11-35).
    - (3) Repair the defective cable in accordance with the repair procedures in para. 11-30.
  - b. If a defective cable is not found, then follow the troubleshooting procedures in TM 11-5820-401-12.

**11-7. OBSERVABLE SYMPTOM THE INTERCOM WORKS ON SOME CONTROL BOXES BUT NOT ALL**

**Detailed Assessment Steps**

1. Repeat steps 4 thru 6 in para. 11-6.
2. Replace CVC helmet and connecting cable with a known operational CVC helmet and connecting cable.
  - a. If the problem no longer exists, replace the defective CVC helmet or connecting cable.

**TM 9-2350-275-BD**  
**COMMUNICATIONS SYSTEM**

- b. If the problem has not been corrected, go to step 3.
3. Disconnect CX-4723 cable leading to the non-operational control box at the AM-1780, and switch it with another CX-4723 cable at the AM-1780 receptacles.

If the same problem occurs in the control box now connected to that receptacle, repair or replace the AM-1780.

- b. If the problem stays with the same control box, go to step 4.
4. Switch the CX-4723 cables back to their original positions on the AM-1780, and replace the non-operational control box with a known operational control box.
  - a. If the problem no longer exists, replace or repair the C-10456.
  - b. If the problem still exists, replace or repair the CX-4723 cable between the control box and the AM-1780. (Refer to para. 11-30.)
5. If the cable and/or the control box cannot be repaired or replaced, install the field expedient intercom described in para. 11-22.

**11-8. OBSERVABLE SYMPTOM: RADIO AND/OR INTERCOM ARE NOT WORKING PROPERLY**

**Detailed Assessment Step**

1. If the radio is working properly but the intercom is not working properly, refer to para. 11-6 and/or 11-7.
2. Make sure the control settings on the AM- 1780 are correct.
3. Make sure the switches on all control boxes are set to ALL.
4. Set all switches on all CVC helmets to the LISTEN or center position.
5. Check CVC helmets and connecting cables in turn by substituting a known operational CVC helmet and connecting cable at each control box.
  - a. If the problem no longer exists, replace or repair the CVC helmet or connecting cable using standard maintenance procedures.
  - b. If the problem still exists, go to step 6.
6. Make sure the radio is firmly seated in the mount by loosening the mount to radio clamps. Move the radio forward. Line up the guide pins and slide the radio firmly back into the mount. Tighten the clamps.
  - a. If the problem no longer exists, no further actions are necessary.
  - b. If the problem still exists, go to step 7.

7. Replace radio with a known operational radio.
  - a. If the problem no longer exists repair the radio using standard maintenance procedures.
  - b. If the problem still exists, go to step 8,
8. Make sure all cables are connected properly.
  - a. If a defective cable is found follow the procedures listed below:
    - (1) Replace the defective cable in accordance with standard repair procedures.
    - (2) Replace the defective cable with an acceptable replacement cable listed in para. 11-35.
    - (3) Repair the cable in accordance with the procedures in para. 11-30 or the electrical chapter of TM 9-2350-276-BD.
  - b. If a defective cable is not found, follow the troubleshooting procedures in TM 11-5820-401-12.

**11-9. OBSERVABLE SYMPTOM: THE RADIO DOES NOT RECEIVE THE DISTANT STATION**

**Detailed Assessment Steps**

1. Check that all switch settings are as described in para. 11-4.
  - a. If the problem still exists, refer to para. 11-8 to check for possible intercom problems.
  - b. If the blower motor does not run or the above procedures do not isolate the fault, go to step 2.
2. Make sure the radio is firmly seated in the mount by loosening the clamps. Move the radio forward. Line up the guide pins and slide the radio firmly back into the mount. Tighten the clamps.
3. Make sure the circuit breaker has not been tripped by turning the radio power switch to OFF BREAKER RESET and then back to LOW or HIGH.

**TM 9-2350-275-BD**  
**COMMUNICATIONS SYSTEM**

4. Make sure the MK-2096 Transient Voltage Suppressor is operational by checking for a red light on the suppressor. If the light is lit, replace or remove the suppressor.
5. Make sure the MX-7777 or MX-7778 Transient Voltage Suppressor is operational by depressing the Battle-Override switch. If the suppressor is bad, replace or repair as necessary.
6. Check the antenna coax cables from the radio to the MX-6707 to make sure they are connected properly.
  - a. If a defective cable is found, follow the procedures listed below:
    - (1) Replace the defective cable in accordance with standard repair procedures.
    - (2) Replace the defective cable with an acceptable replacement cable listed in para. 11-35, then go to step 7.
    - (3) Repair the cable in accordance with the procedures in para. 11-30.
  - b. If a defective cable is not found, go to step 7.
7. Replace radio with a known operational radio. If the problem no longer exists, then the radio should be replaced or repaired using standard maintenance procedures.

**11-10. OBSERVABLE SYMPTOM: THE DISTANT STATION DOES NOT ANSWER RADIO CALLS.**

**Detailed Assessment Steps:**

1. Make sure the radio is transmitting by listening for sidetone when transmitting.
2. Make sure the tuning controls on the radio are set on the proper frequency by tuning them to a different frequency and then resetting them on the assigned frequency.
3. Make sure there is sufficient transmitter power to reach the distant station by transmitting on HIGH power and/or repositioning the vehicle with the whip antenna untied.
4. Check radio by attempting to communicate on an alternate frequency.
  - a. If communications are adequate on the alternate frequency, go to step 6.
  - b. If there are no communications on the alternate frequency, go to step 5.

5. Check the transmitter for normal operation by attempting to communicate with another nearby station.
  - a. If there is no output or if the output is low, then go to step 10.
  - b. If the output power is within acceptable limits, go to step 6.
6. Check the antenna tuning circuits located in the antenna matching unit by having someone listen for the sound of relays operating when the frequency is changed.
  - a. If the sound of relays operating is not heard, manually tune the MX-6707 to the proper frequency.
  - b. If the sound of relays operating is heard, then go to step 7.
7. Make sure the antenna elements are tightly screwed together by turning off the transmitter and retightening the antenna sections.
8. Check that the antenna coax cable connectors are tight.
9. Inspect the coax cable for breaks or torn insulation.
  - a. If a defective cable is found, follow these procedures:
    - (1) Replace the defective cable in accordance with standard repair procedures.
    - (2) Replace the defective cable with an acceptable replacement cable listed in para. 11-35.
    - (3) Repair the cable in accordance with the procedures in para. 11-30.
  - b. If a defective cable is not found, then follow the procedures indicated in step 10.
10. Replace the radio with a known operational radio. Operate radio.
  - a. If communication has been restored, repair the radio in accordance with standard maintenance procedures.
  - b. If the problem still exists, refer to the troubleshooting procedures in TM 11-5820-401-12.

**11-11. OBSERVABLE SYMPTOM: RADIO DOES NOT WORK IN “NEW SQUELCH “ON”**

**Detailed Assessment Steps**

1. Verify that the distant station is transmitting with the squelch switch in the NEW ON position by setting your squelch to NEW OFF and telling the distant station to place his squelch in NEW ON.

**TM 9-2350-275-BD  
COMMUNICATIONS SYSTEM**

2. Verify that the distant station is too far away for squelch operation by trying to communicate with the distant station in the NEW ON squelch position.
3. Make sure the antenna system is properly connected.
4. Make sure the antenna system is properly orientated by untying the whip antenna and/or by repositioning the vehicle.
5. Check the antenna tuning circuits located in the antenna matching unit by having someone listen for the sound of relays operating when the frequency is changed.
  - a. If the sound of relays operating is not heard, manually tune the MX-6707 to the proper frequency.
  - b. If the problem still exists, go to step 6.
6. Replace the radio with a known operational radio.
  - a. If communication has been restored, repair the radio in accordance with standard maintenance procedures.
  - b. If the problem still exists, refer to the troubleshooting procedures in TM 11-5820-401-12.

**11-12. OBSERVABLE SYMPTOM THE AUXILIARY RECEIVER IS NOT OPERATING PROPERLY**

**Detailed Assessment Steps:**

1. Verify that the aux receiver is firmly connected to its mount by loosening the receiver. Move the receiver forward. Line up the guide pins and push the aux receiver firmly back into place. Tighten the clamps.
2. Verify that the aux receiver circuit breaker has not been tripped by turning the aux receiver power switch to OFF and then back to ON RESET.
3. Check that the cables are connected properly and are in good condition.
  - a. If a defective cable is found, follow the procedures listed below:

Replace the defective cable in accordance with standard repair procedures.

    - (2) Replace the defective cables with an acceptable replacement cable listed in para. 11-35.

(3) Repair the cable in accordance with the procedures in para. 11-30 or the electrical chapter.

- b. If the problem still exists, go to step 4.
4. Check that the aux receiver tuning controls are set correctly by attempting to receive a signal from a transmitter operating on a different frequency. Retune the aux receiver to the assigned frequency.
- a. If the problem no longer exists, no further actions are necessary.
  - b. If the problem still exists, go to step 5.
5. Replace the aux receiver with a known operational aux receiver.
- a. If communication has been restored, repair the receiver using standard maintenance procedures.
  - b. If the problem still exists, follow the troubleshooting procedures in TM 11-5820-401-12.

**11-13. OBSERVABLE SYMPTOM: THE KY-57 (KY-38) SPEECH SECURITY SYSTEM DOES NOT HAVE POWER**

**Detailed Assessment Steps**

1. Make sure the circuit breaker has not been tripped by turning off the KY-57 (KY-38) power switch and then turning it back to ON.

Make sure the KY-57 (KY-38) is securely mounted by loosening the clamps and moving the KY-57 (KY-38) forward. Line up the guide pins and slide the KY-57 (KY-38) firmly back into the mount. Tighten the clamps.

3. Check that cables are connected properly.

**NOTE**

Do not attempt to repair any cables. Repair might breach security.

4. Check cables for damaged or torn insulation.
  - a. If a defective cable is found, follow the procedures listed below:
    - (1) Replace the defective cable in accordance with standard repair procedures.
    - (2) Replace the defective cable with an acceptable replacement cable listed in para. 11-35.

**TM 9-2350-275-BD**  
**COMMUNICATIONS SYSTEM**

- b. If the problem still exists, go to step 5.
5. Replace KY-57 (KY-38) with a known operational KY-57 (KY-38).
  - a. If the problem no longer exists, repair the KY-57 (KY-38) using standard maintenance procedures.
  - b. If the problem still exists, refer to the troubleshooting procedures in TM 11-5810-256-OP-4.

**11-14. OBSERVABLE SYMPTOM: UNABLE TO COMMUNICATE USING THE KY-57**

**Detailed Assessment Steps**

1. Check the KY-57 (KY-38) system by attempting to communicate in the PT (plain text) mode with a distant station.
  - a. If PT communication is not possible, refer to paragraph 11-5.
  - b. If PT communication is possible, go to step 2.
2. Make sure the proper code is being used by zeroing the KY-57 (KY-38) and then resetting it with the proper code. (Refer to applicable Communications-Electronics Operation Instructions (CEOI).)
3. Attempt to communicate with a different distant station to make sure the proper code settings are being used.
  - a. If communication is restored, attempt to notify the original distant station in PT that he is using improper code.
  - b. If communication is not established, go to step 4.
4. Make sure the proper pre-operating procedures are being used. (Refer to TM 11-5810-256-OP-4.)
5. Make sure the KY-57 (KY-38) system is properly installed by checking all cables.
6. Replace the KY-57 (KY-38) with a known operational KY-57 (KY-38).
  - a. If communication has been restored, repair the KY-57 using standard maintenance procedures.
  - b. If communication has not been restored, refer to the troubleshooting procedures in TM 11-5810-256-OP-4.



**SECTION IV. Expedient Repair Procedures**

**11-15. GENERAL:** This section contains expedient repair procedures to restore radio and/or intercommunications needed to complete the mission.

**11-16. PROCEDURAL INDEX.**

**WARNING**

Do not touch bare wires on expedient antennas with the radio keyed. You could get burned and/or shocked.

**CAUTION**

Field expedient antennas are fragile and will not take much abuse. The continued use of expedient antennas may result in damage to receiver/transmitter.

The index below is provided as a quick reference to locate specific problems or repair procedures. In the event that the specific repair does not appear to be contained in this section, refer to paragraph 11-5 or the electrical chapter of TM 9-2350-275-BD.

<u>Title</u>	<u>Para</u>
Metallic Whip Antenna Broken .....	11-17
Metallic Whip Antenna Replacement .....	11-18
Metallic Whip Antenna Replacement; Long Wire Antenna .....	11-19
Fiberglass Whip Antenna Replacement .....	11-20
Ground Plane Antenna Field Expedient .....	11-21
Intercommunications System/Field Expedient .....	11-22
Radio System/Field Expedient .....	11-23
Field Expedient Radio Mount Repair .....	11-24
Foreign Equipment Interchangeability (AN/VRC-12 Series) .....	11-25
Foreign Equipment Interchangeability (Soviet Radio R- 123M) .....	11-26
Foreign Equipment Interchangeability (Allied Radios) .....	11-27
Foreign Equipment Interchangeability (Soviet Intercom R-124) .....	11-28
Coaxial Cable Repair .....	11-29
Intercommunications Cable Repair .....	11-30
Cables Are Too Short, BDAR Installation .....	11-31
Isolation of Non-Essential Systems (General) .....	11-32
Isolation of Voltage Suppressors .....	11-33
Field Expedient Radio Remote .....	11-34
General Interchangeability Information .....	11-35
Common Vehicle Cording Diagrams .....	11-36

**TM 9-2350-275-BD  
COMMUNICATIONS SYSTEM**

**11-17. METALLIC WHIP ANTENNA BROKEN**

**General Information:**

This procedure gives splicing instructions for the repair of a metallic whip antenna if all pieces of the broken antenna are available.

**Limitations:**

- Slight reduction in reception and transmission range

**Personnel/Time Required:**

- 1 soldier
- 15 minutes

**Materials/Tools:**

- Stick, dry, 4 to 6-inch length
- Wire, copper or cable, stripped telephone, WD-1/TT, 1-foot length

**Other Options:**

- Replace antenna with
  1. Field expedient antenna (Refer to para. 11-18 or 11-19.)
  2. Field expedient ground plane antenna (Refer to para. 11-21.)

**Procedural Steps:**

1. Scrape off the paint 3 to 6 inches from the broken ends of the antenna with sand, rocks, metal, sandpaper, or a knife. Wipe scraped areas clean.
2. Overlay the cleaned ends. Place a dry stick on top of the overlaid ends and wrap tightly together with wire.
3. If time and equipment are available, solder the connection.

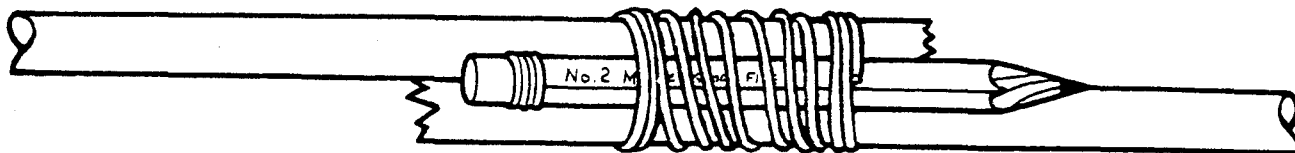

4. Record the BDAR action taken. When the mission is completed, as soon as practicable, repair vehicle using standard maintenance procedures.

## **11-18. METALLIC WHIP ANTENNA REPLACEMENT**

### **General Information:**

This procedure gives instructions for the construction of a field expedient antenna if no other antenna is available.

### **Limitations:**

- Slight reduction in reception and transmission range

### **Personnel/Time Required:**

- 1 soldier
- 15 minutes

### **Material Tools:**

- Pole, wooden or stick, 10-foot length
- Tape, electrical, string or rope
- Wire, copper or cable, telephone, WD-1/TT, 10-foot length

### **Other Options:**

- Repair broken metallic whip antenna (refer to para. 11-17).
- Field expedient replacement antenna (refer to para. 11-19).
- Field expedient ground plane antenna (refer to para. 11-21).

### **Procedural Steps:**

1. Scrape the paint from the top two or three inches of the antenna stub.
2. Attach nine feet of copper wire or telephone cable along the length of the pole with tape. Scrape the insulation from the remaining one foot of wire.

### **NOTE**

Total length of wire and antenna stub should not exceed nine feet.

3. Hold the pole along side the remaining section and base of the antenna. Wrap the bare one foot section of wire tightly around the scraped portion of the broken antenna and wooden pole.
4. Lay the short end of the bare wire on top of the stub. Push wire into the stub hole and jam in place with a wooden peg. Tape peg to stub.

**TM 9-2350-275-BD  
COMMUNICATIONS SYSTEM**

**Procedural Steps (Cont):**

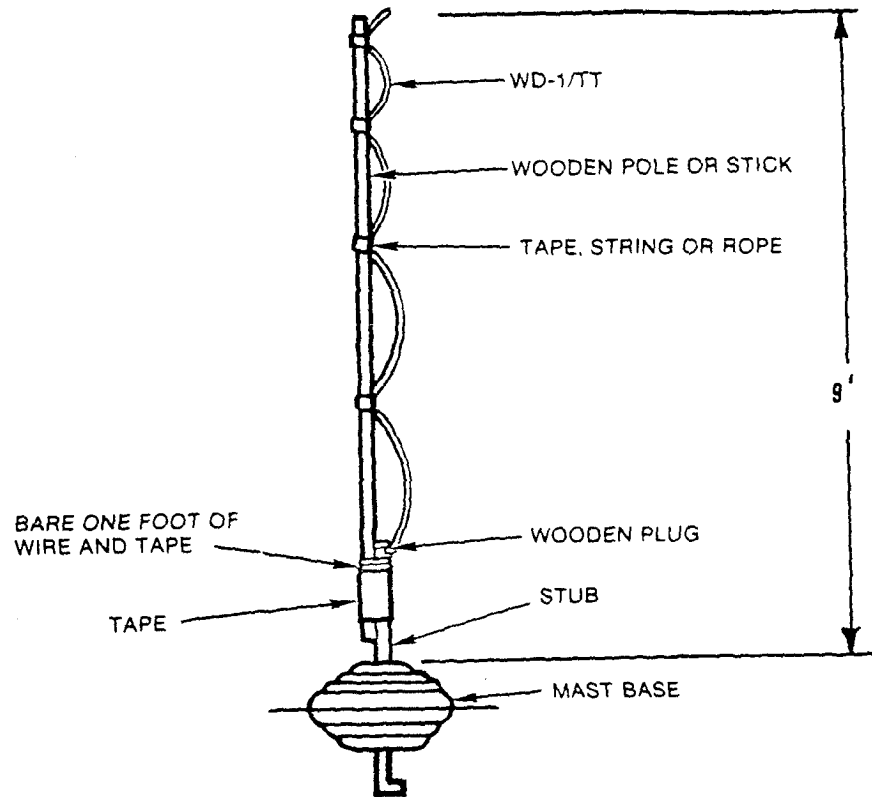

5. Record the BDAR action taken. When mission is completed, as soon as practicable, repair vehicle using standard maintenance procedures.

## 11-19. METALLIC WHIP ANTENNA REPLACEMENT; LONG WIRE ANTENNA

### General Information

This procedure gives instructions for the construction of a long wire antenna for use with the auxiliary receiver if the auxiliary antenna is broken or has been diverted for use with the receiver/transmitter.

### Limitation:

- Cannot be used for transmission
- Reduction in reception

### Personnel/Time Required:

- 1 soldier
- 5 minutes

### Material/Tools:

- Cable, telephone, WD-1/TT 8-foot length
- Tape, electrical

### Other Options:

- Repair broken metallic whip antenna (Refer to para. 11-17.)
- Field expedient metallic whip antenna. (Refer to para. 11-18.)
- Field expedient ground plane antenna. (Refer to para. 11-21.)

### Procedural Steps:

#### CAUTION

Do not use this antenna for transmission. It could damage the radio equipment.

1. Strip approximately two inches of insulation from both leads on one end of the telephone cable.
2. Attach one bare lead to a screw on the R-442 auxiliary receiver.
3. Attach the other bare lead to the center of the antenna connection on the receiver by bending the wire double and jamming it into the hole.
4. Tape or tie the wire to the antenna connector to prevent it from being pulled or vibrated out of the hole.
5. Throw the loose end of the wire out the loader's hatch.
6. Record the BDAR action taken. When the mission is completed, as soon as practicable, repair vehicle using standard maintenance procedures.

**TM 9-2350-275-BD**  
**COMMUNICATIONS SYSTEM**

**11-20. FIBERGLASS WHIP ANTENNA REPLACEMENT**

**General Information**

Since it is not practical to splint a broken fiberglass whip, this procedure gives instructions for construction of a field expedient antenna if no other antenna is available.

**Limitations:**

- Loader's hatch cannot be completely closed
- May result in degraded performance

**Personnel/Time Required:**

- 1 soldier
- 30 minutes

**Materials/Tools**

- Cable, coaxial, RG-8 (NSN 6145-00-161-0887) or RG-58 (NSN 6145-00-161-0908), 20-foot length
- Pencil, nail or sharp stick
- Pole, wooden or stick, 10-foot length
- Rope
- Tape, electrical

**Other Options**

- Utilize the R-442 auxiliary receiver metallic whip antenna by exchanging coaxial cables between receiver/transmitter.
- Replace antenna with field expedient ground plane antenna. (Refer to para. 11-21.)

**Procedural Steps**

1. Measure off and mark but do not cut five feet of coaxial cable.
2. In one foot steps, strip the outer insulation from the cable to expose the braided shield wire. Use care so that the shield wire is not cut.
3. Bend the cable into a loop, holding it with one hand. Using a pencil or nail, and as close to the remaining insulation as possible, carefully separate the braided shield from the insulated center conductor.
4. Work the pencil or nail between the shield wire and center conductor to form a hole. While keeping the loop formed, place a finger in the hole and slowly pull the center conductor out of the shield.
5. Tape the center conductor to the top portion and the braided shield to the bottom portion of a ten-foot pole. Tape as necessary to hold cable securely in place.

Procedural Steps - Continued

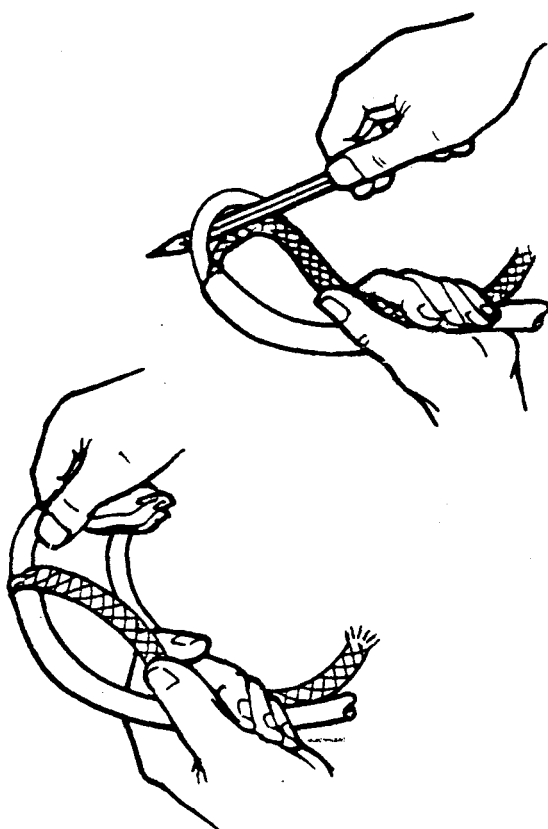

REMOVING BRAIDED SHIELD  
ON COAX CABLE

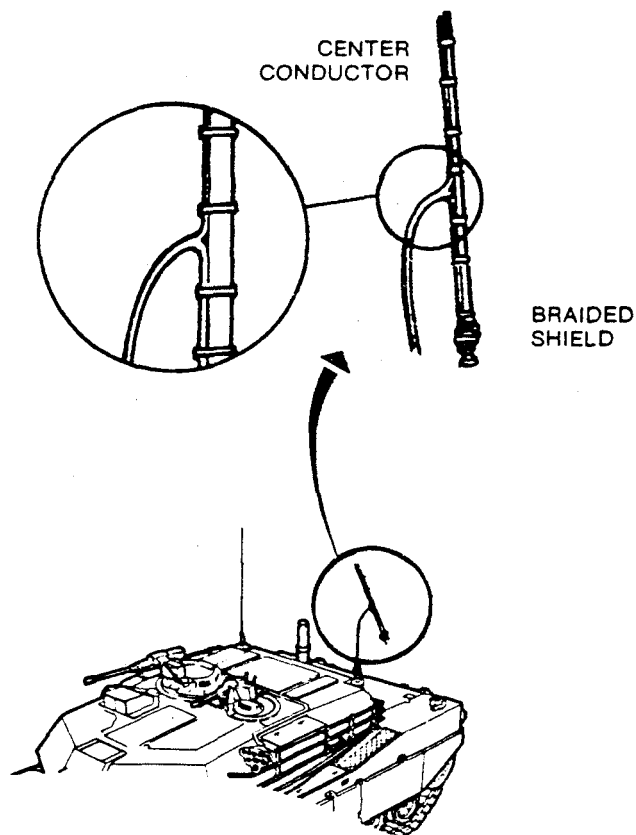

FIBERGLASS WHIP (TAPED)

6. Fasten pole to antenna base with rope or tape.
7. Feed remaining coaxial cable through loader's hatch to the radio.
8. If there is a BNC connector (twist type lock) on the cable, attach it to the radio antenna connector. If not, do as follows:
  - a. Carefully strip the outer insulation of the coaxial cable to expose enough braided shield to reach a screw near the antenna connector on the radio case.
  - b. Use a pencil or nail and carefully separate the braided shield from around the center conductor. Twist into a pigtail.
  - c. Strip the inner insulation to expose enough center conductor to push into the antenna connector.
  - d. Wedge the center conductor into the antenna connector and attach the pigtail to a screw on the radio case.
9. Record the BDAR action taken. When the mission is completed, as soon as practicable, repair vehicle using standard maintenance procedures.

## **11-21. GROUND PLANE FIELD EXPEDIENT ONE-QUARTER WAVE ANTENNA**

### **General Information**

This procedure gives instructions for construction of a one-quarter wave ground plane antenna which can be used for transmission and reception. This antenna has the capability of increasing the range of FM radios.

### **Limitation**

- Can only be used on a stationary vehicle and when a tree is available for suspension of the antenna

### **Personnel/Time Required:**

- 1 soldier
- 30 minutes

### **Materials/Tools:**

- Cable, 1-roll, telephone, WD-1/TT
- Insulators (e.g., glass, plastic, leather, nylon, etc.) (Five required)
- Rope
- Sticks or branches, 3-foot length, (three required)

### **Other Option:**

- Repair broken metallic whip antenna. (Refer to para. 11-17.)
- Field expedient metallic whip antenna. (Refer to para. 11-18.)
- Field expedient replacement of fiberglass antenna. (Refer to para. 11-20.)
- For reception only, field expedient auxiliary antenna. (Refer to para. 11-19.)

### **Procedural Steps:**

1. Determine the length of wire needed for the radiating element of a one-quarter wave antenna using the following formula:

Length (feet) =  $.234 \text{ divided by frequency (MEGAHERTZ)}$

or

Length (meters) =  $71.37 \text{ divided by frequency (MEGAHERTZ)}$

Example- A radiating element for a frequency of 50 MHz

L (feet) =  $234 \text{ divided by } 50 \text{ MHZ} = 4.68 \text{ feet}$

or

L (meters) =  $71.37 \text{ divided by } 50 \text{ MHZ} = 1.43 \text{ meters}$



**Procedural Steps (Cont):**

2. Cut the required length from telephone wire.
3. Cut three reflector elements approximately the same length as the radiating element. Strip the insulation from one end of the three reflectors. Twist together and connect to an insulator.

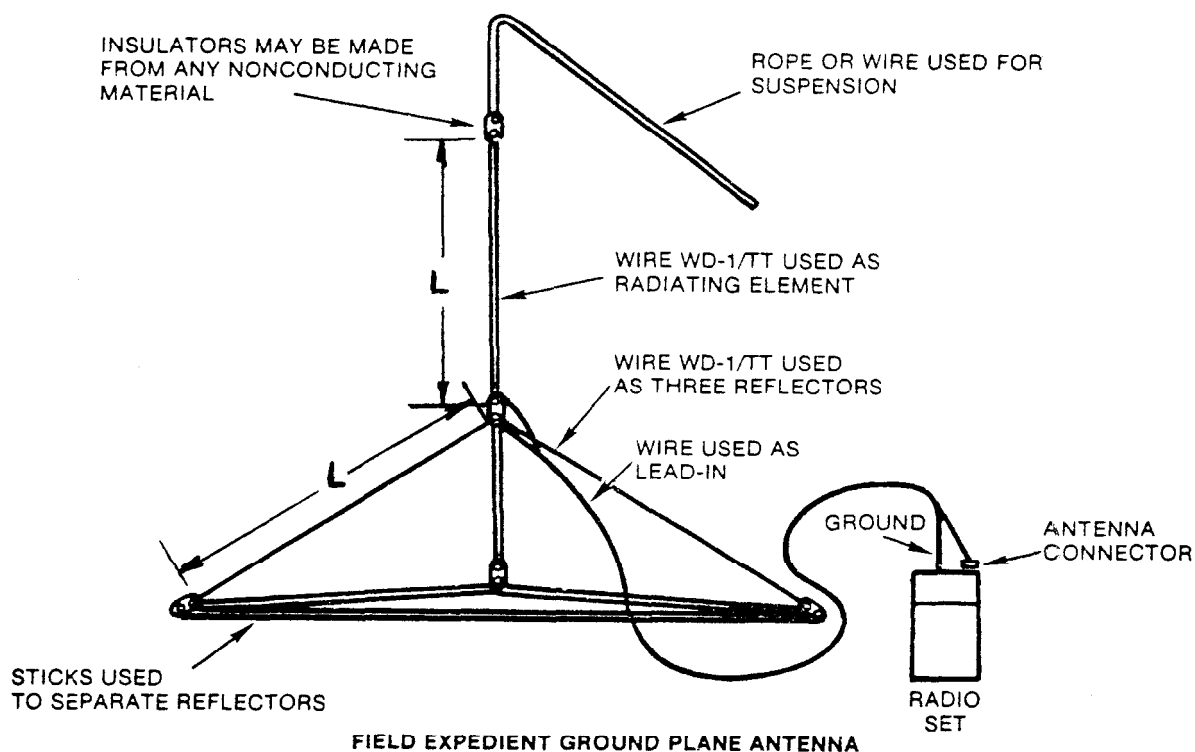

4. Tie together three sticks, 3-feet in length, to form a triangular support for the lower end of the reflector elements.
5. Connect the lower end of the reflector elements and triangular support using three insulators.
6. Connect one end of the radiating element to the insulator at the upper end of the reflector elements. Make sure radiator does not touch the three reflectors.
7. Connect an insulator and a suspension rope or wire to the upper end of the radiating element. If wire is used for suspension, make sure suspension wire does not touch the radiator.

## **TM 9-2350-275-BD COMMUNICATIONS SYSTEM**

### **Procedural Steps (Cont):**

8. Cut a piece of telephone cable long enough to reach from the radio to the desired height of the antenna.
9. Strip the insulation from one end of the two cable wires. Untwist the wires enough to splice one wire to a bare section of the radiating element and the other wire to a bare section of the reflectors.
10. Toss the suspension rope or wire over the limb of a tree, and pull the antenna up to the desired height.
11. Strip insulation from the other end of the two-wire cable. Untwist and connect one wire to a screw on the radio (ground) and the other wire to the center of the radio antenna connector.
12. If communications are not satisfactory, reverse the connections at the radio.

Record the BDAR action taken. When the mission is completed, as soon as practicable, repair vehicle using standard maintenance procedures.

## **11-22. INTERCOMMUNICATIONS SYSTEM FIELD EXPEDIENT**

### **General Information**

This procedure gives instructions for constructing field expedient intercoms.

### **Limitations**

- If the AM-1780 is non-operational, the radio systems will not be usable through the intercom.
- If telephone cable WD-1/TT is routed to the driver's station, the turret cannot be traversed without cutting the cable.

### **Personnel/Time Required**

- 1 soldier
- 10 minutes

### **Materials Tools**

- One TA-312/PT or TA-1/PT field telephone for each station where requirement for intercom exists
- Cable, telephone, W D-1/TT, 10 to 15-foot length

### **Other Option**

- Replace with Soviet R-124 intercom. (Refer to paragraph 11-28).

**CAUTION**

Do not crank or ring the field telephone because damage could occur to the AM-1780 and/or the entire AN/VIC-1 system.

**Procedural Steps:**

1. If one or more of the control boxes becomes inoperable but the AM-1780 is still operational, install TA-312 or TA-1 field telephones at the station(s) where the bad control boxes are located and run field telephone wire back to the AM-1780. The WD-1/TT should be hooked upon the "line" jacks of the AM-1780.
2. If the AM-1780 is not operational, replace the entire intercom system with TA-312 or TA-1 telephones and field telephone wire. Run the wire in a circle throughout the vehicle so that all telephones are connected to the same wire.

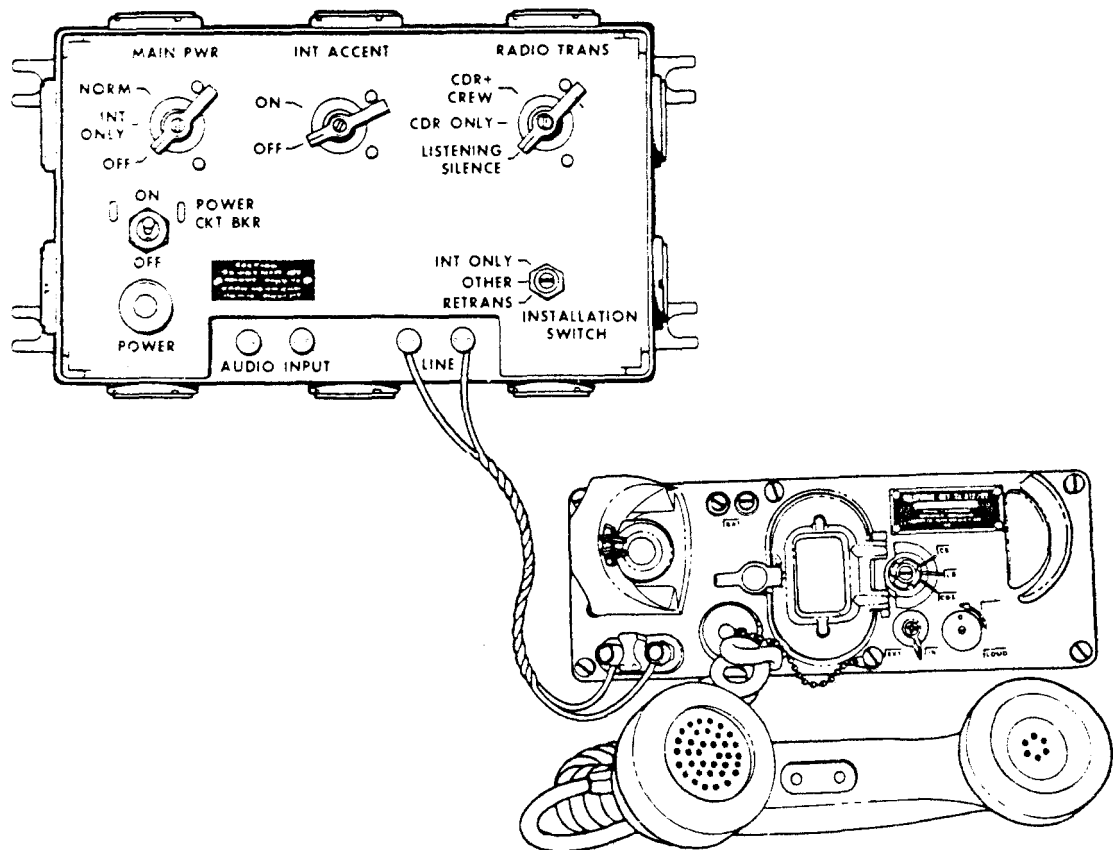

3. Record the BDAR action taken. When the mission is completed, as soon as practicable, repair vehicle using standard maintenance procedures.

**TM 9-2350-275-BD**  
**COMMUNICATIONS SYSTEM**

**11-23. RADIO SYSTEMS FIELD EXPEDIENT**

**General Information** There are no known methods of constructing a field expedient radio. It should be noted, however, that hand signals, signal flags, flashlights, telephones, and messengers can be used in place of a radio. Communications can be restored by substituting optional equipment identified below. It should also be noted that if the intercom is not fully operational and the radio is operational but will not work with the intercom, radio communications can be partially restored by connecting the CVC helmet or an H-189 handset directly to the radio. Further, if the receiver transmitter is damaged, the auxiliary receiver can be tuned to the proper frequency and used for reception only.

**Limitations:**

- Depending on extent of equipment damage or failure, partial to total loss of radio communications.

**Personnel/Time Required:**

- 1 soldier
- 30 minutes

**Materials/Tools:**

- Cable, telephone, WD-1/TT
- Field Telephone TA-312/PT, or TA-1/PT
- Flag set

**Procedural Steps:**

1. Substitute radio with:
  - a. AN/VRC-12 series on foreign equipment. (Refer to para. 11-25.)
  - b. Soviet equipment. (Refer to para. 11-26.)
  - c. Foreign Allied equipment. (Refer to para. 11-27.)
2. Record the BDAR action taken. When the mission is completed, as soon as practicable, repair vehicle using standard maintenance procedures.

**11-24. FIELD EXPEDIENT RADIO MOUNT REPAIR.**

**General Information:** Because of the configuration of plugs and jacks located on the mount and the way that the radio sets and mounts are mated, the fixes are very limited. Power and signal cables are routed in and out of the mount through cables and plugs and in turn with a plug and jack method to the radio. If any of those plugs and jacks are damaged, the only feasible alternative is to replace the mount.

**Limitations:**

- None

**Personnel/Time Required:**

- 1 soldier
- 45 minutes

**11-26**

### Procedural Steps

1. Turn off power to the radios.
2. Remove radio from damaged mount.
3. Carefully remove damaged mount from vehicle.
4. Remove all cables from damaged mount and note their positions.
5. Remove undamaged plugs from mount and reconnect them to the proper cables.
6. Check for blown fuse in mount. The fuse junction box is located on top of radio receptacle plug. Replace a blown fuse with a piece of solder or wire.

**FOR TEMPORARY FUSE  
CONNECT LENGTH OF SOLDER  
BETWEEN SCREWS**

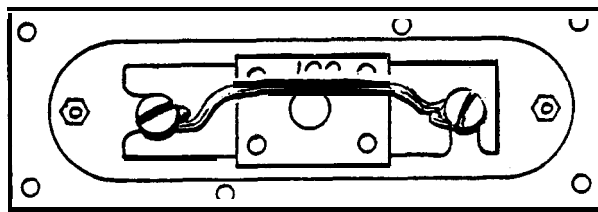

**MT-1029. Junction Box Cover**

7. Turn power on.
8. Measure voltage on J-21 (Power Cable) at terminals a (negative) and B (positive). Voltage should be between 22 and 30 VDC.
9. Turn power off.
10. Attach radio receptacle plug to radio.
11. Strap or tie down radio to prevent falling.
12. Make sure radio is grounded by connecting a wire from a screw on the radio to any convenient screw or bolt on the vehicle.
13. Turn on power and radio. Check radio for power operation.
14. Record the BDAR action taken. When the mission is completed, as soon as practicable, repair the vehicle using standard maintenance procedures.

**TM 9-2350-275-BD**  
**COMMUNICATIONS SYSTEM**

**11-25. FOREIGN EQUIPMENT INTERCHANGEABILITY (AN/VRC-12 SERIES)**

**General Information:**

This procedure contains interchangeability information to be used if standard radio components are not available.

**Limitations:**

- None

**Personnel/Time Required:**

- 1 soldier
- 15 minutes

**Materials/Tools:**

- Component, radio, AN/VRC-12 series from foreign vehicle

**Other Option(s)**

- Field expedient radio systems. (Refer to para. 11-23.)
- Replace radio with:
  1. Soviet equipment. (Refer to para. 11-26.)
  2. Foreign Allied equipment. (Refer to para. 11-27.)

**Procedural Steps:**

1. The following foreign countries use the standard AN/VRC-12 series radio which can be installed in the US model vehicles with no modifications required using standard procedures

- |            |                |
|------------|----------------|
| a. Belgium | d. Netherlands |
| b. Israel  | e. Spain       |
| c. Korea   | f. Sweden      |

2. Record the BDAR action taken. When the mission is completed, as soon as practicable, repair vehicle using standard maintenance procedures.

**11-26. FOREIGN EQUIPMENT INTERCHANGEABILITY (SOVIET RADIO R-123M)**

**General Information:**

This procedure gives installation and operating instructions for the Soviet R-123M transceiver.

**Limitations:**

- This radio cannot be wired through the AN/VIC-1 intercom. Therefore, it can only be used by one man.

**Personnel/Time Required**

- 1 soldier
- 1 hour

**Materials/Tools**

- Wire, 4-conductor, 18-gauge 5-foot length or cable, telephone, WD-1/TT, 5-foot length, (two required) (cut back three steel strands of the two sections)
- Connector, UG-273
- Handset, H-189/GR, or standard CVC helmet
- Plate, Soviet chest
- Transceiver, Soviet, R-123M (with power supply)
- Wire, 2-conductor, 12-gauge (minimum size), 3-foot length
- Rope, 10-foot length
- Gun, soldering
- Solder, rosin-core

**Other Options**

- Substitute radio with
  1. Foreign Allied equipment (Refer to para. 11-27).
  2. Foreign AN/VRC-12 series equipment. (Refer to para. 11-25.)

**Procedural Steps:**

**NOTE**

The AN/VIC-1 intercom should not have the R-123M wired through it. For proper operation of the intercom while the R-123M is being used, set the INSTALLATION SWITCH on the AM-1780 to INT ONLY position.

1. Locate the power cable that runs from the turret wall to connection J-21 on the bottom of MT-1029. Remove the cable from the J-21 connection. Without removing the connector from the cable, strip back and remove approximately four inches of the outer insulation. Stagger the splices, and scrape approximately 1/4 to 1/2-inch of the inner insulation off each of the four wires in the cable.
2. Use a jumper cable of at least 12-gauge wire, and attach both the red and the white wires in this power cable to the positive side of the Soviet power supply. (Point A.)
3. Use another jumper cable of at least 12-gauge wire, and attach both the black and the green wires in this power cable to the negative side of the power supply. (Point B.)

TM 9-2350-275-BD  
COMMUNICATIONS SYSTEM

Procedural Steps (Cont):

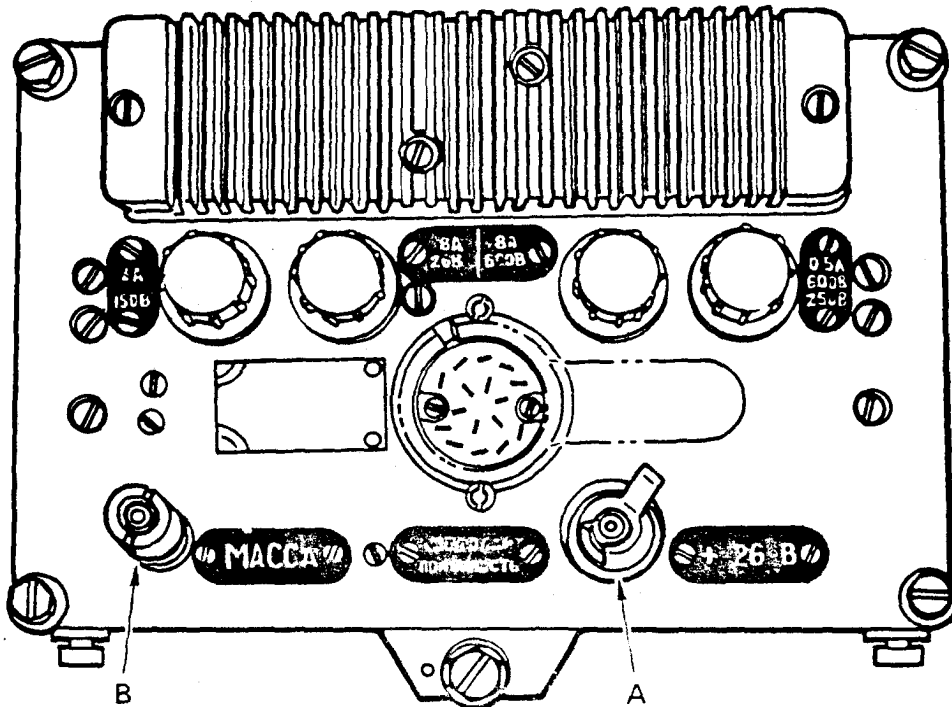

4. Install the R-123M onto the MT-1029, and tie down with rope or web sling.

5. Remove the outer cover on the female end of the UG-273 connector to make it a male connector and insert it into the antenna connection point located on the right side of the R-123M immediately below the AHTEHHA sign. Attach the RF cable.

NOTE

- o Frequency must be set manually on the MX6707. If possible use the auxiliary antenna.
- o Use the four-conductor wire to hook up either a H-189 handset or a CVC helmet to the Soviet chest plate.



**Procedural Steps (Cont):**

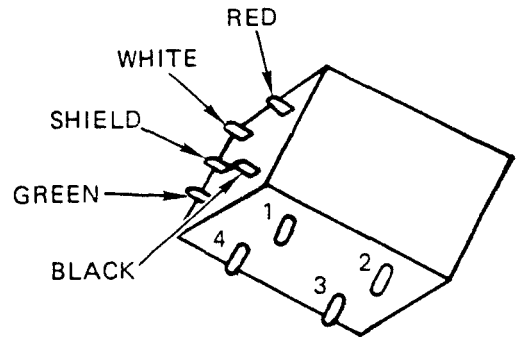
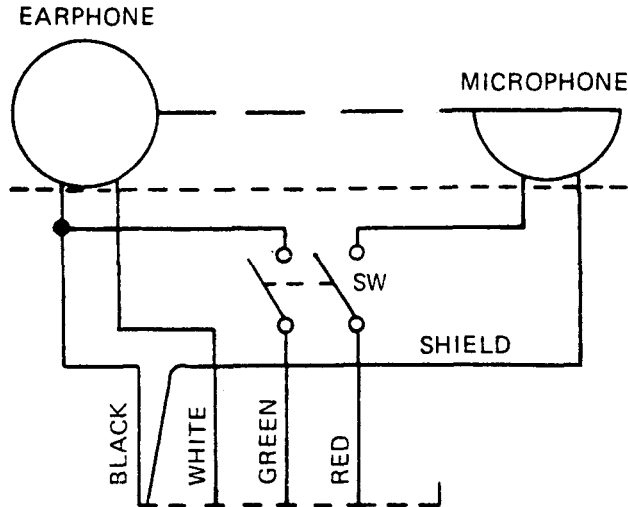

NOTE:  
BOTTOM AND END VIEW OF SWITCH

6. H-189 Handset:

a. Insert and connect the four wires through the handset to the black, white, green, and red wire connections on the switch.

b. Hook the black wire to one of the inside jacks on the Soviet chest plate and the white wire to the other inside jack. (Points A and B.)

Hook the green wire connection to one of the outside jacks and the red wire to the other outside jack (points C and D).

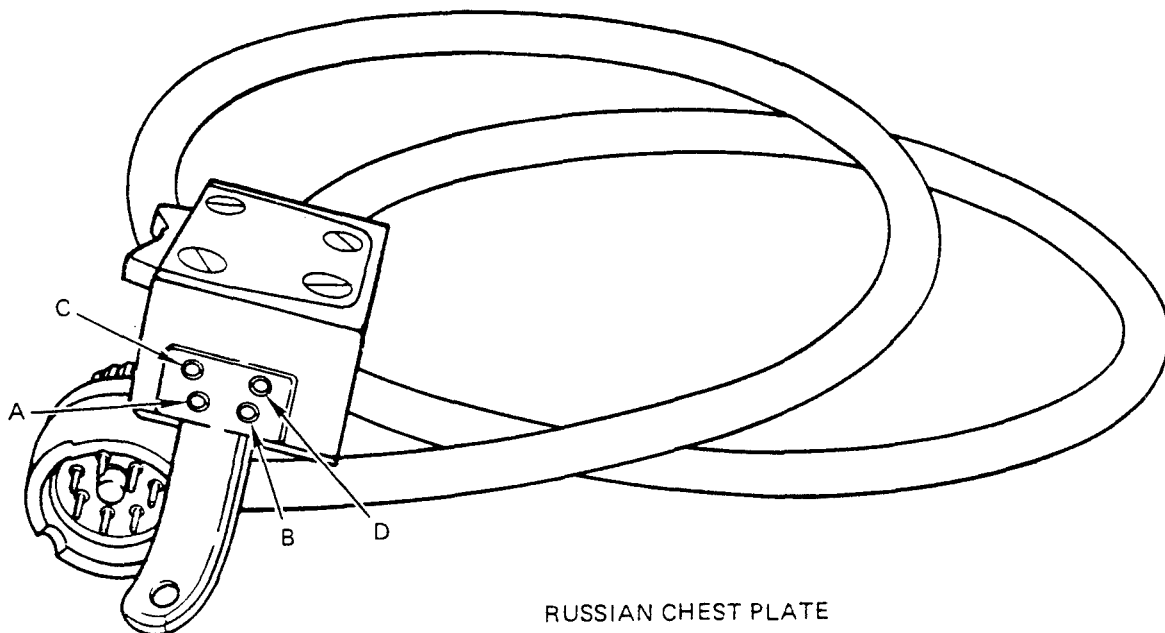

RUSSIAN CHEST PLATE

**TM 9-2350-275-BD  
COMMUNICATIONS SYSTEM**

**Procedural Steps (Cont):**

7. CVC Helmet:

a. Remove plastic earphone cushion and receiver retainer to gain access to the switch assembly.

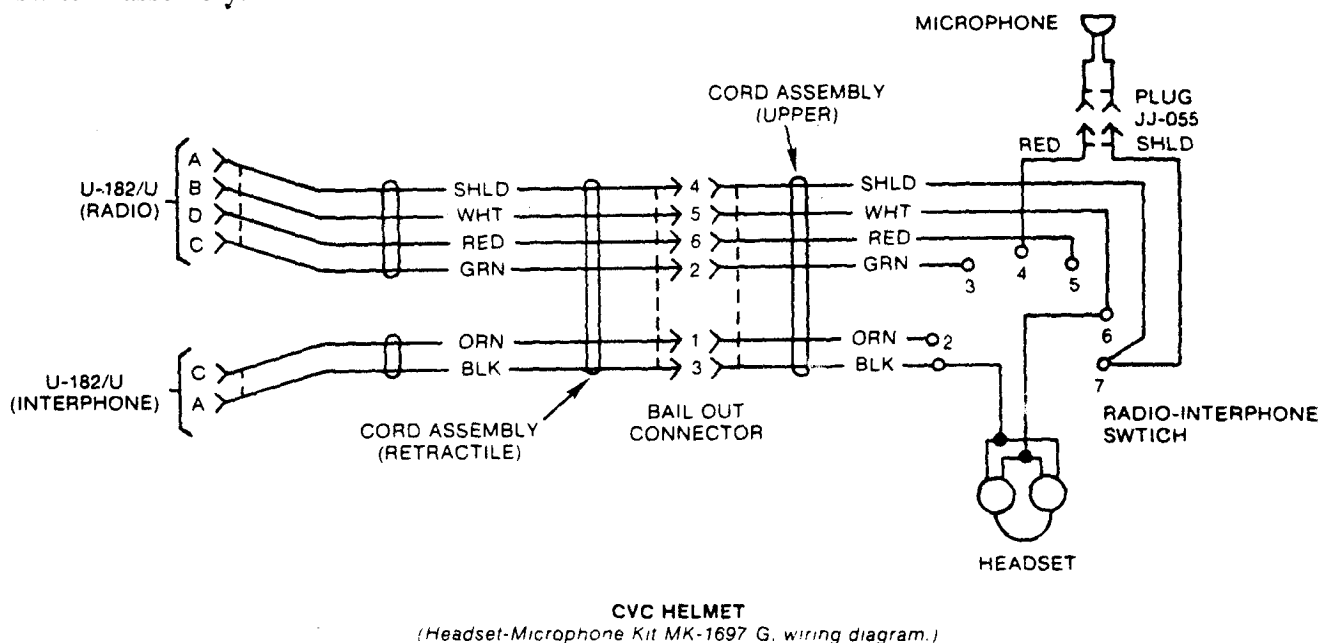

b. Connect four wires to white (switch position 6), black (1), shield (7), and red (4) wires.

c. Hook the white wire to one of the inside jacks on the Soviet chest plate and the black wire to the other inside jack (Points A and B on chest plate figure).

d. Hook the shield wire to one of the outside jacks and the red wire to the other outside jack. (Points C and Don chest plate figure).

e. Reassemble helmet. If you can receive but not transmit, reverse the red wire lead and shield wire lead on the two outside jacks.

8. Operating procedures for the Soviet R-123M Transceiver:

**NOTE**

Operating procedures and steps are keyed to the following figure.

a. Make sure the POWER SWITCH (23) and the DIAL LIGHT SWITCH (26) are in the off (down) position.

b. Set the MODE SELECTOR SWITCH (3) to the Simplex (left) position.

c. Make sure the ANTENNA LOADING CONTROL LOCKING NUT (8) is tightened (clockwise) until snug.

**Procedural Step (Cont):**

- d. Turn the SQUELCH CONTROL KNOB (2) counterclockwise (off).
- e. Turn the VOLUME CONTROL KNOB (16) all the way clockwise.
- f. Turn the VOLTAGE CHECK/OPERATE SWITCH (28) to the receiver circuits portion of the scale; 1,2B (approximately the one o'clock position).
- g. Turn the power source on. The input voltage to the R-123M power supply should be 24 + 1 vDC for best operation.

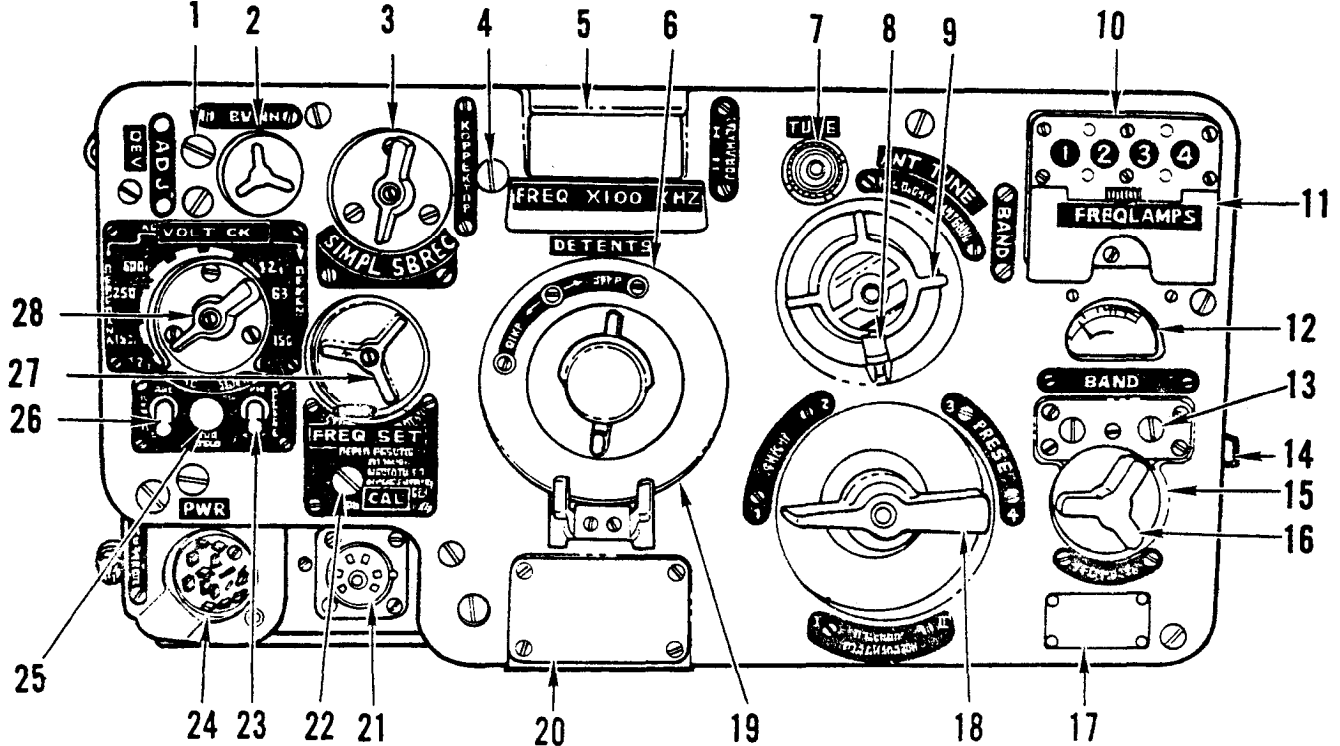

- |  |  |   |
|--|--|---|
| 1. DEVIATION ADJUSTMENT UNDER PLUG)          | 9. ANTENNA LOADING CONTROL KNOB                    | 19. PRESET LOCKING SCREW ACCESS COVER   |
| 2. SQUELCH CONTROL KNOB                      | 10. PRESET CHANNEL INDICATOR                       | 20. OPERATING FREQUENCY CARD            |
| 3. MODE SELECTOR SWITCH                      | 11. PRESET CHANNEL BAND SELECTOR (UNDER COVER)     | 21. INTERCOM CONNECTOR                  |
| 4. INDEX LINE ADJUSTMENT (UNDER PLUG)        | 12. INDICATOR METER                                | 22. CALIBRATION ADJUSTMENT (UNDER PLUG) |
| 5. FREQUENCY DIAL VIEWING WINDOW             | 13. BAND INDICATOR                                 | 23. POWER SWITCH                        |
| 6. PRESET LOCKING SCREWS (UNDER COVER (19) ) | 14. ANTENNA CONNECTOR LOCKING SCREW                | 24. POWER INPUT CONNECTOR               |
| 7. RF INDICATOR LAMP                         | 15. GROUND CONNECTOR                               | 25. TONE CALL BUTTON                    |
| 8. ANTENNA LOADING CONTROL LOCKING NUT       | 16. VOLUME CONTROL KNOB                            | 26. DIAL LIGHT SWITCH                   |
|  | 17. DATA PLATE                                     | 27. FREQUENCY TUNING KNOB               |
|  | 18. PRESET CHANNEL/CONTINUOUS TUNE SELECTOR SWITCH | 28. VOLTAGE CHECK/OPERATE SWITCH        |

- h. Turn the POWER SWITCH (23) and the DIAL LIGHT SWITCH (26) to the on (up) position. At this time the FREQUENCY DIAL VIEWING WINDOW (5) and the INDICATOR METER (12) will light. After the tubes are heated, a rushing noise will be heard in the earphones. Adjust the VOLUME CONTROL KNOB (16) for the desired volume level.

**TM 9-2350-275-BD**  
**COMMUNICATIONS SYSTEM**

**Procedural Steps (Cont):**

i. Check the power supply in the receive mode by noting the reading on the INDICATOR METER (12) and turning the VOLTAGE CHECK/OPERATE SWITCH (28) clockwise to the 6,3B and the 150B positions. The needle on the INDICATOR METER (12) should be in the shaded portion of the scale for all readings. If not in the shaded portion, check the power supply for bad fuses and replace any bad ones.

**CAUTION**

The receiver and transmitter are tuned simultaneously. Do not operate the transmitter without using an antenna or dummy load. Transmitting into an antenna base without connecting an antenna may damage the transmitter portion of the radio.

j. Check the power supply in the transmit mode by placing the VOLTAGE CHECK/OPERATE SWITCH (28) to the 1,2B position on the transmitter circuits portion of the scale (approximate y the 7 o'clock position). The INDICATOR METER (12) should read in the shaded portion of the scale. If not in the shaded portion, check the power supply for bad fuses and replace any bad ones.

k. Place the VOLTAGE CHECK/OPERATE SWITCH (28) in the 150B position by rotating the switch clockwise. Momentarily place the chest plate switch and the CVC helmet or H-189 switch in the transmit position. Note the reading on the INDIATOR METER (12); it should be in the shaded portion of the scale. Release the switches.

l. Place the VOLTAGE CHECK/OPERATE SWITCH (28) alternately in the 250B and 600B positions by rotating the switch clockwise. To obtain an indication, it is necessary to momentarily depress the switches to transmit. Both the readings should be in the shaded portion of the scale.

m. Place the VOLTAGE CHECK/OPERATE SWITCH (28) in the operate #1 PABOTA 1) position.

n. Place the PRESET CHANNEL/CONTINUOUS TUNE SELECTOR SWITCH (18) in either the I or 11 position. Position I will be used if the desired operating frequency is between 20 and 35.75 MHZ and position II will be selected if the desired operating frequency will be between 35.8 to 51.5 MHZ. Band selections are also shown by the BAND INDICATOR (13) lights.

To calibrate the FREQUENCY DIAL, rotate the FREQUENCY TUNING KNOB (27) while looking into the FREQUENCY DIAL VIEWING WINDOW (5) and select the frequency listed below that is the closest to the desired operating frequency.

Band I: 22.050 MHZ 28.350 MHZ 34.650 MHZ  
Band II: 36.225 MHZ 40.950 MHZ 42.525 MHZ 45.675 MHZ 48.825 MHZ

The frequencies are noted on the frequency dial with an extended graduation line capped by an arrowhead.

**Procedural Steps (Cont):**

p. Set the MODE SELECTOR SWITCH (3) to the receive only (right) position.

q. Depress and hold the TONE CALL BUTTON (25). A tone should be heard in the earphones. Rotate the FREQUENCY TUNING KNOB (27) until a zero beat is obtained. While rotating the FREQUENCY TUNING KNOB (27) the tone should be heard to progress from a high pitch to a low pitch then to a high pitch again. The proper setting of the FREQUENCY TUNING KNOB (27) is the point at which the tone is at its lowest pitch or totally absent.

Note the relative positions of the index line and the frequency graduation line through the FREQUENCY DIAL VIEWING WINDOW (5). If the index line is within 1/5 of a frequency graduation (5 KHZ), no adjustment of the index line is necessary. Proceed after releasing the TONE CALL BUTTON (25). If the index line is not within 1/5 of a graduation (5 KHZ) the following adjustments must be made:

(1) Release the TONE CALL BUTTON (25). Using a screwdriver, remove the INDEX LINE ADJUSTMENT (4) plug.

**NOTE**

This adjustment is quite stiff. Care should be exercised to not change the frequency setting while adjusting the index line.

(2) Insert the screwdriver into the hole disclosed and contact the index line adjustment. Rotate the adjustment right or left until the index line exactly corresponds to the selected frequency graduation line.

(3) Replace the INDEX LINE ADJUSTMENT (4) plug.

(4) Check the setting by repeating steps (q) and (r). When no adjustment is required, proceed to the next step.

s. Return the MODE SELECTOR SWITCH (3) to the Simplex position (left).

t. Set the PRESET CHANNEL/CONTINUOUS TUNE SELECTOR SWITCH (18) to the preset #1 position.

u. Set the PRESET CHANNEL BAND SELECTOR (11) to correspond with the desired band. Frequencies between 20.0 and 35.75 MHZ are set on Band I (switch up); frequencies between 35.8 and 51.5 HMZ are set on Band II (switch down). Band selections are indicated by the BAND INDICATOR lights (13).

v. Open the PRESET LOCKING SCREW ACCESS COVER (19) on the front panel and loosen the PRESET LOCKING SCREW (6) marked "1" by turning the locking screw counterclockwise until the slot is at right angles with the red circle. To release the preset locking screw, use the special key (not shown) attached to the case of the radio.

**TM 9-2350-275-BD**  
**COMMUNICATIONS SYSTEM**

**Procedural Steps (Cont):**

w. Turn the FREQUENCY TUNING KNOB (27) to the desired frequency by aligning the desired frequency with the indicator line within the FREQUENCY DIAL VIEWING WINDOW (5). While holding the FREQUENCY TUNING KNOB (27) turn the PRESET LOCKING SCREW (6) clockwise with the special key until it is aligned with the red circle.

x. Loosen the ANTENNA LOADING CONTROL LOCKING NUT (8) two or three turns counterclockwise.

y. Put the chest plate switch in the transmit position and hold. Turn the ANTENNA LOADING CONTROL KNOB (9) for maximum deflection on the INDICATOR METER (12) and maximum brilliance on the RF INDICATOR LAMP (7).

**NOTE**

Several peaks will be noted on the indicator meter while loading the antenna. Tune to the maximum peak and to the maximum brilliance on the indicator lamp. For a more sensitive meter to help choose between peaks, turn the VOLTAGE CHECK/OPERATE SWITCH (28) to the Operate #2 (PAbOTA 2) position. After determining the most advantageous loading position, return the VOLTAGE CHECK/OPERATE SWITCH (28) to the operate # 1 (PAbOTA 1) position. Release the chest plate switch.

z. While holding the ANTENNA LOADING CONTROL KNOB (9), tighten the ANTENNA LOADING CONTROL LOCKING NUT (8). Check this step by depressing the chest plate switch to the transmit position. If the indication on the INDICATOR METER (12) is not the same as noted in step (y), loosen the ANTENNA LOADING CONTROL LOCKING NUT (8) and repeat step (y). If proper loading has been accomplished release the chest plate switch and proceed.

aa. Repeat steps (s) through (w) to preset frequencies on settings 2, 3, and 4.

**NOTE**

Only two frequencies can be preset on Band I and two more can be preset on Band 11. Example: If the PRESET CHANNEL BAND SELECTOR (11) is set at Band I position for preset #1 and #2, only Band II frequencies can be selected for presets #3 and #4. Any combination of bands and presets may be used.

ab. You are now ready to operate in the preset mode. Any time you want to select a preset frequency, simply turn the PRESET "CHANNEL/CONTINUOUS TUNE SELECTOR SWITCH (18) to the desired preset number.

**Procedural Steps (Cont):**

ac. To operate in the continuous tune mode, turn the PRESET CHANNEL/CONTINUOUS TUNE SELECTOR SWITCH (18) to the lower positions, labelled I and II. "I" corresponds to Band I frequencies and "II" corresponds to Band II frequencies.

ad. the FREQUENCY TUNING KNOB (27) to the desired frequency.

ae. Load the antenna by accomplishing steps (w) thru (z).

**CAUTION**

Observe a 1:3 transmit to receive ratio i.g., 3 minutes transmit to 9 minutes receive, to minimize the possibility of overheating the power supply and power output tubes.

af. You are now ready to operate in the continuous tune mode. The tuning controls are very sensitive; therefore, the continuous mode should not be selected if the radio is to be moved or subjected to vibrations.

9. Record the BDAR action taken. When the mission is completed, as soon as practicable, repair vehicle using standard maintenance procedures.

**11-27. FOREIGN EQUIPMENT INTERCHANABILITY (ALLIED RADIOS)**

**General Information**

This procedure contains general installation instructions for Allied radio equipment.

**Limitations**

- Vary according to radio set but you can expect a decrease in operating range on some sets.
- You can expect not to be able to transmit and receive on all frequencies within the U.S. AN/VRC-12 frequency range.

**Personnel/Time Required**

- 1 soldier
- Approximately one hour for each type of installation

**Other Options**

- Replace with the AN/VRC-12 series of radio components from foreign vehicles. (Refer to para. 11-25.)
- Replace with Soviet radio R-123M. (Refer to para. 11-26.)

**Procedural Steps**

1. Refer to table 11-1 for comparison purposes in determining limitations.

**TM 9-2350-275-BD**  
**COMMUNICATIONS SYSTEM**

Procedural Steps (Cont):

Table 11-1. Allied Radios

Basic FM Radio & Country	Frequency Range (MHz)	Power Output		Bandwidth (KHz)	Range (km)	
		Min	Max		Min	Max
AN/VRC-12	30 to 75.95	3	35	50	8	30
PRC-351/352 (UK)	30 to 75.95	4	20	25/50	8	16
SEM-35/25 (FRG)	26 to 69.95	0.15	15	50	8	30
RV-3/13/V (Italy)	26 to 71.95		15	50		30
TR-VP-113/213 (France)	26 to 71.95		15	50		30
TRC-570 (France)	26 to 71.95	2	30	25/50	15	40

**NOTE**

The Allied countries listed in the table have agreed to utilize the same connectors for cables within the radio system. All power cable connectors should be the same regardless of which country's radio is examined.

2. Remove the radio and its accompanying mount from the foreign vehicle. Note which cable connector supplies power to the mount.
- 30 Remove the radio and its accompanying mount from your vehicle. Note that the power cable is 3-21.
4. Install the foreign vehicle radio and mount in the place vacated by the U.S. AN/VRC-12.
5. Install the cable that previously ran to J-21 in the connector socket for input power on the foreign radio mount.
6. If the foreign vehicle had an intercom system, hook up the cable that runs between J-22 on the U.S. radio mount and 3-501 on the AM-1780. This cable must be connected to the same connections to which the foreign vehicle intercom master control box was connected to.
7. Be sure to take one foreign vehicle CVC helmet for use in case the U.S. CVC helmet will not adapt to the front of the foreign radio. Prior to using the foreign CVC helmet at the radio face, attempt to operate the radio through the AM-1780. If the AM- 1780 does not key the foreign radio then there is a wiring difference and the foreign CVC helmet can be connected directly to the microphone connector on the front face of the foreign radio.



**Procedural Steps (Cont):**

8. Record the BDAR taken. When the mission is completed, as soon as practicable, repair vehicle using standard maintenance procedures.

**11-28. FOREIGN EQUIPMENT INTERCHANGEABILITY (SOVIET INTERCOM R-124)**

**General Information:**

This procedure gives installation and operating instructions for the Soviet R-124 intercom.

**Limitations:**

● The AN/VRC-12 series radio cannot be wired through this intercom. Therefore, the radio can only be operated by one man.

**Personnel/Time Required:**

- 1 soldier
- 1 hour

**Materials/Tools:**

- Handset, H-189/6R, (each chestplate), or standard CVC helmet
- Intercom, Soviet, R-124
- Plate, chest, Soviet (one for each control box)
- Tape, electrical
- Wire, 4-conductor, 18-gauge, 5-foot length or cable, telephone, W D-1/TT, 5-foot length (two required)
- Wire 2-concor 12-gauge 3 foot length
- Gun, soldering
- Solder, rosin-core

**Other Option:**

- Field expedient intercom (refer to para. 11-22).

**Procedural Steps:**

**NOTE**

All wires in the R-124 interconnecting cables are soldered directly to the internal connecting points in the individual boxes. Use care in removal/installation. Do not disconnect individual boxes unless absolutely necessary.

1. Remove the R-124 from Soviet vehicle and install in U.S. vehicle.
2. Wire the H-189/GR handset or CVC helmet using the procedures listed in para. 11-26.

**NOTE**

Power is obtained in the same manner as listed in step 1 of para. 11-26.

3. Attach the red and white wires from the power cable to the black terminal on the bottom of the A-1 box of the R-124. Attach the black and green wires from the power cable to the ground strap on the A-1 box. See position 6 in the illustration on the following page.

**TM 9-2350-275-BD  
COMMUNICATIONS SYSTEM**

**Procedural Steps (Cont)**

4. Operating procedures for the R-124.

**NOTE**

Operating procedures are keyed to the intercom.

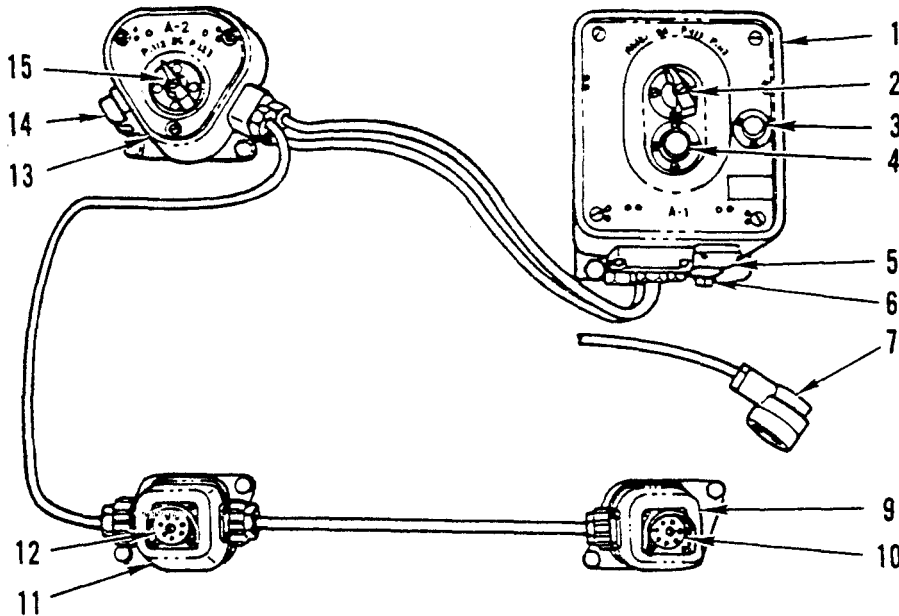

- |                             |                            |
|-----------------------------|----------------------------|
| 1. A-1 MAIN JUNCTION BOX    | 9. A-4 TERMINATING BOX     |
| 2. FUNCTION SWITCH          | 10. CVC RECEPTACLE         |
| 3. FUSE                     | 11. A-3 INTERCONNECTING BC |
| 4. VOLUME CONTROL           | 12. CVC RECEPTACLE         |
| 5. CVC RECEPTACLE           | 13. A-2 CONTROL BOX        |
| 6. VOLTAGE CONNECTION POINT | 14. CVC RECEPTACLE         |
| 7. R-112 CONNECTION CABLE   | 15. FUNCTION SWITCH        |
| 8. R-123 CONNECTION CABLE   |                            |

a. Connect the CVC helmet to the chest plate switch. Connect the chest plate switch to any of the R-124 receptacles (5, 10, 12, or 14 in the intercom figure).

b. Set FUNCTION SWITCH (2) and FUNCTION SWITCH (15) to the intercom BC position. (Both function switches must be in the BC position to allow all four boxes access to intercom.)

c. Adjust VOLUME CONTROL (4) for desired audio level in the headsets.

5. Record the BDAR action taken. When the mission is completed, as soon as practicable, repair tank using standard maintenance procedures.

## 11-29. COAXIAL CABLE REPAIR

### General Information

This procedure gives instructions and identifies materials recommended for repair of coaxial or other shielded cables when standard replacement parts are not available.

### Limitations:

- None

### Personnel/Time Required

- 1 soldier
- 20 minutes

### Materials/Tools:

- See illustrations in this procedure for materials required.

### Other Option:

- See shielded cable repair procedures in electrical chapter of TM 9-2350-276-BD.

### Procedural Steps:

#### NOTE

Do not attempt to repair broken or damaged coaxial cables unless absolutely necessary. Replace the entire cable whenever possible.

1. If replacement is not practical, install a matching plug and jack of the proper size and type for splicing the damaged or broken part.

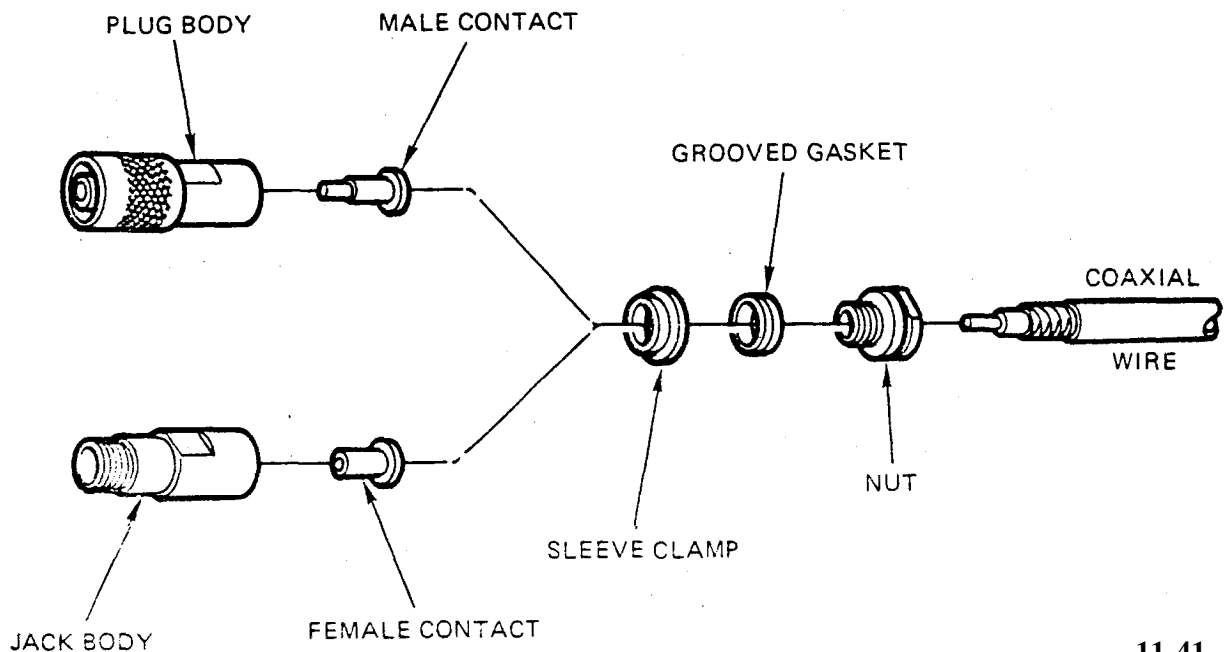

**TM 9-2350-275-BD  
COMMUNICATIONS SYSTEM**

**Procedural Steps (Cont):**

2. Alternate repair to coaxial cables. Damage to coaxial cable shields or the center conductors can be repaired using the same methods as any other shielded wire repair. Insure that this repair is sufficiently insulated to prevent the center conductor from shorting to the shield. The shielding may be restored by several methods. One such method is illustrated below.

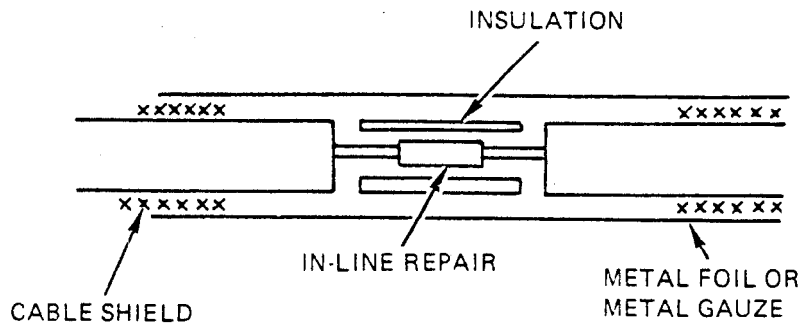

a. Remove 1/2 inch of insulation from the shielding and join the severed ends of the shielding together by wrapping a conductive material over the repair. Some suitable materials are tubular copper braid, metal gauze, conductive foil from gum wrappers, cigarette packages or common kitchen foil.

b. Remove one inch of insulation, unravel exposed shielding, and twist into pigtails. Join the pigtails by splicing in a piece of insulated wire. Insulate the entire repair when using either method of repair.

3. Record the BDAR action taken. When the mission is complete, as soon as practicable, repair vehicle using standard maintenance procedures.

**11-30. INTERCOMMUNICATIONS CABLE REPAIR**

**General Information**

This procedure gives methods for connecting broken wires in multiple wire cables such as the CX-4723 intercommunications cables.

**Limitations**

- None

**Personnel/Time Required**

- 1 soldier
- 5-10 minutes per individual wire

**Materials/Tools:**

- Knife
- Tape
- Soldering iron
- Solder, rosin-core

**Other Option:**

- See other methods for splicing wires and cables in the electrical chapter of TM 9-2350-276-BD.

**Procedural Steps:**

1. Turn off power or unplug cable at both ends if possible or at end nearest the damaged area.
2. Peel back outside insulation about 3 inches on each side of damaged area.
3. Identify wires with broken insulation only and those with actual separated wires.
4. Tape those with broken insulation but with wire intact.
5. Cut clean ends on broken wires.
6. Strip insulation back 1/2 inch.
7. Matching color coding on wires, twist together, solder if possible, or tighten with pliers if available.
8. Bend twisted wires back along length of wire.
9. Tape repaired wire with length of tape.
10. When all wires are repaired, tape around entire bundle and try to seal insulation ends peeled back in Step 2.
11. Plug cable back into equipment, turn on power, and test.
12. Record BDAR action taken, when the mission is complete, as soon as practicable, repair vehicle using standard maintenance procedures.

**11-31. CABLES ARE TOO SHORT; BDAR INSTALLATION**

**General Information**

This procedure gives methods for connecting two or more cables together to make the desired cable length. This procedure is for CX-4723 cable. Other types of cables can be extended using similar methods.

## **TM 9-2350-275-BD COMMUNICATIONS SYSTEM**

### **Limitations:**

- Preferred method - none
- Alternate methods - possible lowered volume

### **Personnel/Time Required:**

- 1 soldier
- 20 minutes

### **Materials/Tools:**

- Preferred method  
Box, control, C-10456 or C-2298 VRC
- Alternate method:  
Gun, soldering  
Solder, rosin-core

### **Other Options:**

- See other methods for splicing cables in electrical chapter.
- The preferred method uses a junction box such as a C-2298 control box between two CX-4723 cables.
- Another method is f abdicating a junction by removing the 3-801 and 3-804 connectors from a C-2298 control box. Solder jumper wires between the corresponding connector pins. Insulate the jumper wires and the rear of the connectors.
- A less desirable method is to remove one connector from each cable and splice the corresponding wires from the two cables together. Insulate the splice.

Record the BDAR action taken. When the mission is complete, as soon as practicable, repair vehicle using standard maintenance procedures.

## **11-32. ISOLATION OF NON-ESSENTIAL SYSTEMS (GENERAL)**

### **General Information:**

This procedure lists general guidelines for the isolation of non-essential systems.

### **Limitations:**

- Varies depending on which system is isolated

### **Personnel/Time Required**

- 1 soldier
- 5-30 minutes

### **Materials/Tools**

- Crimp-on end caps, electrical tape or other insulating material

**Other Options:**

- Insulate/isolate non-essential wiring or cabling with crimp-on end caps, tape, or any other insulating material. Secure wires to some structure and tag them for rapid identification.
- Any intercom control box can be considered non-essential if one is willing to operate without it. Disconnect the cable leading to that particular control box at AM-1780 and consider using field expedient means for intercom. Also, consider switching control boxes and/or cables within the vehicle to provide intercom at the desired points. For repairs of this type, existing cabling can be rerouted if the original cables have been damaged.

Record the BDAR action taken. When the mission is complete, as soon as practicable, repair vehicle using standard maintenance procedures.

**11-33. ISOLATION OF NON-ESSENTIAL SYSTEMS (VOLTAGE SUPPRESSORS)**

**General Information**

This procedure gives instructions for the isolation and by-passing of both the MK 2096 and the MX-7777/MX-7778 Transient Voltage Suppressors.

**Limitations**

- Possible loss of all communications

**Personnel/Time Required:**

- 1 soldier
- 5-10 minutes

**Procedural Steps:**

**CAUTION**

Without the transient voltage suppressor in the circuit, voltage spikes will be routed through the communications equipment and damage could occur. Bypass the suppressor only as a last resort.

1. Removal of MK-2096 transient voltage suppressor:
  - a. Locate the MK-2096 under the radio mount.
  - b. Unscrew the MK-2096 from the connector.
  - c. The MK-2096 is now removed from the circuit.

**TM 9-2350-275-BD**  
**COMMUNICATIONS SYSTEM**

Procedural Steps (Cont):

2. Removal of MX-7777/MX-7778 transient voltage suppressor:
  - a. Locate the MX-7777/MX-7778 in the vicinity of the driver's compartment.
  - b. Remove the CX-10613/G cable which runs between the vehicle power receptacle and the rear of the voltage suppressor.
  - c. Remove the Bendix connector which is attached to one of two possible plugs on the top of the suppressor.
  - d. Plug this Bendix connector directly into vehicle power receptacle.
  - e. The suppressor is now out of the circuit.

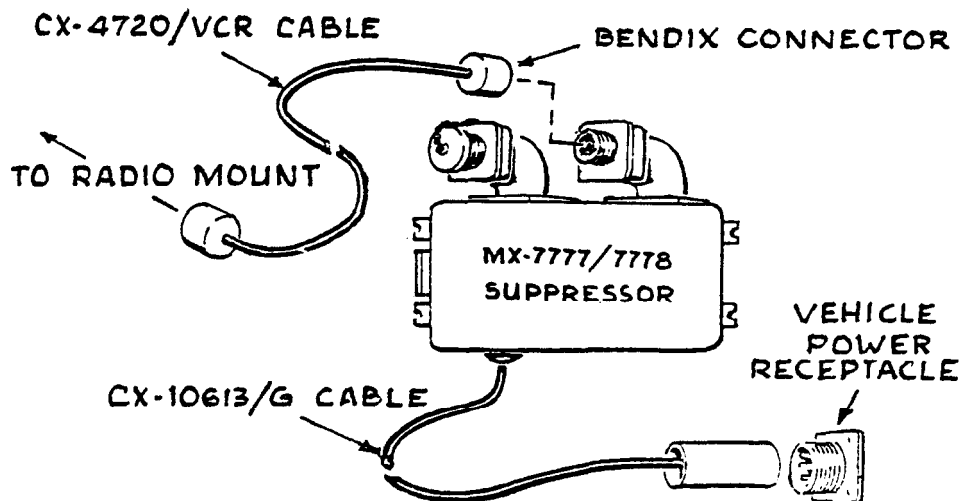

Record the BDAR action taken. When mission is completed, as soon as practicable, repair tank using standard maintenance procedures.



## 11-34. FIELD EXPEDIENT RADIO REMOTE

### General Information:

This procedure gives instructions for the construction of a field expedient remote to replace the AN/GRA-39 if it is inoperative.

### Limitations:

- None

### Personnel/Time Required:

- 1 soldier
- 60-90 minutes

### Materials/Tools:

- 680 Ohm Resistor
- 47 Ohm Resistor
- 5000 Ohm Variable Potentiometer
- H-144/U Handset (only cord and plug used)
- M-80 Microphone (only cord and plug used)
- K-1 Relay (28 VDC) (NSN: 5945-00-951-6458)
- BA4386/U Battery (NSN: 6135-00-926-8322)
- TA-312/PT Field Telephones (two each)
- Electrical tape
- 18-24 Gauge wire
- Soldering iron and solder
- Wire strippers
- Multimeter or continuity tester
- Knife
- WD-1/TT field wire (as needed)

### Procedural Steps:

1. Build the prototype radio remote unit from the schematic using the following steps:
  - a. Locate the R-3 potentiometer, K-1 relay, and BA4386/U battery. Tape the three components solidly together.
  - b. Cut the cords from the H-144/U handset and the M-80 microphone.

**TM 9-2350-275-BD  
COMMUNICATIONS SYSTEM**

**Procedural Steps (Cont):**

**NOTE:**

Cut as close to the handset and microphone as possible so a long cord and the plug will be intact.

- c. Strip 6 inches of outer insulation off the cut end of each of the cords, being careful not to cut the inner wires.
- d. Strip 1/2 inch of insulation off the end of each of the exposed wires.
- e. Use the multimeter or continuity tester to match the wires with the pins in the plug using referenced letters.
- f. Solder the two resistors.
- g. Solder the wires to points referenced.
- h. Solder the remaining wires using the 18-24 gauge wire.

**NOTE**

When connecting the wires to the battery plug, ensure they are connected as shown.

Pin 6 on K-1 relay is not used. Pin C on battery connector is not used. Pins C, D, E, G, I, K, J, and L on the U-77 connectors are not used.

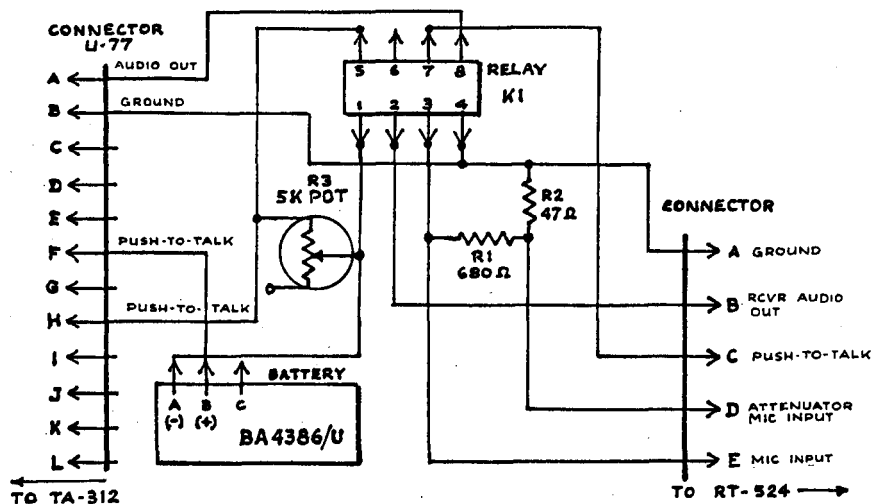

**Procedural Steps (Cont):**

2. Plug the 5-pin connector into the RT-524 jack marked RETRANSMIT R/W.
3. Plug the lo-pin connector into the receptacle on the Number 2 TA-312.
4. Cut the required length of WI)-I/TT Field Wire (up to 15 miles).
5. Connect one end of the wires to line jacks 1 and 2 of TA-312 Number 2 and the other end to line jacks 1 and 2 of TA-312 Number 1.
6. Set the selector switch S 1 on both telephones to LB to enable DC switching from the push-to-talk switch.
7. Connect the DC plug from the remote unit into the BA4386/U battery.
8. Turn on all power.
9. Adjust the 5K ohm potentiometer so that the K-1 relay in the remote unit energizes when the press-to-talk switch on TA-312 Number is pressed.
10. Once this setting is found, the potentiometer should be backed off slightly to minimize battery drain.
11. Check all connections and test.
12. Record BDAR action taken. When the mission is complete, as soon as practicable, repair the vehicle using standard maintenance procedures.

**11-35. GENERAL INTERCHANGEABILITY INFORMATION**

**General Information:**

Repairs made to combat damaged equipment should be the same as repairs made during the normal maintenance posture. However, due to the extreme nature of damage that might be found in combat-damaged equipment, normal maintenance procedures might not be sufficient. In the interest of rapidly repairing damage to communications system in this situation, it will often be faster to exchange some components rather than repair them. The following is a partial listing of interchangeable parts for the AN/VIC-1 and the AN/VRC-12 as installed in most common tracked vehicles on the battlefield. It is provided as a guide only and is not necessarily a complete listing of all components from other vehicles that could be substituted. Further assistance can be obtained by studying the cording diagrams located in paragraph 11-36. This table considers only US equipment. For information on foreign equipment interchangeability, refer to paragraph 11-25 through 11-28. Any component that has been replaced should be turned in for repair through the normal channels and thereby returned to the inventory. When time permits, route all replaced cables to conform to the original configuration. If haste is essential, route replaced cables as necessary and secure them where possible to prevent damage to the cables.

**EQUIPMENT INTERCHANGEABILITY LISTING**

<u>Nomenclature</u>	<u>Description</u>	<u>Compatible Component</u>	<u>Compatible Vehicle</u>	<u>Notes</u>
1. ANTENNAS				
AS-1729	N/A	AS-1729	All with radio	2
AS-1729	N/A	Auxiliary Antenna	All with Aux. Receiver	1
AT-1095	Top Element	AT-1095	All with radio	2
AT-1730	Bottom Element	AS-1730	All with radio	2
Auxiliary Antenna	N/A	AT-1095	All with radio	2
Auxiliary Antenna	N/A	Auxiliary Antenna	All with Aux. Receiver	2
MS-116A	Bottom Element	MS-116A	All with Aux. Receiver	2
MS-117A	Middle Element	MS-117A	All with Aux. Receiver	2
MS-118A	Top Element	MS-118A	All with Aux. Receiver	2
MX-6707	Matching unit	AT-912	Some with radio	3
AT-912	Matching unit	MX-6707	Most with radio	3
AB-15	Mast Base	AB-538	Most with Aux. Receiver	2
AB-558	Mast Base	AB-15	Most with Aux. Receiver	2

**EQUIPMENT INTERCHANGEABILITY LISTING (CONT)**

<u>Nomenclature</u>	<u>Description</u>	<u>Compatible Component</u>	<u>Compatible Vehicle</u>	<u>Notes</u>
<b>2. INTERCOM</b>				
AM-1780	Amplifier	AM-1780	AH w/AN/VIC-1	2
C-2296	Outside Control Box	C-2296	M60, M551 AVLB, MAB	2
C-2297	Drivers Control Box	C-2297	M60, M551 AVLB, MAB	2
C-2298	Member Control Box	C-10456	M1, M2, M3	2
C-2298	Member Control Box	C-2298	All w/AN/VIC/1	2
C-2742	Frequency Selector Box	C-2742	All w/RT-246	2
C-10456	Control Box	C-10456	M1, M2, M3	2
C-10456	Control Box	C-2298	All w/AN/VIC- 1	1,7
<b>3. CABLES</b>				
CG-1773	4'0"	CG-1773	M113, M88	2,5
CG-1773	5'0"	CG-1773	M151, M2, M3	2,5
CG-1773	6'0"	CG-1773	M60, M578	2,5
CG-1773	6'6"	CG-1773	M561	2,5
CG-1773	7'0"	CG-1773	M60, M151	2,5
CG-1773	8'0"	CG-1773	AVLB, M2, M3	2,5
CX-4720	2'0"	CX-4720	MAB, M561	2,5
CX-4720	3'0"	CX-4720	M151, M561	2,5
CX-4720	4'0"	CX-4720	M113	2,5

**TM 9-2350-275-BD  
COMMUNICATIONS SYSTEM**

**EQUIPMENT INTERCHANGEABILITY LISTING (CONT)**

<u>Nomenclature</u>	<u>Description</u>	<u>Compatible Component</u>	<u>Compatible Vehicle</u>	<u>Notes</u>
CX-4720	8'0"	CX-4720	M110	2,5
CX-4720	10'0"	CX-4720	AVLB	2,5
CX-4721	2'6"	CX-4721	M551 M113, M151	2,5
CX-4721	3'0"	CX-4721	M1, M561	2,5
CX-4722	4'0"	CX-4721	M2, M3	2,5
CX-4722	3'0"	CX-4722	M113	2,5
CX-4722	4'0"	CX-4722	M88	2,5
CX-4722	5'0"	CX-4722	M2, M3	2,5
CX-4722	6'0"	CX-4722	M60, M561	2,5
CX-4722	7'0"	CX-4722	M151, M578	2,5
CX-4722	8'0"	CX-4722	M2, M3	2,5
CX-4722	20'0"	CX-4722	M901	2,5
CX-4723	2'0"	CX-4723	M551, M561 MAB	2,5
CX-4723	3'0"	CX-4723	M60, M551 M2, M3, MAB	2,5
CX-4723	4'0"	CX-4723	M901, M109	2,5
CX-4723	4'6"	CX-4723	M561 M1, M2, M3, M88 M113, M901, M561,	2,5
CX-4723	5'0"	CX-4723	M551, M577, AVLB	2,5
CX-4723	6'0"	CX-4723	AVLB	2,5

**EQUIPMENT INTERCHANGEABILITY LISTING (CONT)**

<u>Nomenclature</u>	<u>Description</u>	<u>Compatible Component</u>	<u>Compatible Vehicle</u>	<u>Notes</u>
CX-4723	7'0"	CX-4723	M1, M2 M3, M110	2,5
CX-4723	8'0"	CX-4723	M2, M88, M110 M151, MAB	2,5
CX-4723	9'0"	CX-4723	M60, M88, M113, M577, M578, M901	2,5
CX-4723	10'0"	CX-4723	M60, MAB M88, M578	2,5
CX-4723	12'0"	CX-4723	M3	2,5
CX-4723	13'0"	CX-4723	M88	2,5
CX-4723	14'0"	CX-4723	M551	2,5
CX-4723	15'0"	CX-4723	M2, M109	2,5
CX-4723	16'0"	CX-4723	M60, M901	2,5
CX-4723	18'0"	CX-4723	M110	2,5
CX-4723	20'0"	CX-4723	M1, M60	2,5
CX-4723	21'0"	CX-4723	M1	2,5
CX-7058	2'0"	CX-7058	M60	2,5
CX-7058	4'0"	CX-7058	M561	2,5
CX-7058	5'0"	CX-7058	M113	2,5
CX-7058	8'0"	CX-7058	M1, M551	2,5
CX-7058	9'0"	CX-7058	M551	2,5
CX-7059	9'0"	CX-7059	M60	2,5

EQUIPMENT INTERCHANGEABILITY (CONT)

<u>Nomenclature</u>	<u>Description</u>	<u>Compatible Component</u>	<u>Compatible Vehicle</u>	<u>Notes</u>
CX-7059	10'0"	CX-7059	M151	2,5
CX-7059	22'0"	CX-7059	M1	2,5
CX-7060	1'6"	CX-7060	M1, M60	2,5
CX-7060	2'0"	CX-7060	M60	2,5
CX-7060	3'0"	CX-7060	M2, M3, M60, M110, M578	2,5
CX-7060	4'0"	CX-7060	M1, M2, M60	2,5
CX-7060	6'0"	CX-7060	M110	2,5
CX-7060	9'0"	CX-7060	M2, M3	2,5
CX-7060	14'0"	CX-7060	M3, M578	2,5
CX-8650	Y Cord	CX-8650	All w/AN/VIC-1	2,6
CX-9640	1'6"	CX-9640	M109	2,5
CX-9640	2'6"	CX-9640	M109	2,5
CX-13089	2'1"	CX-13089	M109	2,5
CX-13089	3'0"	CX-13089	M88	2,5
CX-13089	7'0"	CX-13089	M2, M3	2,5
CX-13089	10'0"	CX-13089	M578	2,5



**EQUIPMENT INTERCHANGEABILITY LISTING (CONT)**

<u>Nomenclature</u>	<u>Description</u>	<u>Compatible Component</u>	<u>Compatible Vehicle</u>	<u>Notes</u>
SC-D-866547	10'0"	SC-D-866-547	MI	2,5
SC-D-866551	8'2"	SC-D-866551	MI	2,5
4. CVC HELMETS				
CVC	MK-1039	DH-132	Most with AN/VIC-1	2,6
DH-132	MK-1697	CVC	Older Vehicles w/AN/VIC-1	2,6
5. MOUNTS				
MT-1029	Radio	MT-1029	All with radio	2,8
MT-1898	Aux Receiver	MT-1898	All with Aux. Receiver	2,8
MT-3823	KY-38	MT-3823	All w/KY-38	2
MT-4626	KY-57	MT-4626	All w/KY-57	2
AM-2060	RTB-841	AM-2060	All w/RT841	2
6. RADIO EQUIPMENT				
RT-246	Receiver Transmitter	RT-246, RT-524, RT-841	All with radio	2,9
RT-524	Receiver Transmitter	RT-246, RT-524, RT-841	All with radio	2,9
RT-841	Receiver Transmitter	RT-246, RT-524, RT-841	All with radio	2,9
R-442	Auxiliary Receiver	R-442	All with Aux. Receiver	2,9

**TM 9-2350-275-BD  
COMMUNICATIONS SYSTEM**

**EQUIPMENT INTERCHANGEABILITY LISTING (CONT)**

<u>Nomenclature</u>	<u>Description</u>	<u>Compatible Component</u>	<u>Compatible Vehicle</u>	<u>Notes</u>
<b>7. TRANSIENT VOLTAGE SUPPRESSORS</b>				
MK-2096	Mini-Suppressor	MK-2096	M1,M2,M3	2
MX-7777, MX-7778	Suppressor	MK-2096 MX-7777 MX-7777	All w/AN/VIC-1	2
<b>8. SPEECH SECURITY EQUIPMENT</b>				
AM-4979	Amplifier	AM-4979	M113	2
J-2731	Distribution Box	J-2731	M113, M60 M577, M578, M88	2
J-3024	Interconnecting Box	J-3024	M88, M113, M577, M578, M60	2
KY-38	SSE	KY-38	All w/KY-38	2
KY-57	SSE	KY-57	All w/KY-57	2
Z-ACD( )	Power Unit	Z-ACD( )	All w/KY-38	2
<b>9. SSE CABLES FOR KY-38</b>				
CX-10475	1'7"	CX-10475	M60	2,5
CX-10475	4'0"	CX-10475	M113, M88, M577, M578	2,5
CX-10475	10'0"	CX-10475	M113	2,5
CX-10539	4'0"	CX-10539	M113, M48, M577	2,5
CX-10539	6'0"	CX-10539	M113, M60	2,5
CX-11996	6'0" x 3'0"	CX-11996	M88	2,5
CX-11996	12'0" x 3'0"	CX-11996	M48, M60	2,5

**EQUIPMENT INTERCHANGEABILITY LISTING (CONT)**

<u>Nomenclature</u>	<u>Description</u>	<u>Compatible ComDonent</u>	<u>Compatible Vehicle</u>	<u>Notes</u>
CX-11996	14'0" x 3'0"	CX-11996	M60, M113	2,5
CX-11996	10'0" x 5'0"	CX-11996	M577, M578, M113	2,5
CX-12126	5'0"	CX-12126	M113	2,5
CX-12126	8'0"	CX-12126	M113	2,5
CX-12195	4'0"	CX-12195	M578, M88 M113, M577	2,5
CX-12195	6'0"	CX12195	M113, M48	2,5
CX-12195	10'0"	CX-12195	M60	2,5
CX-12925	6'0"	CX-12925	M113	2,5
Power Cable	Y	Power Cable	All w/KY-38	2

**NOTES**

- NOTE #1      System is slightly degraded. Replace with original component as soon as possible.
- NOTE #2      No degradation. Continue normal mission.
- NOTE #3      No degradation, electronically compatible; however, adapter bracket may have to be locally fabricated as AT-912 may not bolt into same holes. Also, antenna element AT-1096 must be used in lieu of antenna element AS-1730.
- NOTE #4      This precludes usage of RT-524 and should not be done unless RT-524 is inoperative.
- NOTE #5      Any cable with the same number can be substituted if it is of an equal length to or longer than the cable being replaced. Most of the time a shorter cable can also be used by routing it in the most direct path between components. Additionally, two shorter cables can be spliced together to attain the desired length.

**TM 9-2350-275-BD  
COMMUNICATIONS SYSTEM**

**NOTES (Cont):**

- NOTE #6      Ensure the connector comparability. If the older type CVC helmet is substituted for the DH-132 series helmet then the cord assembly CX-8650 B/GR must also be exchanged with the CVC-helmet.
- NOTE #7      This exchange will remove the capability to key the intercom or radio by any means other than by the switch located on the CVC helmet.
- NOTE #8      If the mount is from any vehicle other than a vehicle with the AN-VIC-1 intercom then the "Pivot terminal link" must be in position as shown. .

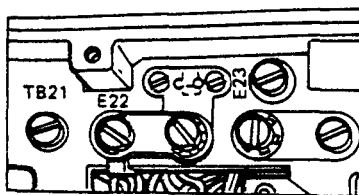

- NOTE #9      If the R/T or aux receiver is from a vehicle not utilizing speech security equipment then the X-mode position switch may have to be changed. Turn your R/T ON and see below procedures.
- A      Set the R/T SQUELCH control on OLD ON.
  - B      Remove the cover from the X-MODE receptacle, if the CALL light comes on, the switch is in X-MODE, BUT if the CALL light does not come on, the switch is in NORMAL. Organizational or higher maintenance should then:
  - C      Remove R/T from out, turn R/T upside down.
  - D      Remove bottom cover from R/T.
  - E      Loosen assembly A 4000 captive screws.
  - F      Raise assembly A 4000 and lock brace.
  - G      Turn X-MODE-NORMAL switch to X-MODE.
  - H      Be sure leaf springs are equally curved.
  - I      Lower assembly A 4000 and tighten captive screws.
  - J      Be sure assembly hinge pin is pushed all the way in.
  - K      Replace bottom cover of R/T.
  - L      Replace R/T on to mount.

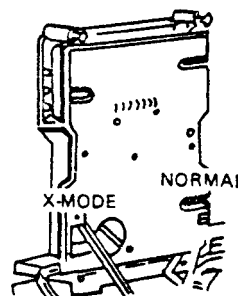

**NOTE (Cont)**

If the AUX receiver is to be used in the X-MODE communications hookup, it must be opened up and its switch set to X-MODE.

The AUX receiver switch must be placed in NORMAL after you are through with the X-MODE hook-up.

NOTE #10 - Loss of automatic channel selection if RT-246 is being used.

**Section V. Common Vehicle Cording Diagrams**

**11-36. GENERAL.**

Cording diagrams for common U.S. vehicles on the battlefield have been provided in this section to aid in identifying components and cables that are interchangeable. These diagrams also assist in identifying cables without having to trace them throughout the vehicle.

<u>Cording Diagram For:</u>	<u>Page</u>
KY-57 General Configuration (Unclassified)	11-61
AN/VIC-1 and AN/VRC-12 in M 1 Tank	11-62
AN/VRC-46, AN/VRC-64, or two AN/GRC-160's with AN/VIC-1 in M2 (chassis)	11-63
AN/VRC-46, AN/VRC-64 or (two) AN/GRC-160's with AN/VIC-1, in M3 (chassis)	11-63
AN/VRC-46, AN/VRC-64 or (two) AN/GRC-160's with AN/VIC-1, in M2 and M3 (turret)	11-64
AN/VIC-1 and AN/VRC-12 in M60A1 Tank	11-65
AN/VRC-46, AN/VRC-64, or AN/GRC-160 with AN/VIC-1 in M88A1	11-66
AN/VRC-46, AN/VRC-53, AN/GRC-125, AN/VRC-64, or AN/GRC-160 and AN/VIC-1 in M578	11-67
AN/VIC-1 in M 113 and M577	11-68
AN/VRC-12 in M 113 Family	11-68
AN/GRC-160 and AN/VIC-1 in Improved Tow Vehicle M901	11-69
	<b>11-59</b>

**TM 9-2350-275-BD, COMMUNICATIONS SYSTEM**

AN/VIC-1 in M109A2 and M109A3	<b>11-70</b>
AN/VIC-1 in M107 or 8-in M110.	<b>11-70</b>
AN/VRC-12 in 1/4-ton M151A1	<b>11-71</b>
AN/VIC-1 in Mobile Floating Assault Bridge/Ferry	<b>11-71</b>
AN/VRC- 12 and AN/VIC-1 in AVLB (M60 chassis)	<b>11-72</b>
AN/VRC-12 or AN/VRC-47 in M561.	<b>11-72</b>
AN/VIC-1 in M561 Commo Vehicle with I/C Equipment in Cab or in Rear	<b>11-73</b>

KY-57 General Configuration

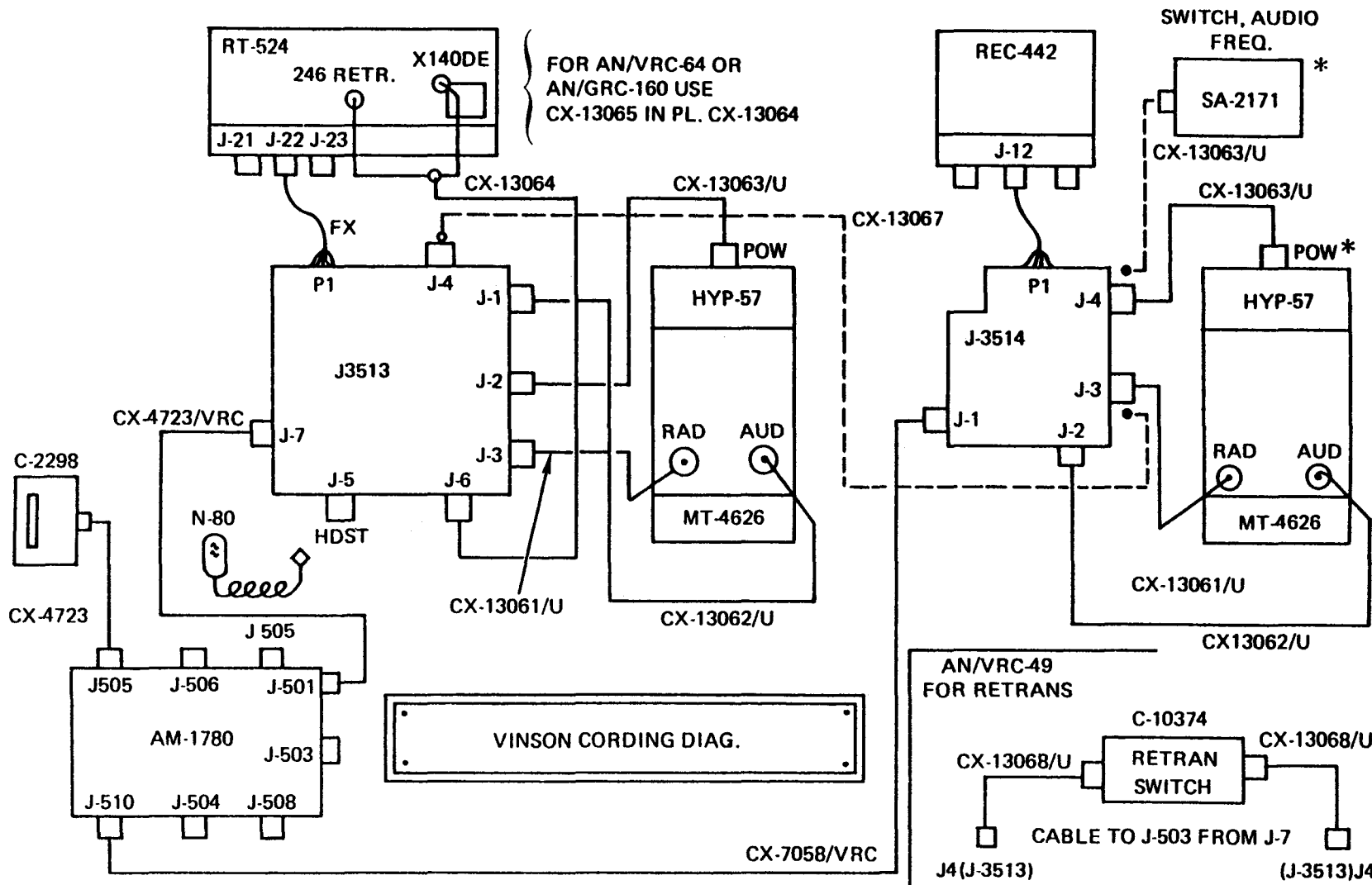

\*THIS 2ND KY-57 NOT USED - 1ST KY-57 IS SPARED

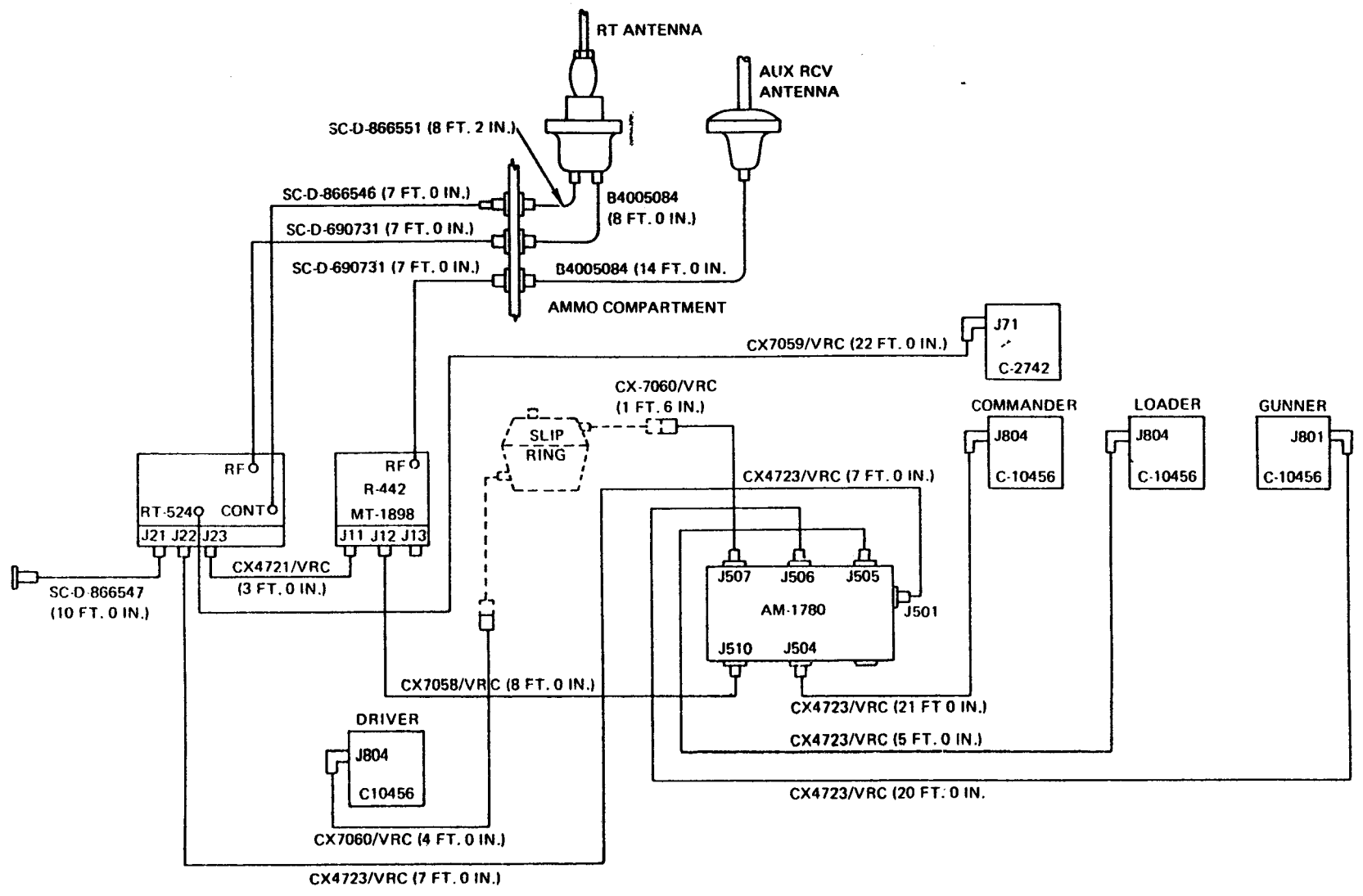

AN/VIC-1 and AN/VRC-12 in M1 Tank



**TM 9-2350-275-BD  
COMMUNICATIONS SYSTEM**

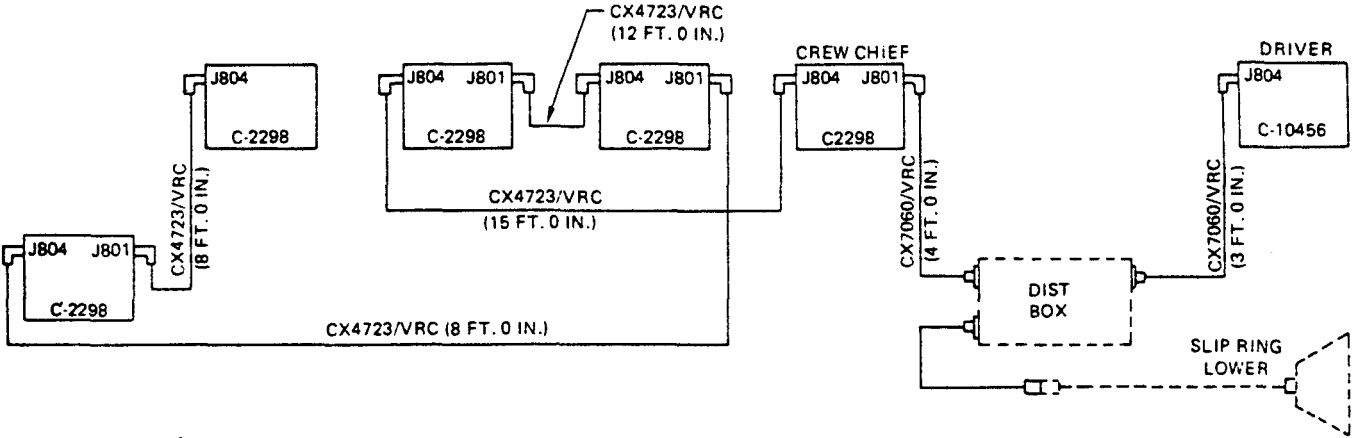

**AN/VRC-46, AN/VRC-64, or Two AN/GRC-160's with AN/VIC-1 in M2 (chassis)**

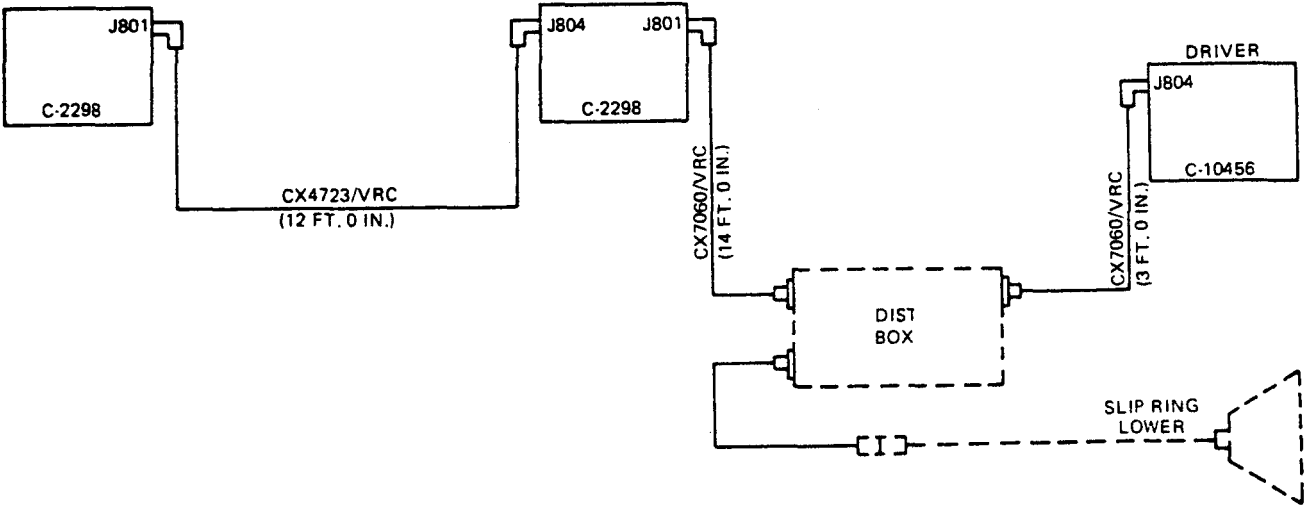

**AN/VRC-46, AN/VRC-64, or Two AN/GRC-160's with AN/VIC-1 in M3 (chassis)**

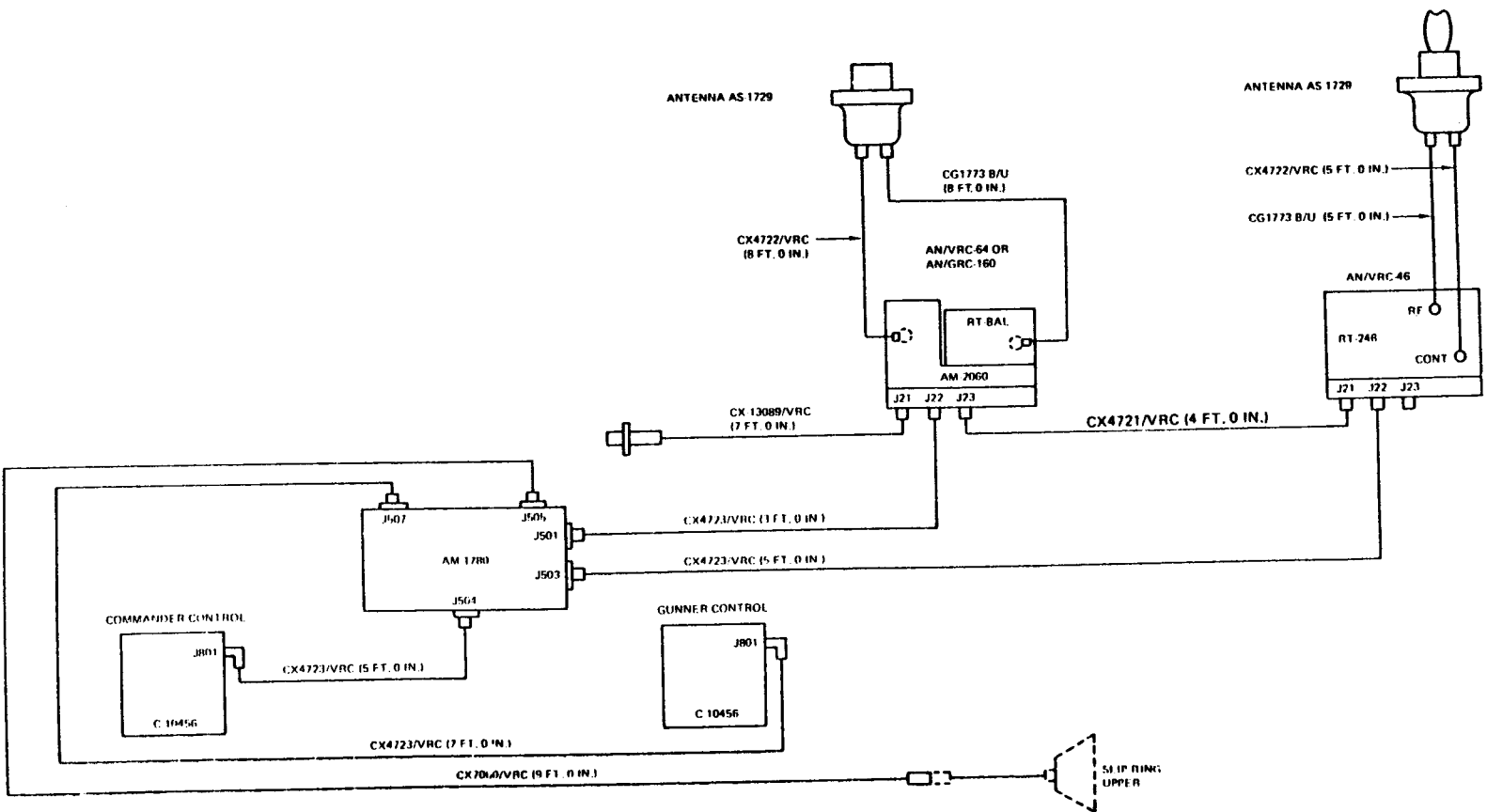

AN/VRC-46, AN/VRC-64, or Two AN/GRC-160's with AN/VIC-1 in M2 and M3  
(Turret)

AN/VIC-1 and AN/VRC-12 in M60A1 Tank

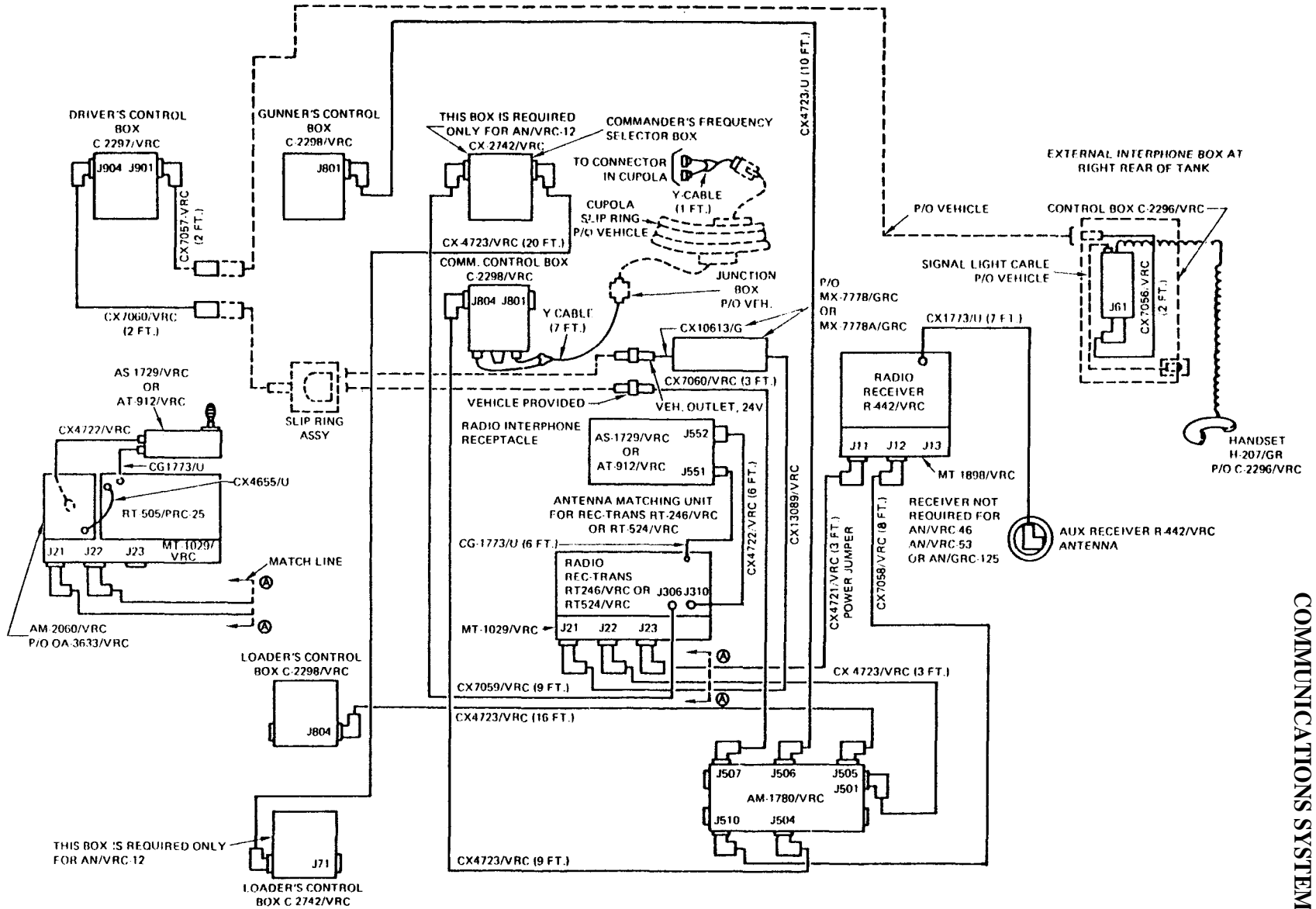

TM 9-2350-275-BD COMMUNICATIONS SYSTEM

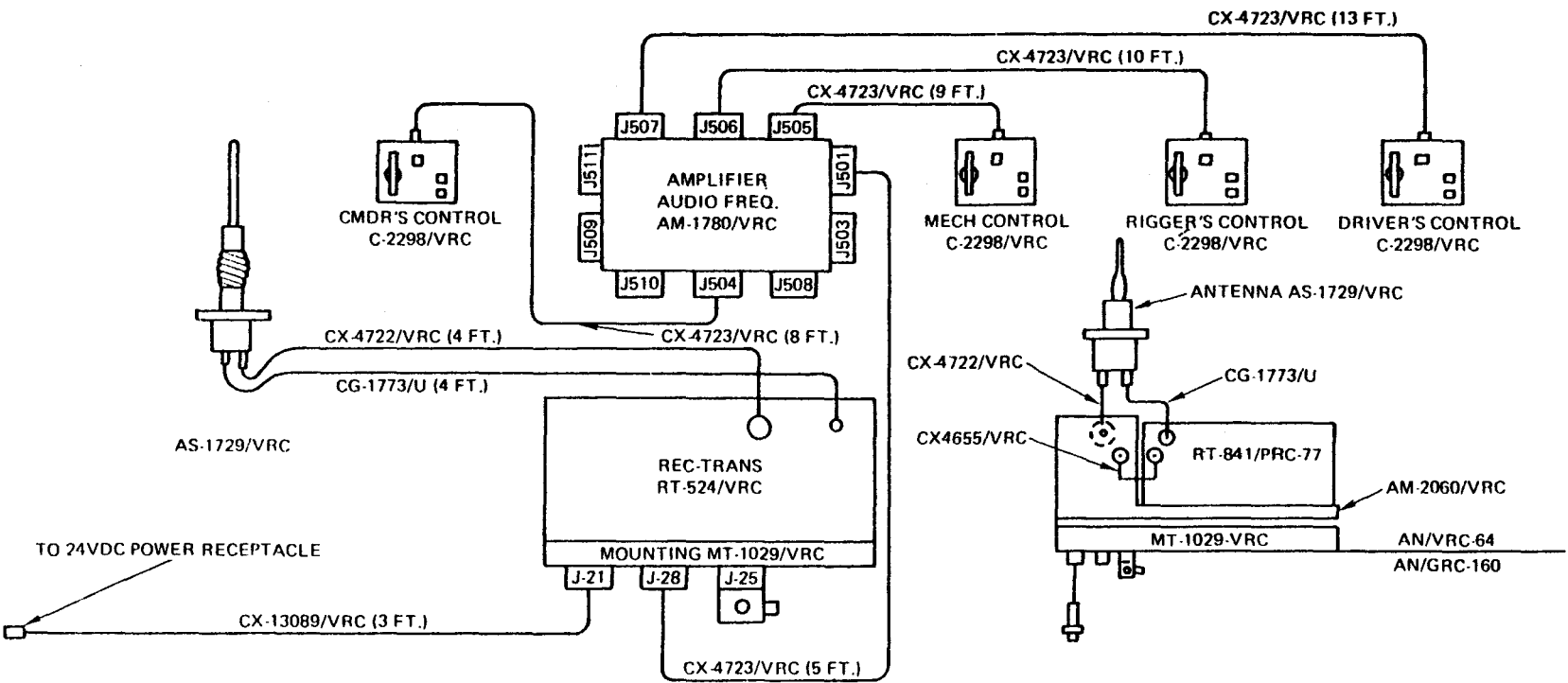

AN/VRC-46, AN/VRC-64, or AN/GRC-160 with AN/VIC-1 in M88A1

AN/VRC-46, AN/VRC-53, AN/VRC-59, AN/VRC-64 OR AN/VRC-64 OR AN/VRC-160, AN/GRC-125, AN/GRC-125, AN/GRC-160 and AN/VIC-1 in M578

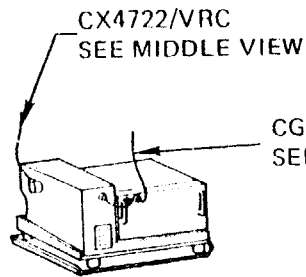

CG1773/U  
SEE MIDDLE VIEW

AN/VRC-59  
AN/GRC-125  
AN/VRC-64 OR  
AN/GRC-160

CX4723/VRC  
R/T TO AM-1780/VRC

CX7060/VRC (3 FT.)

C2298/VRC

CX4722/VRC (7 FT.)  
R/T TO RF AMPLIFIER

CG1773/U (6 FT.)  
R/T TO RF AMPLIFIER

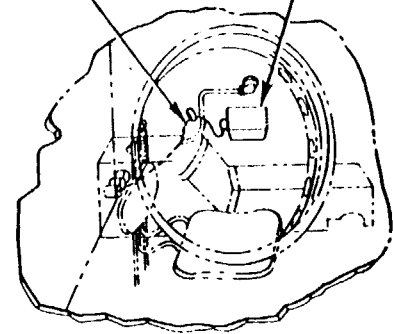

FRONT OF VEHICLE  
DRIVER'S LOCATION IN HULL

CX4723/VRC (10 FT.)

CG1773/U  
FROM R/T  
CX4722/VRC  
FROM R/T

CX7060/VRC (14 FT.)  
FROM SLIP RING

CX4723/VRC (9 FT.)  
FROM CAB RIGGER LOCATION  
C2298/VRC

CX13089/VRC (10 Ft.)  
POWER CABLE

CX4723/VRC (9 FT.)  
FROM R/T TO AM-1780/VRC

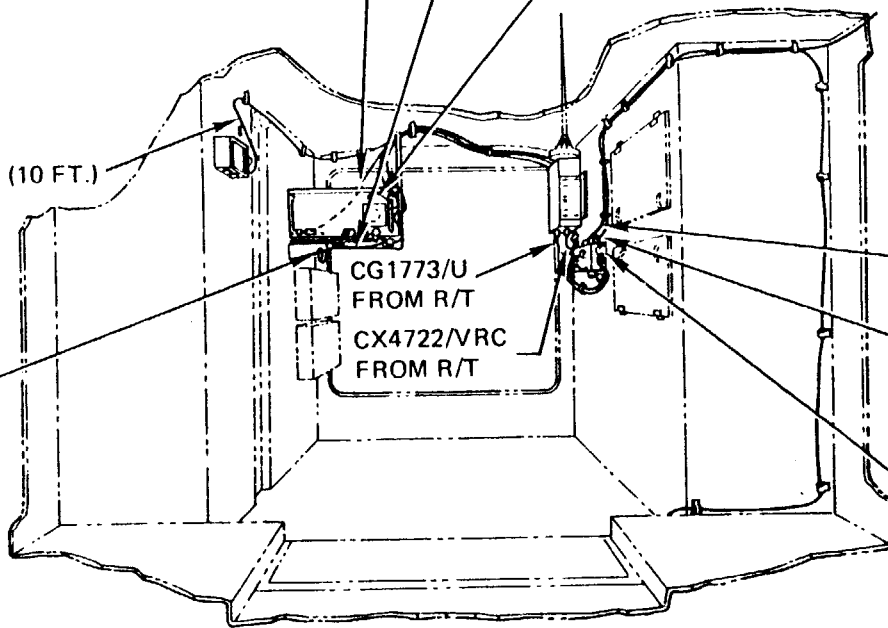

FRONT  
OF  
VEHICLE

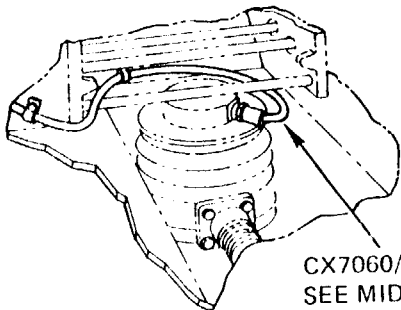

CX7060/VRC  
SEE MIDDLE VIEW

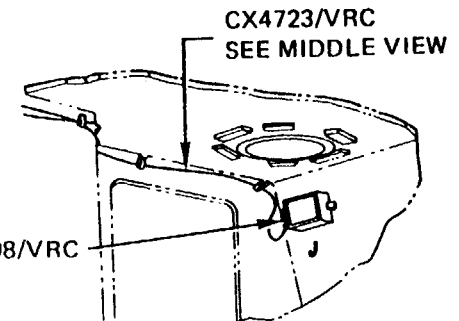

FRONT OF VEHICLE  
RIGGER'S LOCATION IN CAB

TM 9-2350-275-BD  
COMMUNICATIONS SYSTEM

TM 9-2350-275-BD  
COMMUNICATIONS SYSTEM

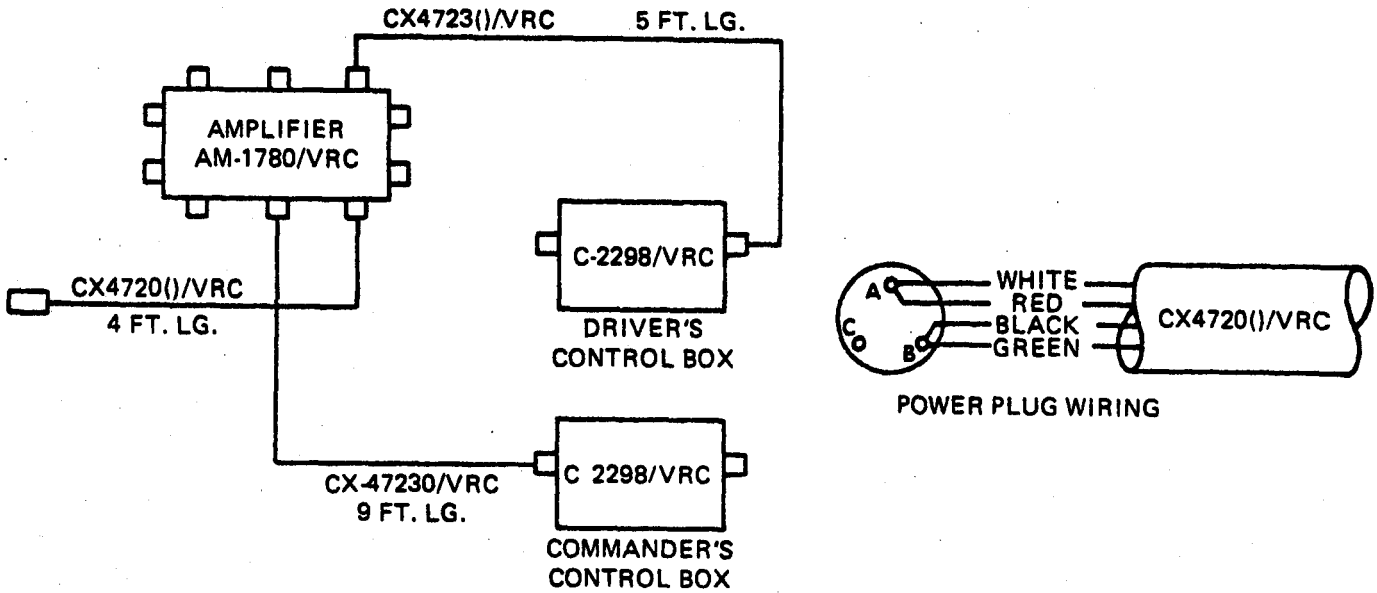

AN/VIC-1 in M113 and M577

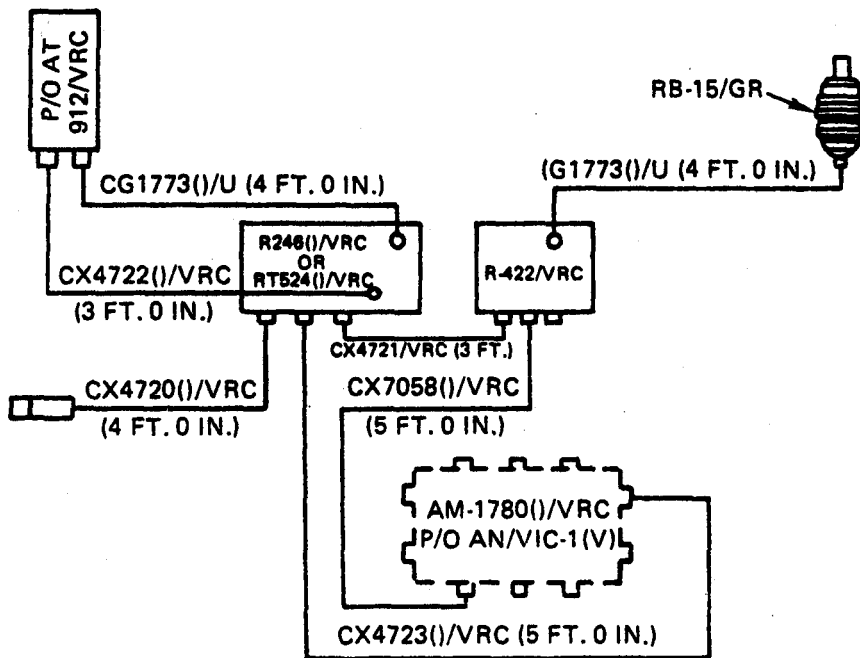

(CORDS MUST ENTER AM-1780()/VRC AS SHOWN)

AN/VRC-12 in M113 Family

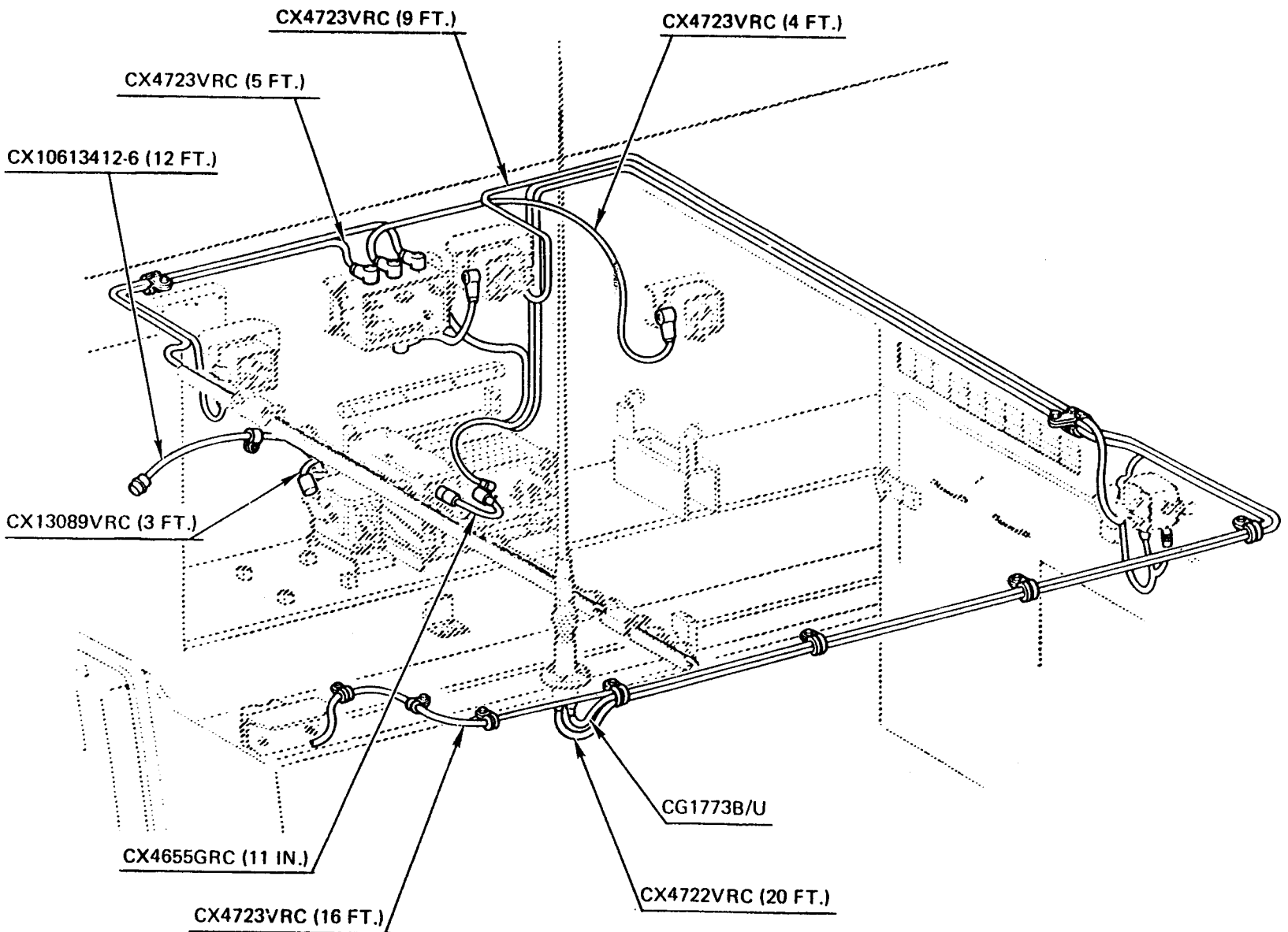

AN/GRC-160 and AN/VIC-1 in Improved TOW Vehicle M901

TM 9-2350-275-BD  
COMMUNICATIONS SYSTEM

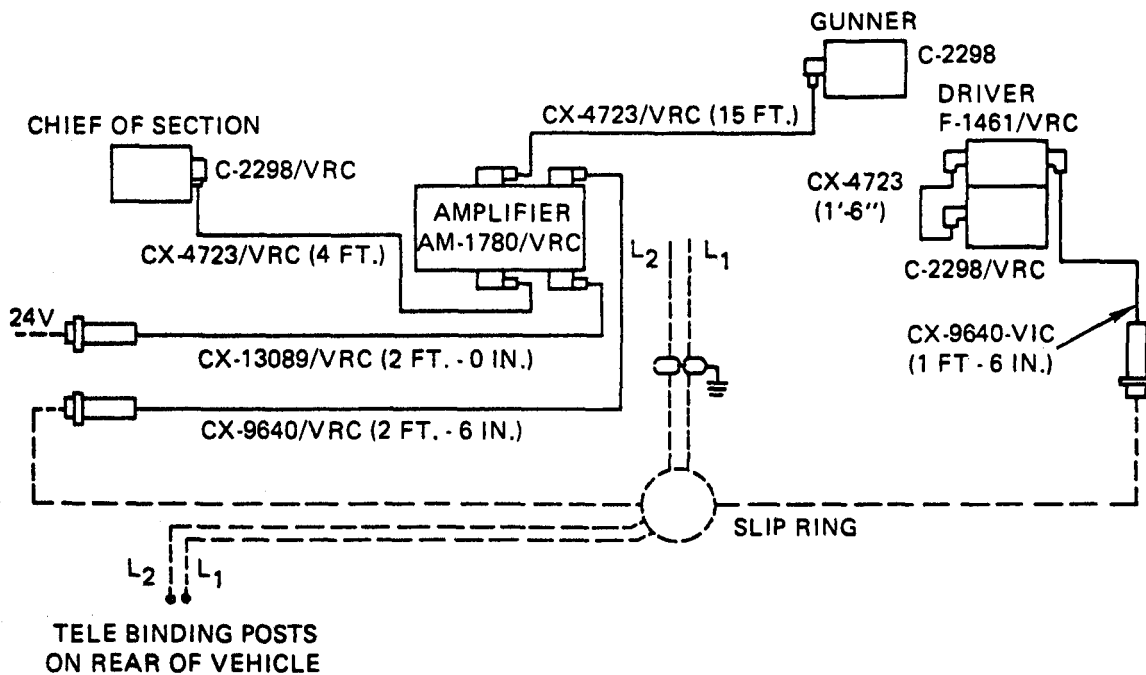

AN/VIC-1 in M109A2 and M109A3

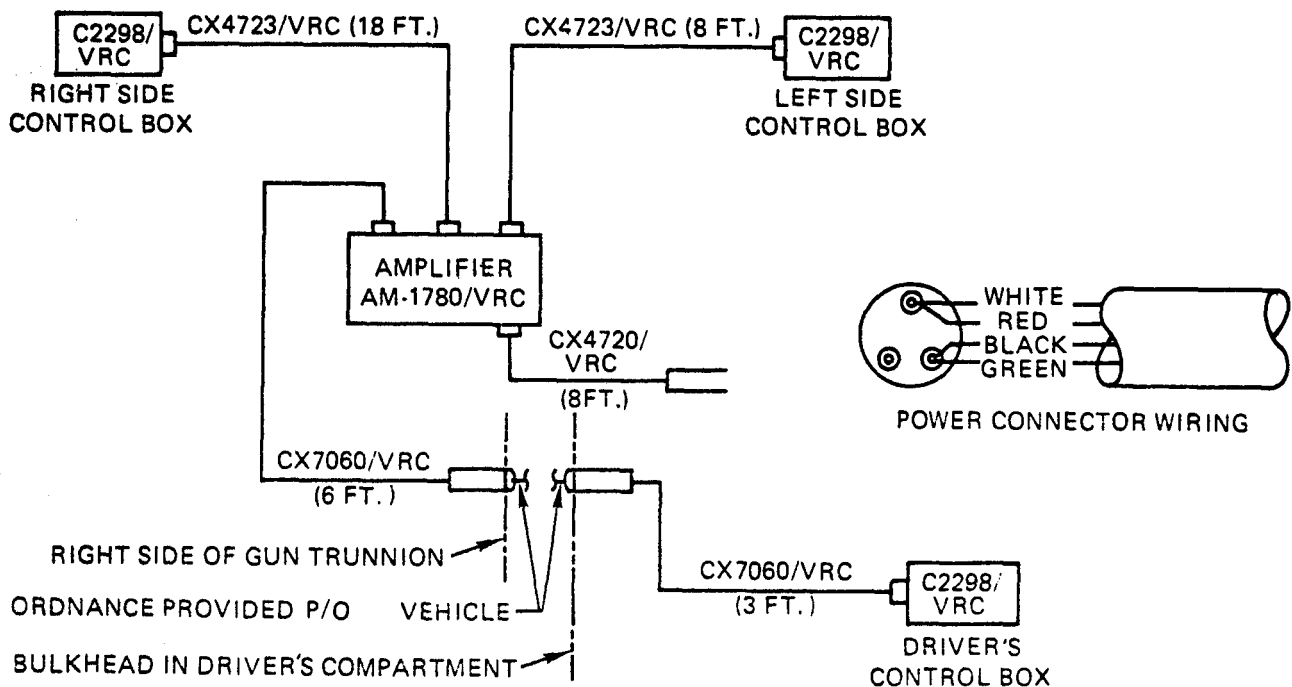

AN/VIC-1 in M107 and M110



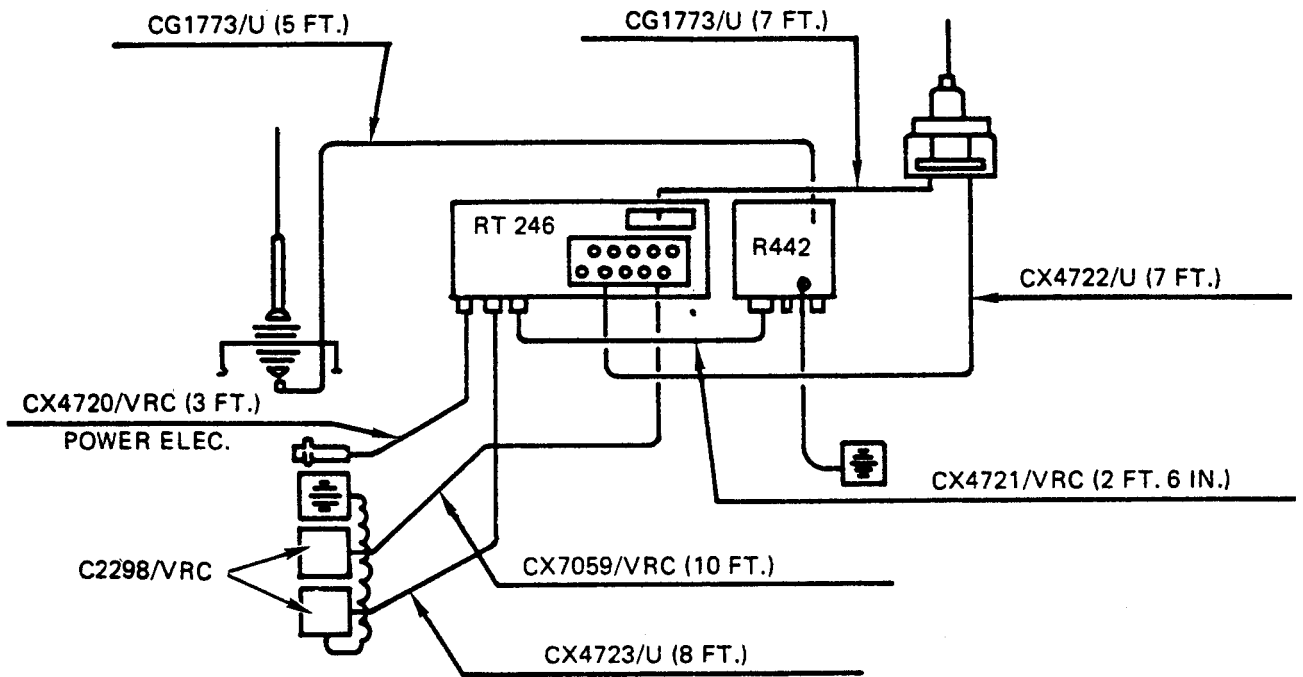

AN/VRC-12 in 1/4-ton Truck, M151A1

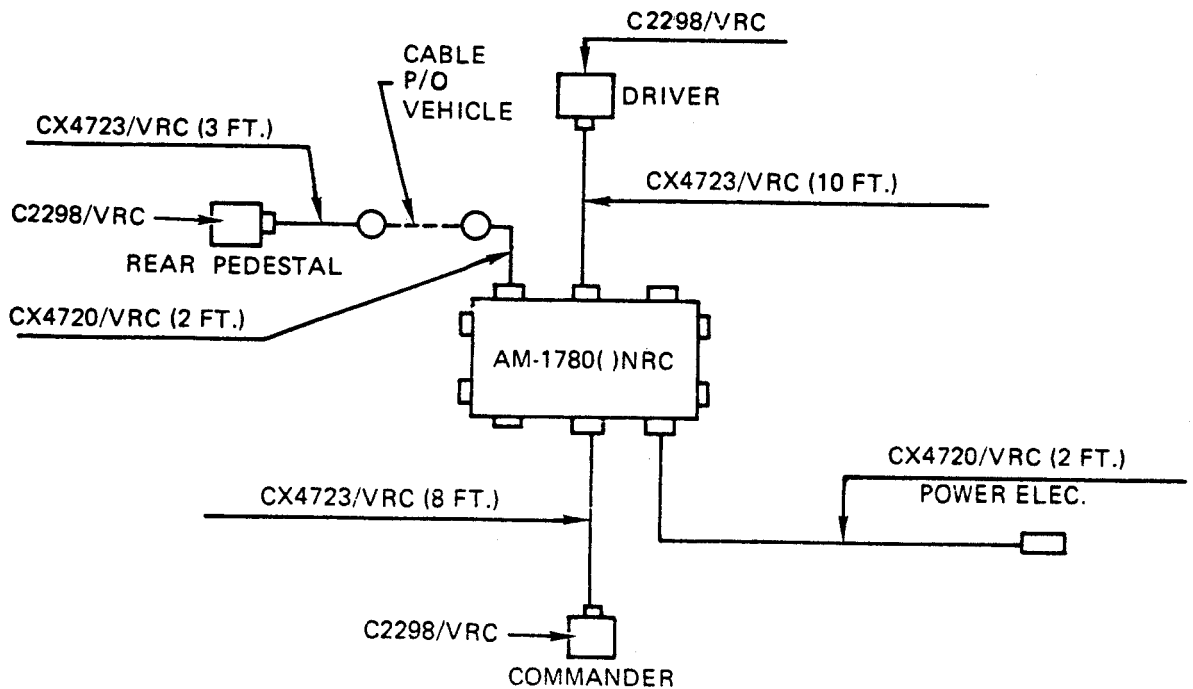

AN/VIC-1 in Mobile Floating Assault Bridge/Ferry

**TM 9-2350-275-BD  
COMMUNICATIONS SYSTEM**

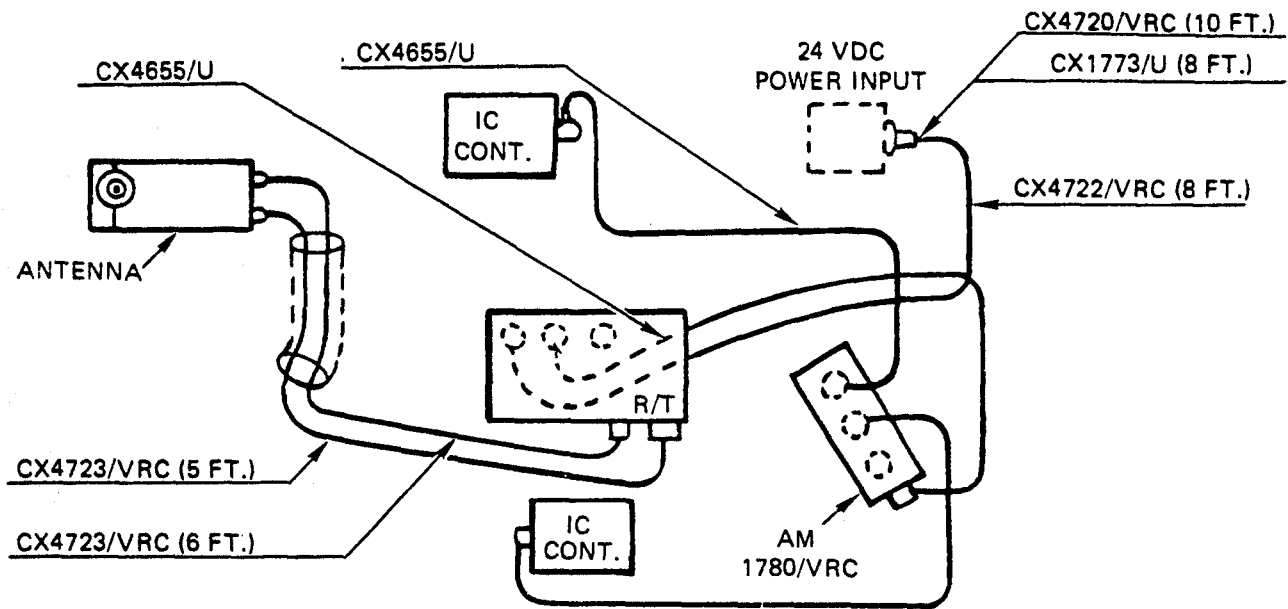

NOTE: THERE IS A 40 FT. AUDIO EXTENSION CABLE AND RF CABLE BETWEEN THE MX-6707 AND THE R/T.

**AN/VRC-12 and AN/VIC-1 in AVLB (M60 Chassis)**

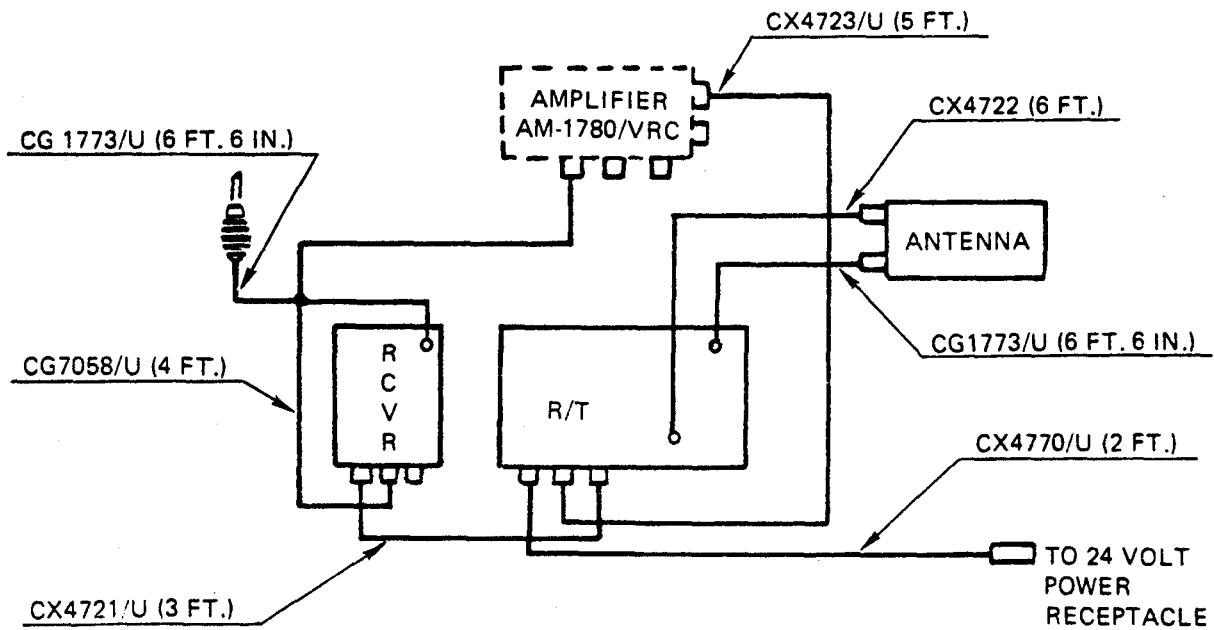

**AN/VRC-12 or AN/VRC-47 in M561**

**TM 9-2350-275-BD  
COMMUNICATIONS SYSTEM**

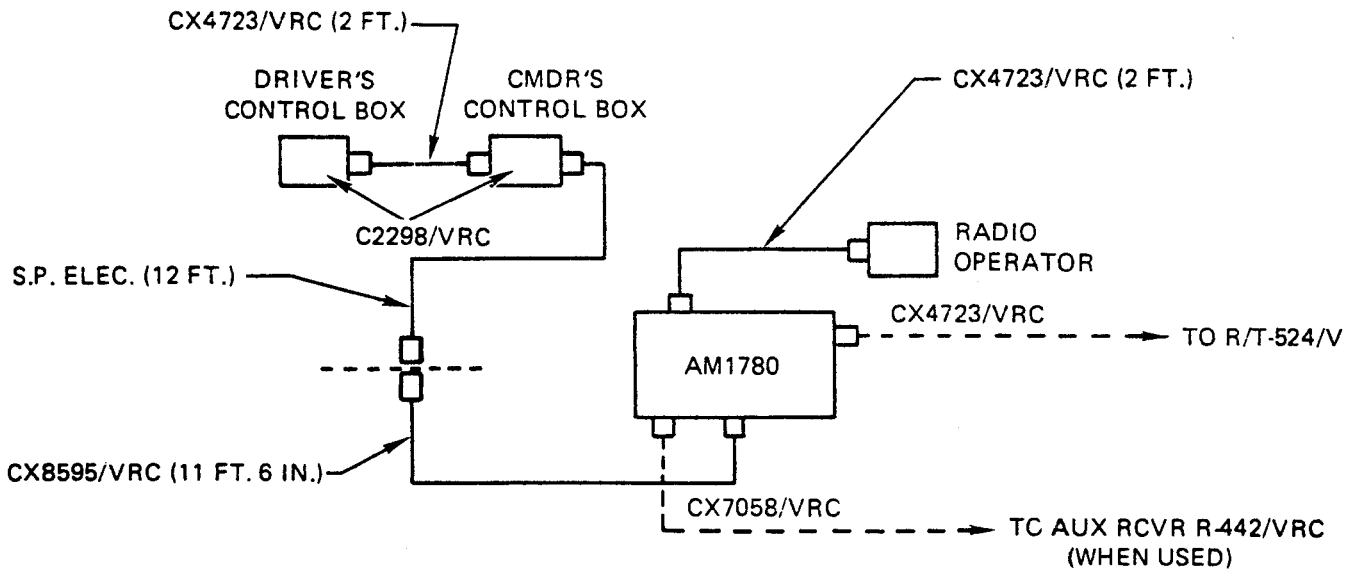

**AN/VIC-1 in M561 Commo Vehicle, Radio Sets in Rear**

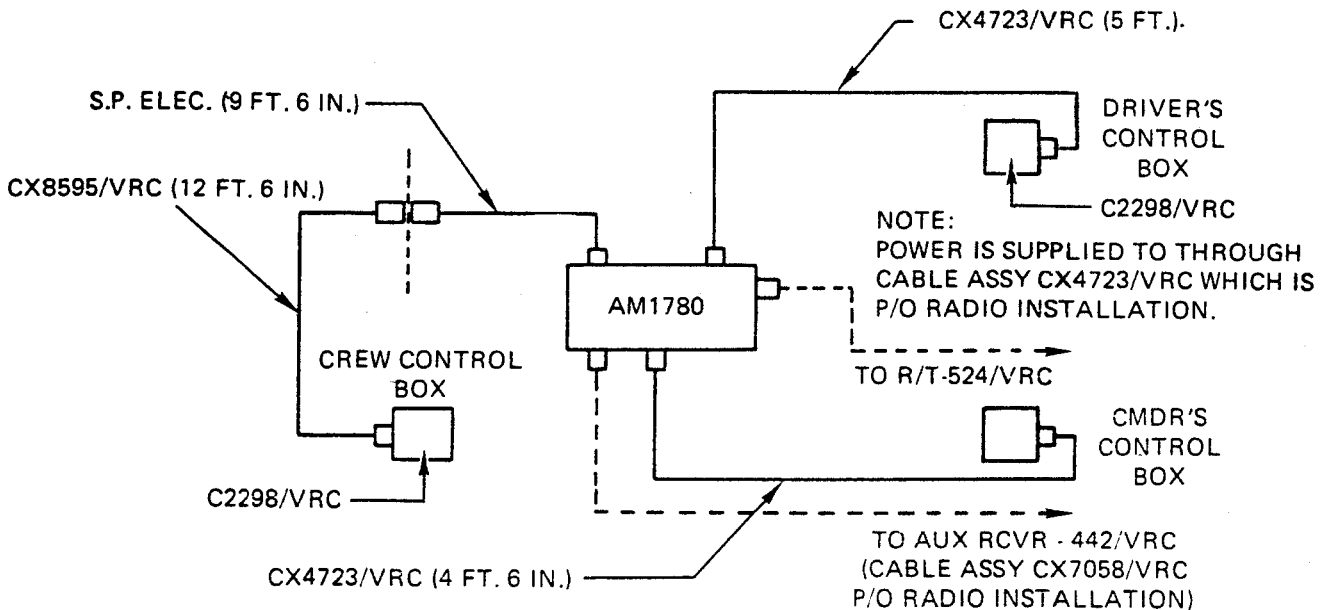

**AN/VIC-1 in M561 Commo Vehicle, Radio Sets in Cab**



APPENDIX A  
ALTERNATE SOURCES OF SUPPLY

BDAR FIXES SHALL BE USED ONLY IN COMBAT  
AT THE DISCRETION OF THE COMMANDER  
AND SHALL BE REPAIRED BY STANDARD MAINTENANCE PROCEDURES  
AS SOON AS PRACTICABLE AFTER THE MISSION IS COMPLETED.

**SECTION I. General.**

**A-1. General.**

This appendix lists alternate sources of supply to include foreign ownership of US combat vehicles and expendable supplies which may be utilized for repairs on this vehicle.

**SECTION II. Foreign Ownership of US Weapons Systems**

**A-2. General.**

Repair parts are expected to be in short supply. Parts may be available from other nations involved in the immediate combat areas. Friendly nations owning US weapons systems may have stocks of repair parts or equipment available for cannibalization. The following tables identify nations owning American combat vehicles.

Table A-1

North American and Europe

	Tank M60/M48 Family	M113 FOV	SOP. How M110	SOP. How M109	S.P. How M108	SOP. How M107	Lance
Austria	x			x			
Belgium		x	x	x	x		x
Britian			x			x	x
Canada		x		x			
Denmark		x		x			
Fed Rep Ger	x	x	x	x		x	x
Greece	x	x	x	x			x
Italy	x	x		x			x
Netherlands		x	x	x		x	x
Norway	x	x		x			
Portugal	x	x		x			
Spain	x	x	x	x	x	x	
Turkey	x	x	x				
Switzerland		x		x			

**Table A-2**

**Asia**

	Tank M60/M48 Family	M113 FOV	SOP. How M110	SOP. How M109	SOP. How M108	S.P. How M107	Lance
Japan			x				
New Zealand		x					
Pakistan	x	x		x			
Philippines		x					
Singapore		x					
South Korea	x	x	x	x		x	
Taiwan	x	x	x	x	x		
Thailand	x	x					
Viet Nam	x	x	x	x			



**Table A-3**  
**Africa and Middle East**

	Tank M60/M48 Family	M113 FOV	S.P. How M110	S.P. How M109	S.P. How M108	S.P. How M107	Lance
Egypt	x	x					
Ethopia		x		x			
Iran	x	x	x	x			
Israel	x	x		x		x	x
Jordan	x	x	x	x			
Kuwait		x					
Lebanon	x	x					
Libya		x		x			
Morocco	x	x		x			
North Yeman	x	x					
Oman	x						
Saudia Arabia	x	x	x				
Sudan	x	x					
Tunisia	x	x					
Zaire		x					

## **SECTION II. Expendable Supplies**

### **A-3. General.**

This appendix lists items recommended for the support of the M109 Howitzer in a combat environment. The lists include expendable supplies and materials which may be used to expedite BDAR repairs in a combat situation. The items listed may be required for Battlefield Damage Assessment and Repair at maintenance levels from crew through DS.

The column marked "Level" indicates the maintenance level at which it is recommended these items be stocked or carried. The unit commander may modify the items in the list and the maintenance levels carrying the items, based on current mission requirements and recent operational experience.

The items marked "C" (Crew) should be carried on the vehicle for use in combat emergencies at the discretion of the unit commander. Those items marked "MT" should be carried by each Battlefield Damage Assessment and Repair Maintenance Team (MT). Some of these items may already be available at organizational maintenance, however, additional items will be required to stock each MT. Those items marked "O" should be stocked at organizational level and those marked "MST" should be carried by the DS Maintenance Support Team (MST).

**EXPENDABLE SUPPLIES**

<b>ITEM NUMBER</b>	<b>LEVEL</b>	<b>NSN</b>	<b>DESCRIPTION</b>	<b>U/I</b>
1	0	8040-00-831-3403	Adhesive, epoxy 1 pt	kt
2	0	8040-00-828-7385	Adhesive/Sealant, silicone rubber, GE RTV 103	tu
3	0	8040-00-738-6429	Adhesive, epoxy	kt
4	MT	5999-00-661-0416	Cap, electrical: crimp style	pkg
5	c	8030-00-159-5032	Cement, epoxy, devcon F-2	kt
6	c	4730-00-289-5909	Clamp, hose: 3/8 in. to 1 in.	ea
7	c	4730-00-908-3193	Clamp, hose: 1 1/16 in. to 2 in.	ea
8	c	5350-00-192-5047	Cloth, abrasive: al-oxide 1/09 in. w, 11 in. lg (50 sheets)	pkg
9	MT	5315-00-598-5916	Cotter pin assortment	At
10	MT	5940-00-296-5326	Ferrule, electrical: wristlock type 22-14 wire size (10 in pkg)	pkg
11	o	5330-00-291-1605	Gasket, cork, 1/32 in.	sh
12	0	5330-00-171-9134	Gasket, cork, 3/16 in.	sh
13	c	5330-00-467-3615	Gasket, material, 1/32 in. (w.o.g. resistant)	sh
14	c	5330-00-223-5845	Gasket, material, 1/64 in. (w.o.g. resistant)	sh
15	o	5330-00-467-3615	Gasket, material, 1/32 in. (w.o.g. resistant)	sh

**TM 9-2350-275-BD  
APPENDIX A**

**EXPENDABLE SUPPLIES (Cont)**

<b>ITEM NUMBER</b>	<b>LEVEL</b>	<b>NSN</b>	<b>DESCRIPTION</b>	<b>U/I</b>
16	0	4720-00-623--9178	Hose, non-metallic, 1/4 in. ID	ft
17	0	4720-00-169-5112	Hose, non-metallic, 1/2 in. ID	ft
18	0	4720-00-288-9873	Hose, non-metallic, 3/4 in. ID	ft
19	0	8010-00-515-2487	Lacquer, insulating, electrical	pt
20	0	5310-00-297-3751	Nut Assortment	at
21	MT	5330-00-966-8657	Packing Assortment (O-rings)	ea
22	0	9650-00-264-5050	Pig Lead, 5 lb	lb
23	0	5410-00-7932021	Repair Kit, electronic equipment shelter (fiberglass)	ea
24	c	4020-00-968-1352	Rope, polypropylene (600 ft roll)	roll
25	MT	5320-01-004-0238	Rivet, pop, steel, SB4-2, 1/8 in. dia 1/8 in. lg (quantity 100)	hd
26	MT	5320-01-028-6621	Rivet, pop, steel, SB4-4, 1/4 in. dia 1/4 in. lg (quantity 50)	box
27	MT	5320-00-510-7823	Rivet, pop, aluminum, AB4-2A 1/8 in. dia 1/8 in. lg	ea
28	MT	5320-00-408-6073	Rivet, pop, aluminum, AB6-2A 3/16 in. dia 1/8 in. lg	hd
29	MT	8030-00-656-1426	Sealing Compound, gasket, non-hardening	pt
30	0	5335-00-054-5273	Screen Wire Mesh 60 in. x 150 ft	roll

**EXPENDABLE SUPPLIES (Cont)**

<b>ITEM NUMBER</b>	<b>LEVEL</b>	<b>NSN</b>	<b>DESCRIPTION</b>	<b>U/I</b>
31	0	8030-00-935-1083	Sealant, asphalt base, 8-lb	can
32	0	8030-00-965-2004	Sealant, synthetic rubber 1 pt	kt
33	0	8030-00-881-5238	Sealant and Puttying Compound Kit: kit no. 3 qt	kt
34	MT	5305-00-275-4073	SetScrew Assortment	at
35	MT	5940-00-840-0139	Splice, conductor: crimp style, wire size 10	ea
36	MT	5940-00-500-8723	Splice, conductor: crimp style, wire size 10	ea
37	c	5975-00-451-5001	Strap, tiedown (nlyon)	hd
38	MT	5820-00-783-9035	Strap, clamp, perforated	ft
39	c	9905-000-537-8957	Tag, blank, white	bd
40	c	8030-00-889-3535	Tape, anti-seizing pipe plug, teflon, 1/2 in. wide	ea
41	MT	5970-00-543-1005	Tape, electrical	roll
42	c	7510-00-802-8311	Tape, filament-reinforced: 3/4 in., 50 yd roll	roll
43	MT	5940-00813-0698	Terminal, lug: crimp style, stud sz 6, wire sz, 22-18	ea
44	MT	5940-00-577-3711	Terminal, lug: crimp style stud sz 10, wire sz 22-18	hd
45	MT	5940-00-283-5280	Terminal, lug: crimp style, stud sz 6, wire sz 16-14	ea
46	MT	5940-00-143-4780	Terminal, lug crimp style stud sz 10, wire sz 16-14	ea

EXPENDABLE SUPPLIES (Cont)

ITEM NUMBER	LEVEL	NSN	DESCRIPTION	U/I
47	MT	5940-00-1434794	Terminal, lug: crimp style, stud sz 10, unspec	ea
48	MT	5940-00-804-9185	Terminal, quick disconnect, wire sz 18	pkg
49	Mt	5940-00-804-9184	Terminal, quick disconnect, wire sz 14-16	pr
50	MT	5970--00-815-1295	Tubing, shrink, 1/4 in.	ft
51	MT	5970-00-812-2967	Tubing, shrink, 1 in.	ft
52	MT	5970-00-812-2968	Tubing, shrink, 1/6 in.	ft
53	MT	5970-00-812-2969	Tubing, shrink, 1/8 in.	ft
54	MT	5310-00-209-2312	Washer, lock, assortment	at
55	MT	5310-00-275-4290	Washer, flat; assortment	at
56	c	6145-00-152-6499	Wire, wire sz 14	ft
57	c	6145-00-435-8613	Wire, wire size 18	ft
58	MT	5315-00-271-4251	Woodruff Key Assortment	at

APPENDIX B  
SPECIAL AND FABRICATED TOOLS

BDAR FIXES SHALL BE USED ONLY IN COMBAT  
AT THE DISCRETION OF THE COMMANDER  
AND SHALL BE REPAIRED BY STANDARD MAINTENANCE PROCEDURES  
AS SOON AS PRACTICABLE AFTER THE MISSION IS COMPLETED.

**SECTION I. General**

**B-1. General.**

This appendix lists items recommended for the support of the vehicle in a combat environment. The items listed may be required for Battlefield Damage Assessment and Repair at maintenance levels from crew through DS. Also listed are expedient tools for performing BDAR repairs using non-standard equipment.

## **SECTION II. Tools**

### **B-2. General.**

Tools listed in this appendix will enhance crew members and mechanics at all levels to accomplish Battlefield Damage and Assessment repairs in a more expedient manner. Some tools listed may already be on hand in the unit.

The column marked "Level" indicates the maintenance level at which it is recommended these items be stocked or carried. The unit commander may modify the items in the list and the maintenance levels carrying the items, based on current mission requirements and recent operational experience.

The items marked "C" (Crew) are recommended to be carried on the vehicle for use in combat emergencies at the discretion of the unit commander. Those items marked "MT" are recommended to be carried by each Battlefield Damage Assessment and Repair Maintenance Team (MT). Some of these items may already be available at organizational maintenance, however, additional items will be required to stock each MT. Those items marked "O" are recommended to be stocked at organizational and those marked "MST" are recommended to be carried by the DS maintenance support teams (MST).



SECTION II. Tools

TOOLS

ITEM NUMBER	LEVEL	NSN	DESCRIPTION
1	C	5110-00-277-4591	Blade, hand hancsaw: 24 teeth per in., 10 in.
2	C	5110-00-927-1063	Blade, hacksaw, flat (tungsten)
3	MT	5120-00-203-6431	Clamp, C: 6 in. (2 required)
4	MT	5120-00-278-2423	Crimping Tool: terminal, hand w/cutting pin, stripper
5	MT	5120-00-278-6520	Cutter, tubing, close quarters
6	C	5120-00-227-8074	Extension, socket wrench: 1/2 in. sq dr 10 in. lg
7	C	5110-00-241-9153 5110-00-241-9156	File, hand: half rnd 10 in.
8	C	5110-00-234-6559	File, hand rnd style
9	C	5110-00-289-9657	Frame, hand hacksaw, 10 in. and 12 in. blade accommodated
10	o	4940-00-561-1002	Gun, thermal: PN8031088
11	C	5110-00-263-0349	Handle, file
12	C	5110-00-240-5943	Knife, pocket: w/clevis, screwdriver, wire scraper and cutting blade
13	C	5120-00-221-1536	Knife, putty
14	C		Lifter, roadwheel arm
15	C	5120-00-239-8251	Pliers: linemans w/side cutter, 8 in.
16	C	5120-00-247-5177	Pliers: lrnd nose w/cutter, 6 in.

**TOOLS - Continued**

ITEM NUMBER	LEVEL	NSN	DESCRIPTION
17	C	5120-00-278-0352	Pliers, slip joint: angle nose, multiple tongue and groove, 10 in.
18	C	5120-00-624-8065	Pliers, slip joint: conduit w/o hdl, w/removable plastic inserts, 9 in. lg
19	C	5120-00-293-0448	Punch, aligning: 3/16 in. pt, 8 in. lg, 3/8 in. dia
20	C	5120-00-595-9531	Punch, aligning: 1/4 in. pt, 12 in. lg
21	C	5120-00-242-5966	Punch, drive pin: 1/8 in.
22	O	4931-01-119-7103	Repair Kit, electrical connector: PN 12285360
23	MT	5120-00-017-2849	Riveter: blind, hand
24	C	5120-00-234-8913	Screwdriver, cross tip No. 2
25	C	5120-00-221-7063	Scriber, machinists: double point <u>Opening, In.</u>
26	C	5120-00-237-0982	Socket, socket wrench, 3/8 sq dr, 12 pt opening, regular length
27	C	5120-00-189-7924	Socket, socket wrench, 7/16 sq dr, 12 pt opening, regular length
28	C	5120-00-237-0984	Socket, socket wrench, 1/2 sq dr, 12 pt opening, regular length
29	C	5120-00-189-7932	Socket, socket wrench, 9/16 sq dr, 12 pt opening, regular length
30	C	5120-00-189-7946	Socket, socket wrench, 5/8 sq dr, 12 pt opening, regular length

**TOOLS - Continued**

ITEM NUMBER	LEVEL	NSN	DESCRIPTION
<u>Opening, In. - Continued</u>			
31	C	5120-00-235-5870	Socket, socket wrench, 11/16 sq dr, 12 pt opening, regular length
32	C	5120-00-189-7985	Socket, socket wrench, 3/4 sq dr, 12 pt opening, regular length
33	C	5120-00-189-7933	Socket, socket wrench, 13/16 sq dr, 12 pt opening, regular length
34	C	5120-00-189-7934	Socket, socket wrench, 7/8 sq dr, 12 pt opening, regular length
35	C	5120-00-189-7935	Socket, socket wrench, 15/16 sqdr, 12 pt opening, regular length
36	C	5120-00-189-7927	Socket, socket wrench, 1 sq dr, 12 pt opening, regular length
37	C	5120-00-242-3349	Socket, deepwell, 1/2 in. dr, 3/4 in.
38	MT	5110-00-803-6339	Splitting Tool, nut, 7/8 in. cap
39	MT	6625-01-102-6878	TA-1 Continuity and Test Probe Kit: PN 12303622
40	C	5140-00-498-8772	Tool Box, portable steel w/removable tray 21 in. lg, 8-1/2 in. w, 7-3/8 in. h
41	MT	5120-01-128-5511	Tool Set, supplement, organizational: PN 12310894
42	C		Web Strap Assembly, adjustable: PN 12273481
43	C	5120-01-121-4981	Wrench, plug, sraight bar hex: PN 12284998
44	C	5120-00-240-5328	Wrench, adjustable: 8 in.

**TM 9-2350-275-BD**  
**APPENDIX B**

TOOLS - Continued

ITEM NUMBER	LEVEL	NSN	DESCRIPTION
			<u>Opening, In. - Continued</u>
45	C	5120-00-277-4244	Wrench, plier: straight jaw, 8-1/2 in.
46	C	5120-00-148-7917	Wrench Set, combination box with open end, 12 components, 5/16 in. -1 in.
47	C	5120-00-148-7918	Wrench Set, open end, fixed, 6 components 3/16 in. - 1-1/ 16 in.

### SECTION III. Test Equipment

#### B-3. FIELD EXPEDIENT TEST EQUIPMENT

##### General Information:

Sometimes, in the process of assessing the battlefield damage, it is necessary to make voltage and resistance measurements to determine where the fault is. Standard test equipment (voltmeter, ohm meter, SWR meter, etc.) should be used whenever possible. If standard test equipment is not available, field expedient equipment can be fabricated using parts commonly found on the vehicle and in the forward maintenance areas. The following paragraph provides fabrication instructions for making a voltmeter, ohmmeter, and RF transmitter output tester.

##### NOTE

Accurate measurements are not available. These are Go - No-Go meters.

##### 1. Making a Voltmeter.

A voltmeter can be made from a light bulb and two pieces of wire. The pieces of wire can be connected to the case and center terminal of the bulb by means of solder, twisting, or simply holding the wire ends against the bulb (see illustration). The voltage rating of the bulb should be close to the value of the expected voltage being measured. For voltages in the 18 to 30 vdc range, any light bulb on the driver's master panel, driver's instrument panel, gunner's panel, commander's panel, or gunner's primary sight can be used. For voltages of 5 vdc or less a two-battery cell flashlight bulb can be used. The presence of voltage will cause the bulb to glow. Polarity of dc voltage does not have to be observed; even ac voltage can be measured. Twist exposed wire ends together and apply solder, if available, and solder. Touch to voltage source when ready to make measurement.

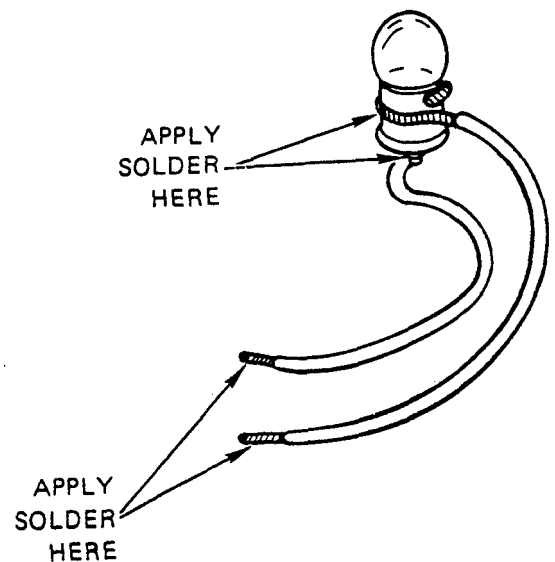

### FIELD EXPEDIENT TEST EQUIPMENT (CONT)

#### 2. Making an Ohmmeter (continuity tester).

An ohmmeter can be made from a flashlight bulb, flashlight battery, and three pieces of wire. When the free ends of the wires are touched to a circuit where continuity (or a short) exists, the bulb will glow. If a two-cell flashlight bulb is used with only one battery, the bulb will glow with one-half its normal brilliance.

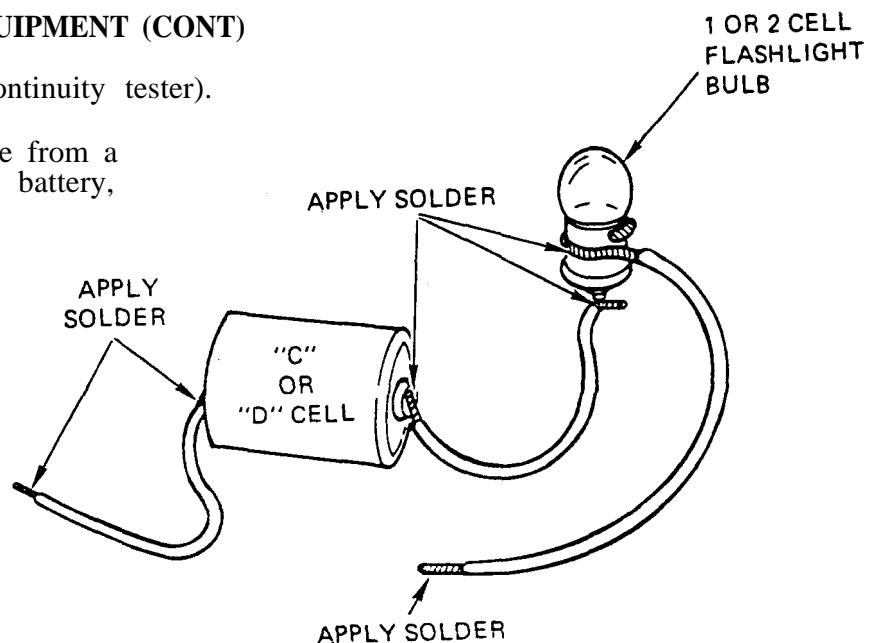

#### 3. Making an RF Transmitter Output Tester.

This device is used to determine if the radio is sending a signal to the antenna.

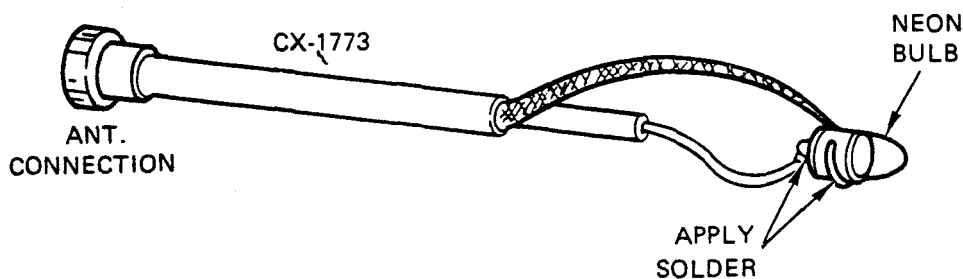

a. An RF transmitter output tester can be made from a neon light bulb and a piece of CG-1773 RF cable. Solder the bulb to the cable as shown in the illustration. Connect the cable to the ANT connection on the front of the radio. When the radio is keyed, the bulb will glow if RF power is present at the antenna connection (this does not verify transmitter frequency accuracy).

b. Another way to check for transmitter output is to hold a common (wood) lead pencil tip 1/4-inch to 1/8-inch from the ANT connection. If RF power is present, a yellowish-white arc will jump from the connector to the pencil tip when the radio is keyed.

## SECTION IV. Welding Expedients

### B-4. CONTROLLED AMPERAGE

#### General Information

Battlefield repairs requiring welding can be done by using the auxiliary generator (Little Joe) from the M88 or generator recovery vehicle if a regular welder is not available.

#### Limitations:

- Possible degraded armor protection

#### Materials/Tools:

- Auxiliary generator (24 vdc)
- Control unit from a welder or similar control
- Welders helmet and gloves
- Welding rod, coat hangers, or barbed wire
- Heavy gauge cable (2.0 gauge or larger)
- Vise grips or clamps
- Fuel line

#### Personnel/Time Required:

- 2 soldier
- 1-2 hours

#### Other Options

- Use uncontrolled amperage
- Weld using vehicle battery power

#### Procedural Steps:

1. Remove auxiliary generator from M88 recovery vehicle and place close to area to be welded. Connect heavy gauge cables to (+) and (-) output posts. Also connect control unit to (+) and (-) output posts. Tighten terminal securely.
2. Connect negative (-) cable to tank hull with clamp close to area to be welded. Connect welding rod to positive (+) cable with vise grips. Insulate vise grips with gloves, rags, or several layers of dry paper.

#### WARNING

Use welder's helmet to protect eyes and face from arc. Do not touch exposed cable or vise grips with bare hands; metal gets very hot. Do not perform this task in rain or on wet ground because of electrical shock hazard.

**TM 9-2350-275-BD**  
**APPENDIX B**

**Procedural Steps (Cont):**

3. Start auxiliary generator, strike arc, and weld. Set control unit for amperage level required by the thickness of the metal.
4. Record the BDAR action taken. When the mission is completed, as soon as practicable, repair vehicle using standard maintenance procedures.

**B-5. UNCONTROLLED AMPERAGE**

**General Information**

Battlefield repairs requiring welding can be accomplished by using auxiliary generator (Little Joe) from M88 recovery vehicle or a generator if a regular welder is not available. Welding will be difficult without amperage control.

**Limitations**

- Possible degraded armor protection

**Personnel/Time Required:**

- 2 soldiers
- 1-3 hours

**Materials/Tools:**

- Auxiliary generator (24 vDC)
- Heavy gauge cable (2.0 gauge minimum)
- Vise grips or clamps
- Fuel line
- Welder helmet and gloves
- Welding rod, coat hangers, or barbed wire

**Other Options:**

- Weld using the vehicle battery power

**Procedural Steps:**

1. Remove auxiliary generator from M88 recovery vehicle and place close to area to be welded. Connect heavy gauge cables (+) and (-) output posts and tighten securely.
2. Connect negative (-) cable to vehicle hull with clamp close to area to be welded. Connect welding rod to positive (+) cable with vise grip and insulate area against heat with gloves, rags, or several layers of dry paper.



**Procedural Steps (Cont):**

**WARNING**

Use welder's helmet to protect eyes and face from arc. Do not touch exposed cable or vise grips with bare hands; metal will get very hot. Do not perform this task in rain or on wet ground because of possible electric shock.

3. Start auxiliary generator, strike arc, and weld. Use small diameter welding rod for thin metal; use large welding rod for thick metal. Continue to weld until repair is satisfactory.
4. Record the BDAR action taken. When the mission is completed, as soon as practicable, repair vehicle using standard maintenance procedures.

**SECTION V. Containers**

**B-6. IMPROVISED CONTAINER**

**General Information**

Many repairs require the draining of the fluid systems (fuel, coolants, or oils). An improvised container can be used to catch the fluids.

**Limitations:**

- None

**Personnel/Time Required**

- 2 soldiers
- 20-30 minutes

**Materials/Tools**

- Large plastic sheet
- Poncho
- Tarpalin

**Procedural Steps:**

1. Dig a basin large enough to hold liquid.
2. Line the hole with a liner to hold the fluids.
3. Drive the vehicle over the hole.
4. Drain the liquid.
5. Dip the liquid from the hole using a steel helmet, can or canteen cup.
6. Record the BDAR action taken. When the mission is completed, as soon as practicable, repair the vehicle using standard maintenance procedures.



## APPENDIX C POL SUBSTITUTES

BDAR FIXES SHALL BE USED ONLY IN COMBAT  
AT THE DISCRETION OF THE COMMANDER  
AND SHALL BE REPAIRED BY STANDARD MAINTENANCE PROCEDURES  
AS SOON AS PRACTICABLE AFTER THE MISSION IS COMPLETED.

### SECTION I. General

#### C-1. General.

a. POL products available within the US and NATO military supply systems, commercial products and, captured products may be acceptable substitutes for POL shortages. Some POL will be destructive if used. This appendix provides tables on how to blend or mix good fuels with poor or non-fuels to increase the available quantity of fuel. This appendix also presents information on lubricants and hydraulic fluids. The tables divide POL products into three categories as follows:

Primary. The correct product for the system.

Alternate. A product that closely matches the primary but will result in reduced performance. Using the alternate POL will have no effect on the durability of the system. There are no restrictions on the duration of use.

Emergency or Expedient. A product that can be used for a short period of time only. These products are a last resort only and will result in a significant reduction in performance and in serious harm to the system with continued use.

b. POL products are usually identified by NSNs or part numbers which identify the product, however, specification numbers and product names may also be a means of identifying the product. Guidance provided is keyed to specification numbers, product names, application (automotive, aviation, marine), and the type of user (military, commercial and foreign).

c. NATO products can usually be assumed to be direct replacements for US Military products, but there are some products which do not meet the same user applications. The American Society of Testing and Measurements (ASTM) specifications relate to commercial products found in the US.

d. This section will list a few elementary characteristics of importance, although you will have no means of measuring or predicting them. You can use the basic fuels, as provided, in order or priority. It will tell you how to mix one or more fluids to produce a usable fuel and finally tell how to remove or flush a fuel from the system.

e. Table C-1 identifies fuels or products that can be used as fuels. One of the best means to increase the available fuel is to use potential substitutes as extenders by mixing them with the primary fuels and not using them as the sole fuel source. This allows some products which could not ordinarily be burned (or pumped) to be used by diluting them. Because of the dangers of varying combustibility of fuels, increased by vaporization during filling, the blending process is very important. The most direct and expedient procedure to mix fuels is to add the two fuels at the same time from two separate fuel lines. If added directly to the vehicle fuel tanks as separate fuels there is not sufficient turbulence in filling or shaking by normal driving to provide a properly mixed fuel. In vehicles with more than one tank, you could end up with a distinct fuel type in each tank.

## **C-2. FUEL BLENDING.**

a. In following the blending procedure it must be remembered that the basic fuel is the better of the two fuels and the extender is the poorer. The blending fuel is the extender. While you can use up to 50 percent (half and half) of the extender you should not use more than is needed to obtain the supply needed. Also, ensure a fuel tank or container is available to hold the quantity of fuel needed to perform the mixing operation.

b. Blending Procedure. The preferred location to accomplish blending is at a fuel dispensing site or in fuel dispensing vehicles that utilize their own pumps. The least desirable is using vehicle's fuel tanks. Blending in vehicle fuel tanks should only be done as a last resort because it is imprecise and time consuming.

(1) Blending in Fuel Dispensing Vehicles. Add the blending fuel to the fuel tank and mix by reconnecting the pump inlet hose to the vehicle and recirculating the fuel for a minimum of 15 minutes.

(2) Blending in 55 Gallon Drums. Add the blending fuel directly into a drum and mix by rolling the drum.

(3) Blending in Gravity Feed Tanks (Stationary) Not Equipped With Fuel Transfer Pumps. Blending fuel can be added manually or by using the pump and meter of a fuel dispensing vehicle. Add the blending fuel and mix by recirculating from the tank outlet to the tank truck pump inlet.

### **NOTE**

Blending in the fuel tanks of using equipment and vehicles should be undertaken only as a last resort. Add both fuels to the fuel tank at the same time with dual nozzles, or from fuel cans.

c. If expedient fuels are not used completely during the operation, they should be drained or pumped out. Fill the vehicle fuel tanks with 10-15 gallons of an approved primary fuel and run the engine for at least 1/2 hour. Operate the engine under a load or drive the vehicle a sufficient distance to bring the engine up to operating temperature.

### C-3. LUBRICANTS AND HYDRAULIC FLUIDS.

This section lists a few elementary characteristics of importance although there are no expedient means of measuring or predicting them. A list of basic fluids which can be used is provided in order of priority. Cautions on incompatible fluids are mentioned and a means suggested to flush the system.

b. Table C-2 provides a list of basic fluids which can be used as substitutes (alternate and expedient). It is structured around the vehicle lube order. Alternate products shown are NATO equivalents to the US specifications and can really be considered primary fluids. There are no corresponding ASTM designators. The expedients are emergency only substitutions. They may cause one of three problems either individually or in combination.

(1) They may not allow proper or efficient operations because of improper viscosity.

(2) They may cause high wear rate because of improper viscosity.

(3) They may cause seal damage or create deposits because of improper chemical composition.

c. There are no established time constraints on these expedients but the shorter the time used the better.

### C-4. FLUSHING LUBRICANT AND HYDRAULIC SYSTEMS.

a. Expedient lubricant and hydraulic fluids must be removed as soon as possible, and the system cleaned and inspected.

b. For those systems using oils, flushing involves draining, refilling with the proper product, operating to insure complete circulation and when possible stable operating temperature (this usually means at least 1/2 hour), a drain and refill. For the transmission and hydraulic system a second period of operations and a third drain and refill are needed. Installation of new filters is desirable. Filters must as a minimum be removed and cleaned. As a last resort only, operate without filters. While systems should not be disassembled to inspect seals, maintenance organizations should be prepared to replace seals that show signs of leaking. Organizations must observe seals on these systems during subsequent operations.

c. For systems using grease, it is normally necessary to disassemble the system and wash the parts, especially the bearings, in a suitable solvent. The parts are then wiped dry, inspected for wear and pitting, replaced if needed and repacked with the proper product.

Section II. Tables

TABLE C-1. FUELS AND SUBSTITUTE FUELS

(Listed in Order of Priority)

Primary Fuels

1. VV-F-800 (Diesel Fuels) (DF-1, DF-2, DF-A)
2. NATO-F-54 (Diesel Fuel, Military)
3. ASTM-D-975 (Automotive Diesel) (1-D & 2-D)
4. NATO-58 (Kerosene)
5. ASTM-D 3699 (Kerosene)
6. Any blend of the above.

Alternate Fuels

1. MIL-T-5624 (Aviation Turbine Fuel) (JP-4 & JP-5)\*
2. NATO-F-40 (Aviation Turbine Fuel)
3. ASTM-D- 1655 (Aviation Turbine Fuel) (Jet B)
4. NATO-F-44 (Aviation Turbine Fuel)
5. MIL-T-83133 (Aviation Turbine Fuel) (JP-4)
6. NATO-F-34 (Aviation Turbine Fuel)
7. ASTM-D- 1655 (Aviation Turbine) (Jet A-1 )
8. ASTM-D-2880 (Turbine Fuel) (O-CT, 1-GT, 2-GT, 3-GT, 4-GT)
9. MIL-F-16884 (Marine Diesel) (DFM)
10. NATO-F-76 (Navy Distillate Fuel)
11. MIL-F-815 (Navy Distillate) (FO-1 & FO-2)
12. NATO-F-75 (Navy Distillate) (Low Pour Point)
13. ASTM-D-396 (Fuel Oil) (No. 1 & 2)

With Fuel Extenders (Blends up to half and half -50 percent extender)

<u>Base</u>	<u>Extender</u>
14. Any Primary Fuel	Any Alternate Fuel
15. Any Alternate Fuel	Any Alternate Fuel
16. MIL-F-815	Any lighter primary or alternate
17. NATO-F-76	Any lighter primary or alternate
18. Any Diesel Fuel	PD-680 (Type I & II) (Dry Cleaning Solvent)
	ASTM-D-484 (K, I, II, III, IV) (D.C.S.)
	ASTM-D-235 (I thru IV) (Pet. Spirits)

\*Better than a 50 percent chance these will have acceptable Cetane.

TABLE C-1. FUELS AND SUBSTITUTE FUELS (Continued)

Expedient (Emergency) Fuel

Blends with other fuels or extenders (Note blend rates stated).

	<u>Base</u>	<u>Extender</u>
1.	Any Primary Fuel	Any Gasoline** - up to 50%
2.	Any Alternate Fuel	Any Gasoline II - up to 25%
3.	Any Primary Fuel	New engine oil - up to 50%
4.	Any Alternate Fuel	New engine oil - up to 75%
5.	Any Primary Fuel	Used engine oil
6.	Any Alternate Fuel	Used engine oil

Strained & filtered through charcoal or cloth. Any significant quantity of water must be removed.

**\*\*Gasolines**

1. MIL-G-3056 (Motor Gasoline) (Combat)
2. NATO-F-46 (Auto Gasoline) (91 RON) (Military)
3. NATO-F-49 (Auto Gasoline) (95 RON) (Military)
4. NATO-F-50 (Auto Gasoline) (91 RON)
5. VV-G-1690 (Auto Gasoline)
6. ASTM-D-439 (Auto Gasoline) (Any Grade)
7. MIL-G-53006 (Auto Gasoline)
8. MIL-G-5572 (Aviation Gasoline) (100/130)
9. NATO-F-18 (Aviation Gasoline) (100/130)
10. ASTM-D-910 (Aviation Gasoline) (100)
11. MIL-G-5572 (Aviation Gasoline) (115/145)
12. NATO-F-22 (Aviation Gasoline) (115/145)

C-2. SUBSTITUTE LUBRICANTS

C-6

TMM 9-2350-275-BD

Lubrication Point	Temp. Range	LO Authorized				Alternates			Incompatible or Ineffective Fluids	Notes
		LO Ref (Grd #)	Lube	US Specification	NATO Product	US Spec or Use Equiv NATO Prod	Soviet	Expedient		
Final Drive	Above 32°F +40°F to -10°F 0°F to -65°F	3	OE/HDO-30 OE/HDO-10 OEA	MIL-L-2104 MIL-L-2104 MIL-L-46167	0-238 0-238 0-183	Next grade of MIL-L-2104 or OEA				
Engine Oil	Above 32°F +40°F to -10°F 0°F to -65°F	3	OE/HDO-30 OE/HDO-10 OEA	MIL-L-2104 MIL-L-2104 MIL-L-46167	0-238 0-238 0-183	Next grade of MIL-L-2104 or OEA				
Transmission	Above 32°F +40°F to -10°F 0°F to -65°F	4	OE/HDO-10 OE/HDO-10 OEA	MIL-L-2104 MIL-L-2104 MIL-L-46167	0-238 0-238 0-183	Next grade of MIL-L-2104 or OEA				
Steering Control Lever	All	4	GAA	MIL-G-10924	G-403	MIL-L-2105	See Above			
Pivot Steer Master Cylinder	All	4	OHA	MIL-H-5606	H-515	MIL-H-6083 MIL-H-46170				
Mortar Socket (M106 only)	All	5	GAA	MIL-G-10924	G-403					
Rampwire Rope	Above 32°F +40°F to -10°F 0°F to -65°F	5	OE/HDO-30 OE/HDO-10 OEA	MIL-L-2104 MIL-L-2104 MIL-L-46167	0-238 0-238	VV-L-800				
Machine Gun Mount	Above 32°F +40°F to -10°F, 0°F to -65°F	1	PL-M PL-S PL-S	MIL-L-3150 VV-L-800 VV-L-800	0-198 0-190 0-190			Engine oils Hydraulic Fluids		
Fan Gear Box	Above 32°F +40°F to -10°F, 0°F to to -65°F	1	OE/HDO-30 OE/HDO-10 OEA	MIL-L-2104 MIL-L-2104 MIL-L-46167	0-238 0-238 0-183	Any Hydraulic Oil	M8GI, M109I, M-8V, M10V, M-8A, M-10A AS-9, AS-10, AS-11	Commercial Heavy Transmission	Below 0°F Soviet Products M6V, M6A, AS-3, AS-4, AS-5, AS-6	
Bi Pod Assembly (M125 only)	Above 32°F +40°F to -10°F, 0°F to -65°F	1	PL-M PL-S PL-S	MIL-L-3150 VV-L-800 VV-L-800	0-198 0-190 0-190			Engine oils Hydraulic Fluids		



C-2. SUBSTITUTE LUBRICANTS (CONT.)

Lubrication Point	Temp. Range	LO Authorized				Alternates			Incompatible or Ineffective Fluids	Notes
		LO Ref (Grd #)	Lube	US Specification	NATO Product	US Spec or Use Equiv NATO Prod	Soviet	Expedient		
Idler Wheel Support Arm Bearings	All	1	GAA	MIL-G-10924	G-403	*MIL-L-2105	TSIATIM-201 TSIATIM-221 UNIINP-232	Any vegetable or animal fat (Peanut Butter, etc.)		*Remove fitting, pour in, replace fitting.
Roadwheel and Idler Wheel Bearings	Above 32°F +40°F to -10°F 0°F to -65°F	1	OE/HDO-10 OE/HDO-10 OEA	MIL-L-2104 MIL-L-2104 MIL-L-46167	0-238 0-238 0-183	MIL-L-2105		Any Hydraulic Oil		
New Design	All		GAA	MIL-G-1092	G-403	*MIL-L-2105	See Above	Vegetable or animal fat (Peanut Butter, Butter, etc.)		*Remove fitting, pour in, replace fitting.
Roadwheel Support Arm Bearings	Above 32°F +40°F to -10°F 0°F to -56°F	1	OE/HDO-10 OE/HDO-10 OEA	MIL-L-2104 MIL-L-2104 MIL-L-46167	0-238 0-238 0-183	MIL-L-2105		Any Hydraulic Oil		
New Design	All		GAA	MIL-G-10924	G-403	*MIL-L-2105	See Above	Vegetable or animal fat (Peanut Butter, Butter, etc.)		*Remove fitting, pour in, replace fitting.
Universal Joint	All	2	GAA	MIL-G-10924	G-403		See Above			
Tachometer & All Speedometer		2	GIA	MIL-G-12827						
Differential	Above 32°F +40°F to -10°F 0°F to -65°F	2	OE/HDO-30 OE/HDO-10 OEA	MIL-L-2104 MIL-L-2104 MIL-L-46167	0-238 0-238 0-183	Next grade of MIL-L-2104 or OEA				
Transfer Case	Above 32°F +40°F to -10°F 0°F to -65°F	3	OE/HDO-30 OE/HDO-10 OEA	MIL-L-2104 MIL-L-2104 MIL-L-46167	0-238 0-238 0-183	Next grade of MIL-L-2104 or OEA				
Mortar Turn Table Gear (M106 & M105)	All	5	GAA	MIL-G-10924	G-403	MIL-L-2105	See Above	Vegetable or animal fat		
Hydraulic Tank (Ramp System)	All	5	OHA	MIL-H-5606	H-515	MIL-H-6083 MIL-H-46170				



## APPENDIX D

Not Used



## APPENDIX E

### BDAR FIXES AUTHORIZED FOR TRAINING

**BDAR TRAINING FIXES SHALL BE  
USED ONLY AT THE DISCRETION OF THE COMMANDER.  
DAMAGES SHALL BE REPAIRED BY STANDARD MAINTENANCE  
PROCEDURES AS SOON AS PRACTICABLE.**

<u>REPAIR PROCEDURE</u>	<u>PARAGRAPH NO.</u>
GENERAL AUTOMOTIVE COMPONENTS REFER TO TM 9-2350-276-BD)	
Gaskets, Leaking . . . . .	3-5
Gaskets, Engine . . . . .	3-6
Gasket, Environmental . . . . .	3-6
V-Belt-Missing or Broken . . . . .	3-9
Engine Transmission Housing Damage . . . . .	3-11
Bracket Broken . . . . .	3-13
Forcing Mismatched Threading . . . . .	3-15
Thread Clean-up . . . . .	3-16
Hardware Mounting . . . . .	3-17
Gearshift Lever Broken . . . . .	3-18
Push/PullRod Damaged . . . . .	3-19
Pulley Damaged . . . . .	3-20
Cable, Mechanical, Broken . . . . .	3-21
Pin-Alignment, Clevis, Cotter, Dowels, Quick, Release, etc. . . . .	3-22
COOLING SYSTEM	
V-Belt Missing or Broken . . . . .	5-7

**BDAR FIXES AUTHORIZED FOR TRAINING (CONT'D)**

<u>REPAIR PROCEDURE</u>	<u>PARAGRAPH NO.</u>
TRACK AND SUSPENSION	
Track Partially Thrown . . . . .	8-4
Short-Tracking, Idler Assembly Damaged . . . . .	8-5
Roadwheel/Hub Damaged . . . . .	8-7

U.S. GOVERNMENT PRINTING OFFICE: 1990 543-016/40015

INDEX

	Paragraph, Table Number
Air Cleaner Damaged.....	3-6
Alternate Sources Of Supply, General.....	A-1
Armor	
Assessment Procedure .....	10-2
BDAR Procedure Index.....	10-3
General .....	10-1
Assessing Battlefield Damage	
Application .....	2-3
Assessment Process .....	2-5
General .....	2-2, 2-4
Overall Vehicle Assessment.....	2-6
Scope.....	2-1
BDAR Forms, General.....	2-8
BDAR Introduction	
Application.....	1-3
Definitions .....	1-4
Purpose .....	1-1
Recommendations And QDR/EIR.....	1-5
Scope.....	1-2
BDAR Procedure Index	
Alphabetical .....	2-7
Armor .....	10-3
Communications .....	11-16
Cooling System.....	5-3
Electrical System.....	6-3
Engine .....	3-3
Fuel Supply System.....	4-3
Hydraulic System.....	9-3
Powertrain/Steering .....	7-3
Track And Suspension .....	8-3
BDAR Standards and Practices	
Characteristics .....	1-6
Training .....	1-7
Environment .....	1-9
Waiver Of Precautions.....	1-8
Operating Characteristics.....	1-10
Permanent Repair .....	1-11

**TM 9-2350-275-BD**  
**INDEX**

Paragraph,  
Table Number

BDAR Responsibilities And Tasks  
    General ..... 1-12  
    Commander And Crew ..... 1-13  
    Organizational Maintenance And Maintenance Teams (MT) . . . . . 1-14  
    Direct Support/General Support Maintenance Team . . . . . 1-15  
    Time Limits ..... 1-16  
    Recording Repairs ..... 7-17  
Brake Linkage Damaged ..... 7-7

Cables Are Too Short, BDAR Installation ..... 11-31  
Coaxial Cable Repair ..... 11-29  
Common Vehicle Cording Diagrams ..... 11-36  
Communications System  
    Functional Details ..... 11-3  
    General ..... 11-2  
    General Operating Instructions ..... 11-4  
    Scope ..... 11-1  
Connecting Rod Or Rod Bearing Failure ..... 3-17  
Coolant Frozen ..... 5-6  
Cooling System  
    Assessment Procedure ..... 5-2  
    BDAR Procedure Index ..... 5-3  
    General ..... 5-1  
Cooling System BDAR, General ..... 5-4

Drive Sprocket Or Hub Bolts Sheared ..... 8-6

Electrical BDAR, General ..... 6-4  
Electrical System  
    Assessment Procedure ..... 6-2  
    BDAR Procedure ..... 6-3  
    General ..... 6-1

Engine  
    Assessment Procedure ..... 3-2  
    BDAR Procedure Index ..... 3-3  
    General ..... 3-1

Engine Air Intake System, General ..... 3-5  
Engine Exhaust System, General ..... 3-7  
Engine Lubrication System, General ..... 3-8  
Engine Fuel System, General ..... 3-12  
Engine Malfunctions ..... 3-4  
Engine/Transmission Housing Damage ..... 3-16  
Expendable Supplies, General ..... A-3



Paragraph,  
Table Number

Fiberglass Whip Antenna Replacement .....	11-20
Field Expedient Radio Remote .....	11-34
Field Expedient Radio Mount Repair .....	11-24
Field Safety Switch Defective .....	6-7
Foreign Equipment Interchangeability (AN/VRC-12 Series) .....	11-25
Foreign Equipment Interchangeability (Allied Radios) .....	11-27
Foreign Equipment Interchangeability (Soviet Intercom R-124 ) .....	11-28
Foreign Equipment Interchangeability (Soviet Radio R-123M) .....	11-26
Foreign Ownership Of US Weapons Systems .....	A-2
Fuel Injector Line Rupture .....	4-5
Fuel Pump Interchangeability .....	4-6
Fuel Supply System	
Assessment Procedure.....	4-2
BDAR Procedure Index .....	4-3
General .....	4-1
Fuel Storage Systems, General .....	4-4
Gearshift Linkage Broken.....	7-4
General Interchangeability Information (Radio Components) .....	11-35
Ground Plane Antenna, Field Expedient.....	11-21
Hydraulic Configurations, General.....	9-4
Hydraulic Systems	
Assessment Procedures.....	9-2
BDAR Procedure Index.....	9-3
General .....	9-1
Improvised Armor, General.....	10-4
Improvised Container .....	B-16
Injector Failure.....	3-13
Intercom Cable Repair .....	11-30
Intercom System, Field Expedient .....	11-22
Intercommunications	
Does Not Work On Any Control Box .....	11-6
Works On Some Controll Boxes But Not All .....	11-7
Not Working Properly .....	11-8
Isolation Of Non-Essential Systems (General).....	11-32
Isolation Of Non-Essential Systems (Voltage Suppressors) .....	11-33
Metal Tube Damaged.....	5-5
Metallic Whip Antenna Broken .....	11-17
Metallic Whip Antenna Replacement.....	11-18
Metallic Whip Antenna Replacement; Long Wire Antenna .....	11-19

**TM 9-2350-275-BD**  
**INDEX**

Paragraph,  
Table Number

Neutral Safety Switch Defective.....	6-6
Oil Level Low.....	3-10
Oil Pan Holes.....	3-11
Oil Pump Failure.....	3-9
Piston, Engine, Perforated Head.....	3-15
POL	
Fuel Blending.....	C-2
Flushing Systems.....	C-4
General.....	C-1
Lubricants And Hydraulic Fluids.....	C-3
Powertrain/Steering	
Assessment Procedure.....	7-2
BDAR Procedure Index.....	7-3
General.....	7-1
Radio Assessment	
Aux Receiver Is Not Operating Properly.....	11-12
Distant Station Does Not Answer Radio Calls.....	11-10
Does Not Receive The Distant Station.....	11-9
Does Not Work In “New Squelch On”.....	11-11
Radio System, Field Expedient.....	11-23
Roadwheel Arm Damaged.....	8-9
Roadwheel Arm Housing Sheared.....	8-8
Roadwheel/Hub Damaged.....	8-7
Short-Tracking, Idler Assembly Damaged.....	8-5
Special And Fabricated Tools, General.....	B-1
Speech Security System Assessment	
Does Not Have Power.....	11-13
Usable To Communicate.....	11-14
Starter Failure.....	6-5
Steering System, General.....	7-6
Substitute Fuels.....	TC-1
Substitute Lubricants.....	TC-2
Suspension Component Interchangeability.....	8-10
Test Equipment, Expedient.....	B-3
Trottle Linkage Damaged.....	3-14

Paragraph,  
Table Number

Track And Suspension	
Assessment Procedure .....	8-2
BDAR Procedure Index.....	8-3
General.....	8-1
Track, Partially Thrown .....	8-4
Transfer Assembly Interchangeability .....	7-5
Tools, General.....	B-2
V-Belt, Missing Or Broken .....	5-7
Welding Expedients	
Controlled Amperage .....	B-4
Uncontrolled Amperage .....	B-5

By Order of the Secretary of the Army:

Official:

**JOHN A. WICKHAM, JR.**  
***General, United States Army***  
***Chief of Staff***

**ROBERT M. JOYCE**  
***Major General, United States Army***  
***The Adjutant General***

Distribution:

To be distributed in accordance with DA Form 12-32, Organizational Maintenance requirements for Lance Missile System and DA Form 12-37, Organizational Maintenance requirements for Carriers, Cargo, M548; Personnel, MI 13; Command Post, M577; Mortar, MI 06; Flame Thrower, MI 32; Recovery Vehicle, XM806; Personnel MI13A1; Command Post, M577A1; Mortar, M106A1; Mortar, M125A1; Flame Thrower M132A1; Gun, XM741; Recovery Vehicle, XM806E1 and Improved Tow Vehicle (ITV) and M901A1.

RECOMMENDED CHANGES TO EQUIPMENT TECHNICAL PUBLICATIONS



THEN... JOT DOWN THE DOPE ABOUT IT ON THIS FORM. CAREFULLY TEAR IT OUT. FOLD IT AND DROP IT IN THE MAIL!

**SOMETHING WRONG WITH THIS PUBLICATION?**

FROM: (PRINT YOUR UNIT'S COMPLETE ADDRESS)

DATE SENT

PUBLICATION NUMBER

TM 9-2350-275-BD

PUBLICATION DATE

9 Feb 84

PUBLICATION TITLE Battlefield Damage Assessment and Repair for M113 Family of Vehicles

BE EXACT... PIN-POINT WHERE IT IS

PAGE NO

PARA-GRAPH

FIGURE NO

TABLE NO

IN THIS SPACE TELL WHAT IS WRONG AND WHAT SHOULD BE DONE ABOUT IT:

PRINTED NAME, GRADE OR TITLE, AND TELEPHONE NUMBER

SIGN HERE

FILL IN YOUR  
UNIT'S ADDRESS

FOLD BACK

DEPARTMENT OF THE ARMY

POSTAGE AND FEES PAID  
DEPARTMENT OF THE ARMY  
DOD 314



OFFICIAL BUSINESS  
PENALTY FOR PRIVATE USE \$300

Commander:  
U.S. Army Tank Automotive Command  
Attn: DRSTA-MB-BDAR  
Warren, Michigan 48090

TEAR ALONG PERFORATED LINE

# THE METRIC SYSTEM AND EQUIVALENTS

## WEIGHT MEASURE

1 Centimeter = 10 Millimeters = 0.01 Meters = 0.3937 Inches  
 1 Meter = 100 Centimeters = 1000 Millimeters = 39.37 Inches  
 1 Kilometer = 1000 Meters = 0.621 Miles

## WEIGHTS

1 Gram = 0.001 Kilograms = 1000 Milligrams = 0.035 Ounces  
 1 Kilogram = 1000 Grams = 2.2 lb.  
 1 Metric Ton = 1000 Kilograms = 1 Megagram = 1.1 Short Tons

## LIQUID MEASURE

1 Milliliter = 0.001 Liters = 0.0338 Fluid Ounces  
 1 Liter = 1000 Milliliters = 33.82 Fluid Ounces

## SQUARE MEASURE

1 Sq. Centimeter = 100 Sq. Millimeters = 0.155 Sq. Inches  
 1 Sq. Meter = 10,000 Sq. Centimeters = 10.76 Sq. Feet  
 1 Sq. Kilometer = 1,000,000 Sq. Meters = 0.386 Sq. Miles

## CUBIC MEASURE

1 Cu. Centimeter = 1000 Cu. Millimeters = 0.06 Cu. Inches  
 1 Cu. Meter = 1,000,000 Cu. Centimeters = 35.31 Cu. Feet

## TEMPERATURE

$5/9(^{\circ}\text{F} - 32) = ^{\circ}\text{C}$   
 212° Fahrenheit is equivalent to 100° Celsius  
 90° Fahrenheit is equivalent to 32.2° Celsius  
 32° Fahrenheit is equivalent to 0° Celsius  
 $9/5^{\circ}\text{C} + 32 = ^{\circ}\text{F}$

## APPROXIMATE CONVERSION FACTORS

TO CHANGE	TO	MULTIPLY BY
Inches	Centimeters	2.540
Feet	Meters	0.305
Yards	Meters	0.914
Miles	Kilometers	1.609
Square Inches	Square Centimeters	6.451
Square Feet	Square Meters	0.093
Square Yards	Square Meters	0.836
Square Miles	Square Kilometers	2.590
Acres	Square Hectometers	0.405
Cubic Feet	Cubic Meters	0.028
Cubic Yards	Cubic Meters	0.765
Fluid Ounces	Milliliters	29.573
its	Liters	0.473
arts	Liters	0.946
allons	Liters	3.785
Ounces	Grams	28.349
Pounds	Kilograms	0.454
Short Tons	Metric Tons	0.907
Pound-Feet	Newton-Meters	1.356
Pounds per Square Inch	Kilopascals	6.895
Miles per Gallon	Kilometers per Liter	0.425
Miles per Hour	Kilometers per Hour	1.609

TO CHANGE	TO	MULTIPLY BY
Centimeters	Inches	0.394
Meters	Feet	3.280
Meters	Yards	1.094
Kilometers	Miles	0.621
Square Centimeters	Square Inches	0.155
Square Meters	Square Feet	10.764
Square Meters	Square Yards	1.196
Square Kilometers	Square Miles	0.386
Square Hectometers	Acres	2.471
Cubic Meters	Cubic Feet	35.315
Cubic Meters	Cubic Yards	1.308
Milliliters	Fluid Ounces	0.034
Liters	Pints	2.113
Liters	Quarts	1.057
ers	Gallons	0.264
ms	Ounces	0.035
ograms	Pounds	2.205
Metric Tons	Short Tons	1.102
Newton-Meters	Pounds-Feet	0.738
Kilopascals	Pounds per Square Inch	0.145
ometers per Liter	Miles per Gallon	2.354
ometers per Hour	Miles per Hour	0.621

